

GROUP 15

**INTAKE AND
EXHAUST**

CONTENTS

AIR INTAKE SYSTEM	15-2	EXHAUST SYSTEM	15-5
AIR DUCT AND AIR CLEANER	15-2	TURBOCHARGER	15-5
CHARGE AIR COOLER	15-2	EXHAUST PIPE AND MUFFLER	15-6
CHARGE AIR COOLER WATER SPRAY .	15-3		

AIR INTAKE SYSTEM

AIR DUCT AND AIR CLEANER

M2150004000032

- Unrestricted fresh ambient air enters from above the radiator, engine performance has been enhanced and intake air noise has been reduced.
- The air cleaner is made from recycled paper mixed with plastic to reduce industrial wastes and protect the environment.
- Environmentally-friendly unleaded rubber materials are used for the air intake hose.

CONSTRUCTION DIAGRAM

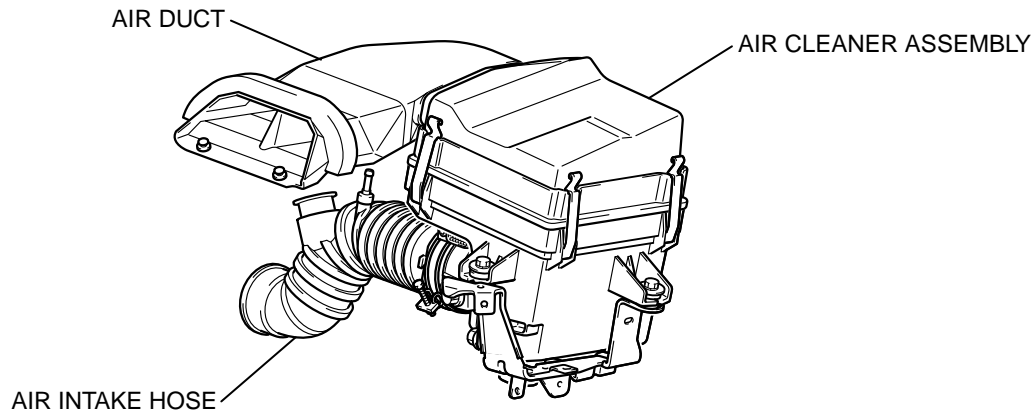

AC210029 AB

CHARGE AIR COOLER

By mounting an air cooled charge air cooler to reduce the intake air temperature after boosting, engine output has been improved.

M2150007000019

CONSTRUCTION DIAGRAM

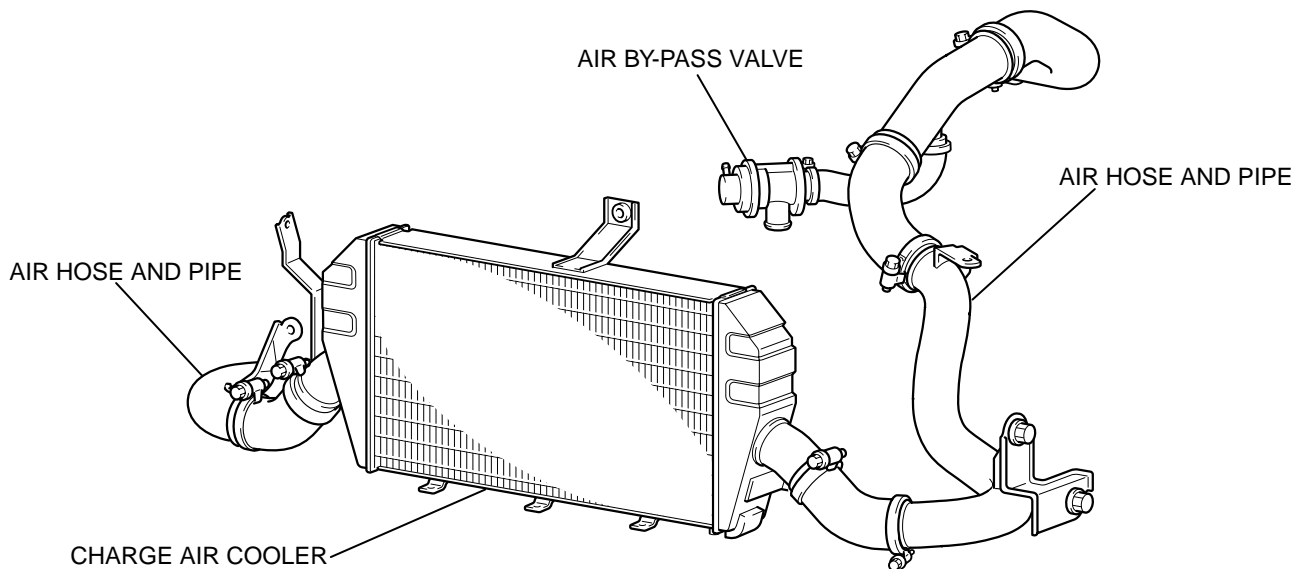

AC210030 AB

CHARGE AIR COOLER WATER SPRAY

M2150008000012

To complement the charge air cooler efficiency in ranges where the cooling efficiency of the air cooled charge air cooler is insufficient, and attain high performance in various environments, the system cools by spraying water from a special washer tank for the charge air cooler to the front of the charge air cooler. Features of the charge air cooler water spray system are:

- Sprays water when the water spray switch on the floor console is operated.
- Enables switching between the driver-operated manual mode and the auto mode, which automatically sprays water at the optimum operating conditions by signals from the engine control module (ECM) according to the engine state.
- Two water spray nozzles are located at optimum positions to enhance the charge air cooler efficiency.

CONSTRUCTION DIAGRAM

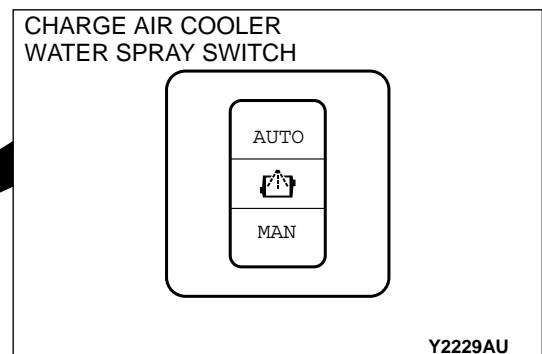
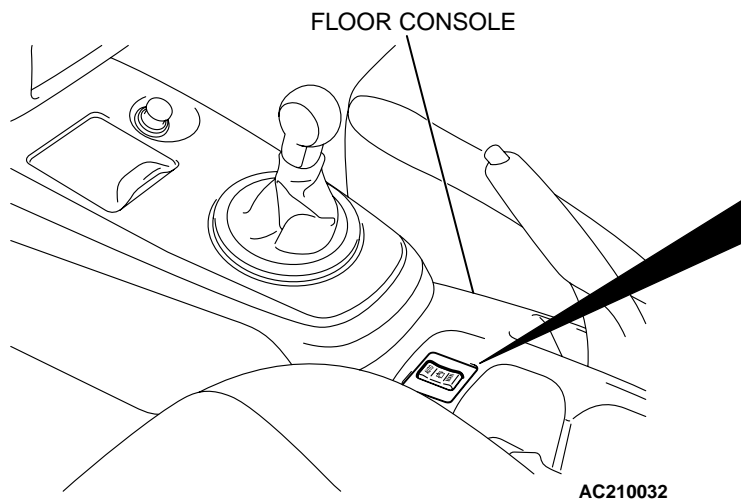
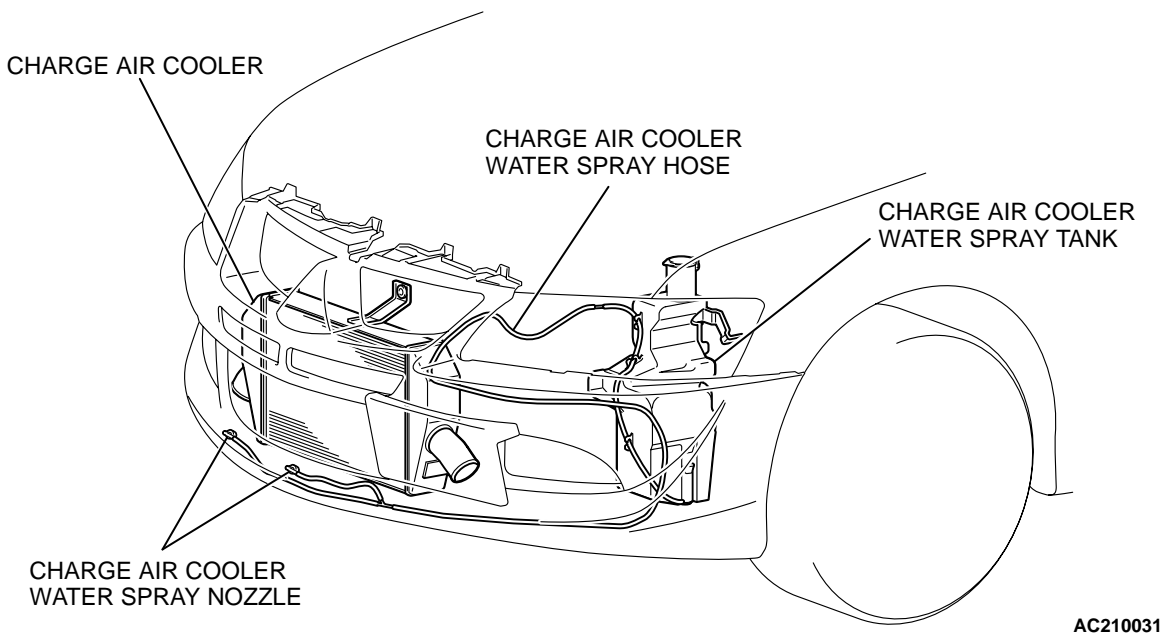

SYSTEM DIAGRAM

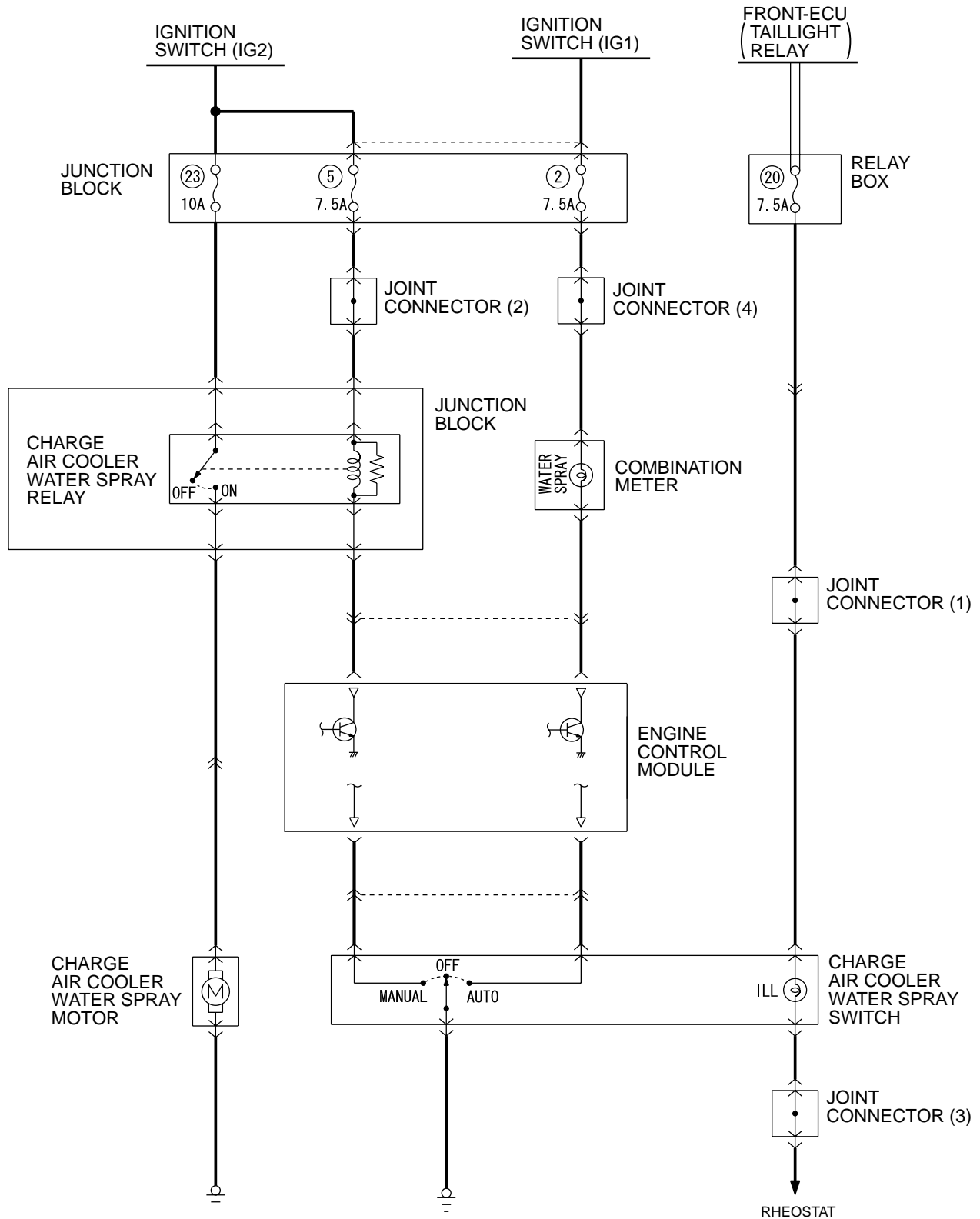

EXHAUST SYSTEM

TURBOCHARGER

M2150009000015

Dual exhaust passages from the engine to the turbine housing prevents obstruction of the flow and guides the exhaust gas smoothly to the turbine to improve low and mid-range torque and engine response.

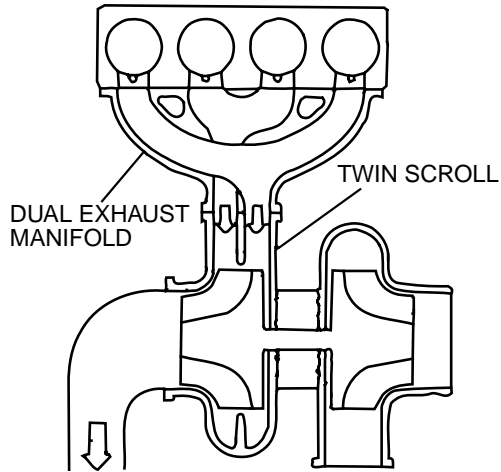

AK204159AB

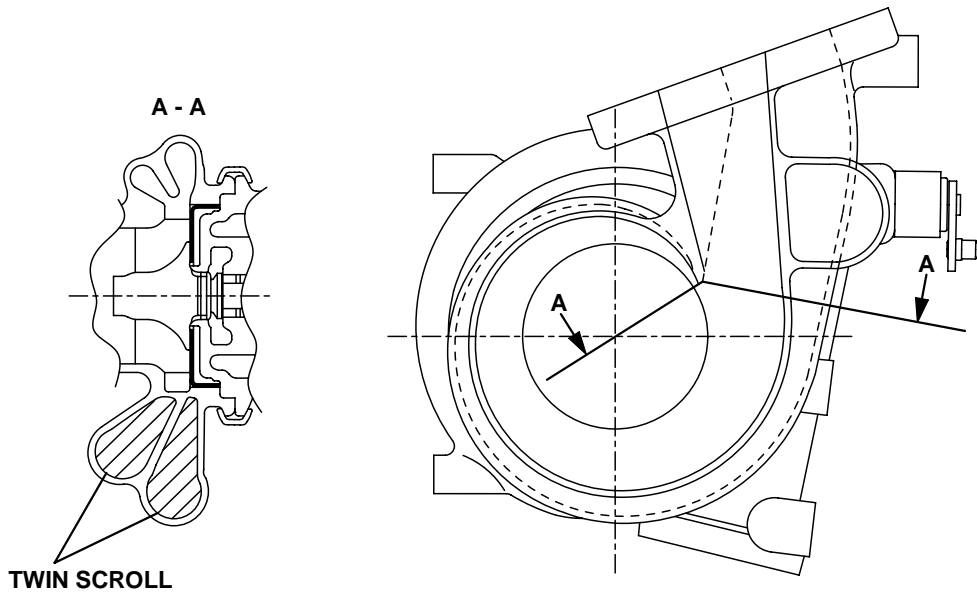

AK204068AB

EXHAUST PIPE AND MUFFLER

M2150003000039

The exhaust system consists of 3 separate sections: front exhaust pipe, center exhaust pipe, and main muffler. It has the following features:

- Straight layout of exhaust piping to reduce vibration and exhaust pressure in exhaust system.
- Rubber hangers reduce vibration from the exhaust system.

- All stainless exhaust piping reduces corrosion and heat.
- Thermal insulating cover and materials on front pipe improve emission control performance.
- Seal ring reduces driving noise and vibration during idling.
- The main muffler has a back pressure variable valve.

CONSTRUCTION DIAGRAM

