

GROUP 16

ENGINE ELECTRICAL

CONTENTS

CHARGING SYSTEM	16-2	IGNITION SYSTEM	16-32
GENERAL DESCRIPTION	16-2	GENERAL DESCRIPTION	16-32
SPECIAL TOOL	16-3	SPECIAL TOOL	16-33
CHARGING SYSTEM DIAGNOSIS	16-4	ON-VEHICLE SERVICE	16-33
ON-VEHICLE SERVICE	16-7	IGNITION COIL CHECK	16-33
GENERATOR OUTPUT LINE VOLTAGE DROP TEST	16-7	SPARK PLUG CABLE RESISTANCE CHECK	16-34
OUTPUT CURRENT TEST	16-8	SPARK PLUG CHECK AND CLEANING	16-35
REGULATED VOLTAGE TEST	16-10	CAMSHAFT POSITION SENSOR CHECK	16-35
WAVE PATTERN CHECK USING AN OSCILLOSCOPE	16-11	CRANK ANGLE SENSOR CHECK	16-35
GENERATOR ASSEMBLY	16-14	IGNITION SECONDARY VOLTAGE WAVE PATTERN CHECK USING AN OSCILLOSCOPE	16-35
REMOVAL AND INSTALLATION	16-14	IGNITION COIL	16-39
DISASSEMBLY AND ASSEMBLY	16-16	REMOVAL AND INSTALLATION	16-39
INSPECTION	16-18	CAMSHAFT POSITION SENSOR .	16-39
STARTING SYSTEM	16-21	REMOVAL AND INSTALLATION	16-39
GENERAL DESCRIPTION	16-21	CRANKSHAFT POSITION SENSOR	16-40
DIAGNOSIS	16-22	REMOVAL AND INSTALLATION	16-40
ON-VEHICLE SERVICE	16-23	KNOCK SENSOR	16-41
STARTER RELAY CHECK	16-23	REMOVAL AND INSTALLATION	16-41
STARTER MOTOR ASSEMBLY ..	16-24	SPECIFICATIONS	16-42
REMOVAL AND INSTALLATION	16-24	FASTENER TIGHTENING	
INSPECTION	16-24	SPECIFICATIONS	16-42
DISASSEMBLY AND ASSEMBLY	16-27	GENERAL SPECIFICATIONS	16-43
INSPECTION	16-29	SERVICE SPECIFICATIONS	16-43

CHARGING SYSTEM

GENERAL DESCRIPTION

M1161000100254

The charging system charges the battery with output from the generator to keep the battery charged at a constant level during varying electrical loads.

Operation

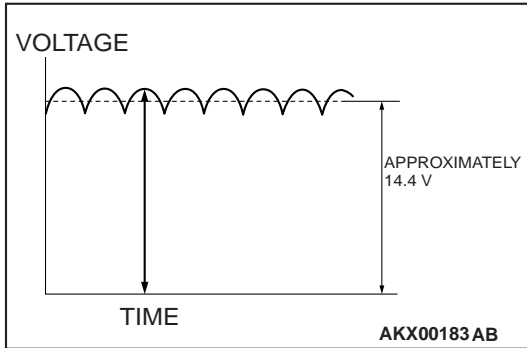

Rotation of the excited field coil generates AC voltage in the stator. This alternating current is rectified through diodes to DC voltage having a waveform shown in the illustration above. The average output voltage fluctuates slightly with the generator load condition.

When the ignition switch is turned to the "ON" position, current flows in the field coil and initial excitation of the field coil occurs. When the stator coil begins to generate power after the engine is started, the field coil is excited by the output current of the stator coil. Generator output voltage rises as the field current increases and falls as the field current decreases. When the battery positive voltage (generator S terminal voltage) reaches a regulated voltage of approximately 14.4 V, the field current is cut off. When the battery positive voltage drops below the regulated voltage, the voltage regulator regulates the output voltage to a constant level by controlling the field current. In addition, when the field current is constant, the generator output voltage rises as the engine speed increases.

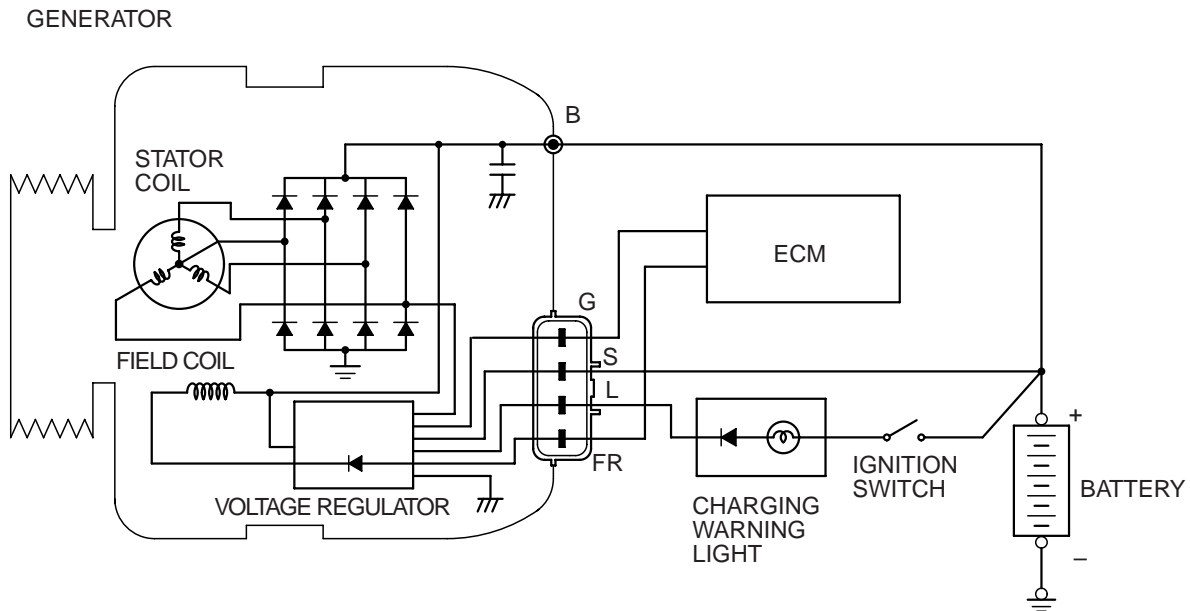

AK100054AE

SPECIAL TOOL

M1161000600204

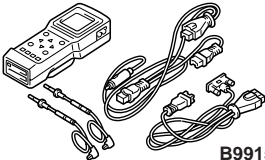
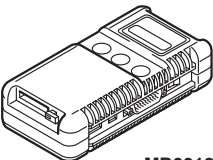
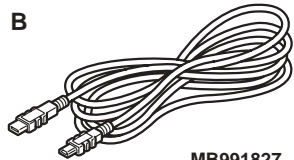
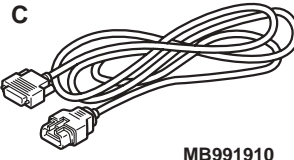
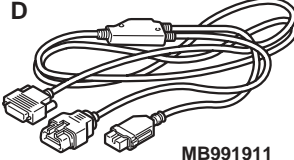
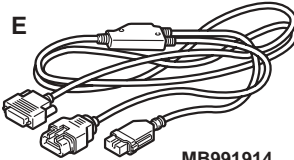
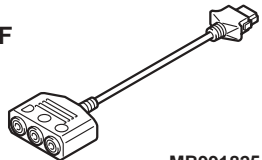
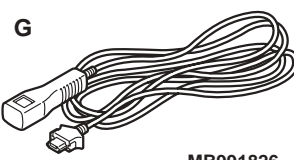
TOOL	TOOL NUMBER AND NAME	SUPERSESION	APPLICATION
 <p align="center">B991502</p>	<p>MB991502 Scan tool (MUT-II)</p>	<p>MB991496-OD</p>	<p>Checking of engine idle speed</p>
<p>A</p>  <p align="center">MB991824</p> <p>B</p>  <p align="center">MB991827</p> <p>C</p>  <p align="center">MB991910</p> <p>D</p>  <p align="center">MB991911</p> <p>E</p>  <p align="center">MB991914</p> <p>F</p>  <p align="center">MB991825</p> <p>G</p>  <p align="center">MB991826 MB991958</p>	<p>MB991958 A: MB991824 B: MB991827 C: MB991910 D: MB991911 E: MB991914 F: MB991825 G: MB991826 MUT-III sub assembly A: Vehicle Communication Interface (V.C.I.) B: MUT-III USB Cable C: MUT-III Main Harness A (Vehicles with CAN communication system) D: MUT-III Main Harness B (Vehicles without CAN communication system) E: MUT-III Main Harness C (for Chrysler models only) F: MUT-III Adapter Harness G: MUT-III Trigger Harness</p>		<p>Checking of engine idle speed</p>

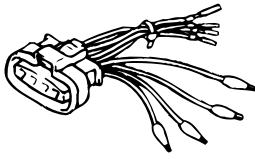
TOOL	TOOL NUMBER AND NAME	SUPERSESSION	APPLICATION
	MB991519 Generator harness connector	Tool not available	Checking of generator (S terminal voltage)

CHARGING SYSTEM DIAGNOSIS

M1161000700193

TROUBLESHOOTING HINTS

1. Charging warning light does not come on when the ignition switch is turned to "ON" position, before the engine starts.
 - Check the bulb.
2. Charging warning light does not switch off after the engine starts.
 - Check the IC voltage regulator inside the generator.
3. Discharged or overcharged battery.
 - Check the IC voltage regulator inside the generator.
4. The charging warning light illuminates dimly.
 - Check the diode (inside the combination meter or generator) for a short-circuit.

TROUBLESHOOTING GUIDE

The charging system troubleshooting guide is shown in the following chart.

STEP 1.

Q: Is the battery in good condition? (Refer to GROUP 54A, Battery – On-vehicle Service – Battery Check P.54A-3.)

YES : Go to Step 2.

NO : Charge or replace the battery.

STEP 2.

Q: Is the generator drive belt in good condition? (Refer to GROUP 00, Maintenance Service – Drive Belts P.00-37.)

YES : Go to Step 3.

NO : Adjust the belt tension or replace the belt.

STEP 3.

Q: Does the charging system warning light turn on brightly when the ignition switch is turned to the "ON" position?

YES : Go to Step 4.

- NO :**
- Check the ignition switch. (Refer to GROUP 54A, Ignition switch – Inspection [P.54A-53.](#))
 - Check for burnt-out charging system warning light bulb.
 - Check the generator. (Refer to Generator – Disassembly and assembly – Inspection [P.16-18.](#))
 - Check the charging system warning light-related circuits.

STEP 4.

Q: Does the charging warning light go out after starting the engine?

YES : Go to Step 5.

- NO :** Check the generator (Refer to Generator – Disassembly and assembly – Inspection [P.16-18.](#))

STEP 5.

Q: Is an oscilloscope available?

YES : Go to Step 6.

NO : Go to Step 7.

STEP 6.

Q: Does the oscilloscope show a normal wave pattern? (Refer to Charging system – Wave pattern check using a oscilloscope [P.16-11.](#))

YES : Go to Step 7.

- NO :** Check the generator. (Refer to Generator – Disassembly and assembly – Inspection [P.16-18.](#))

STEP 7.

- Engine: 2,500 r/min
- Headlight: ON (high beam)
- Voltage between generator "B" terminal and the positive battery terminal
OK: 0.5 V or less
- Voltage between the negative battery terminal and generator body
OK: 0.5 V or less

Q: Are the generator output line and ground line in good condition?

YES : Go to Step 8.

- NO :**
- Check the generator output line.
 - Check the generator ground line.

STEP 8.

Q: Is the output current normal? (Refer to Charging system – On vehicle service – Output current test [P.16-8.](#))

YES : Go to Step 9.

NO : Check the generator (Refer to Generator – Disassembly and assembly – Inspection [P.16-18.](#))

STEP 9.

Q: Is the regulated voltage normal? (Refer to Charging system – On vehicle service – Regulated voltage test [P.16-10.](#))

YES : Go to Step 10.

NO : Check the generator (Refer to Generator – Disassembly and assembly – Inspection [P.16-18.](#))

STEP 10.

Q: Is the voltage drops in the generator output line normal? (Refer to Charging system – On vehicle service – Generator output line voltage drop test [P.16-7.](#))

YES : Generator is normal. Check other systems.

NO : Check the output line.

ON-VEHICLE SERVICE

GENERATOR OUTPUT LINE VOLTAGE DROP TEST

M1161000900227

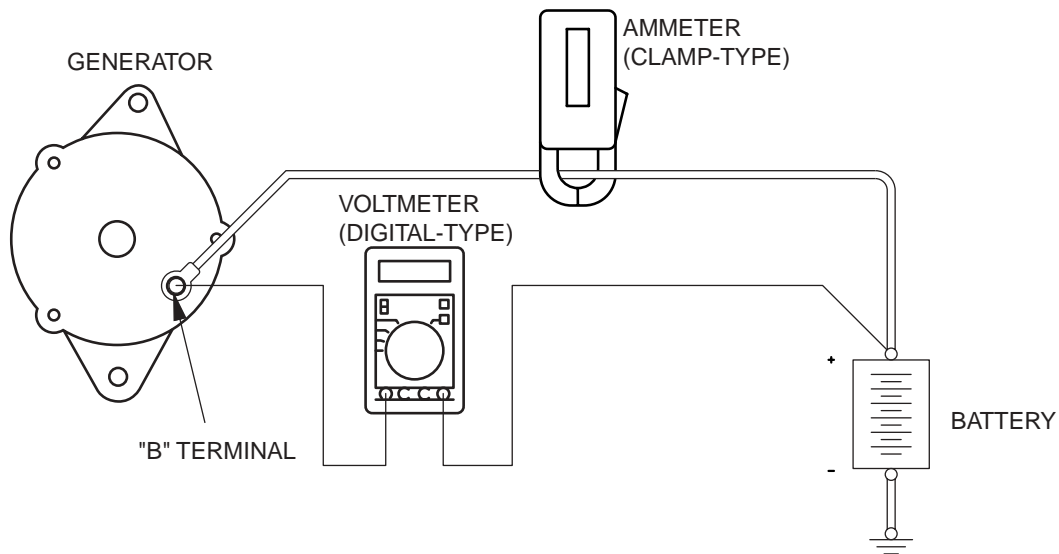

AK203361AC

Required Special Tools:

- MB991502: Scan Tool (MUT-II)
- MB991958: Scan Tool (MUT-III Sub Assembly)
 - MB991824: V.C.I.
 - MB991827: USB Cable
 - MB991911: Main Harness B

This test determines whether the wiring from the generator "B" terminal to the positive battery terminal (including the fusible link) is in good condition or not:

⚠ WARNING

Battery posts, terminals and related accessories contain lead and lead compounds. WASH HANDS AFTER HANDLING.

1. Always be sure to check the following before the test.
 - Generator installation
 - Generator drive belt tension (Refer to GROUP 00, Maintenance Service – Drive Belts P.00-37.)
 - Fusible link
 - Abnormal noise from the generator while the engine is running.
2. Turn the ignition switch to the "LOCK" (OFF) position.
3. Disconnect the negative battery cable.
4. Connect a clamp-type DC test ammeter with a range of 0 – 100 A to the generator "B" terminal output wire.

NOTE: The way of disconnecting the generator output wire and of connecting the ammeter is possibly not found the problem that the output current is dropping due to the insufficient connection between terminal "B" and the output wire.

5. Connect a digital-type voltmeter between the generator "B" terminal and the positive battery terminal. (Connect the positive lead of the voltmeter to the "B" terminal, and then connect the negative lead of the voltmeter to the positive battery cable.)
6. Reconnect the negative battery cable.
7. Connect an engine tachometer, scan tool MB991502 or MB991958.
8. Leave the hood open.
9. Start the engine.
10. With the engine running at 2,500 r/min, turn the headlights and other lights on and off to adjust the generator load so that the value displayed on the ammeter is slightly above 30 A.

Read the voltmeter. Voltage reading at or below limit value means voltage drop between generator and battery is OK.

Limit value: maximum 0.3 V

NOTE: When the generator output is high and the value displayed on the ammeter does not decrease to 30 A, set the value to 40 A. Read the value displayed on the voltmeter at this time.

In this case the limit value becomes maximum 0.4 V.

Adjust the engine speed by gradually decreasing it until the value displayed on the ammeter is 30 A. Take a reading of the value displayed on the voltmeter at this time.

11. If the value displayed on the voltmeter is above the limit value, there is probably a malfunction in the generator output wire. Check the wiring between the generator "B" terminal and the positive battery terminal (including fusible link).

If a terminal is not sufficiently tight or if the harness has become discolored due to overheating, repair and then test again.

12. After the test, run the engine at idle.
13. Turn off all lights and turn the ignition switch to the "LOCK" (OFF) position.
14. Disconnect the engine tachometer, scan tool MB991502 or MB991958.
15. Disconnect the negative battery cable.
16. Disconnect the ammeter and voltmeter.
17. Connect the negative battery cable.
18. Run the engine for 10 minutes at an idle.

OUTPUT CURRENT TEST

M1161001000216

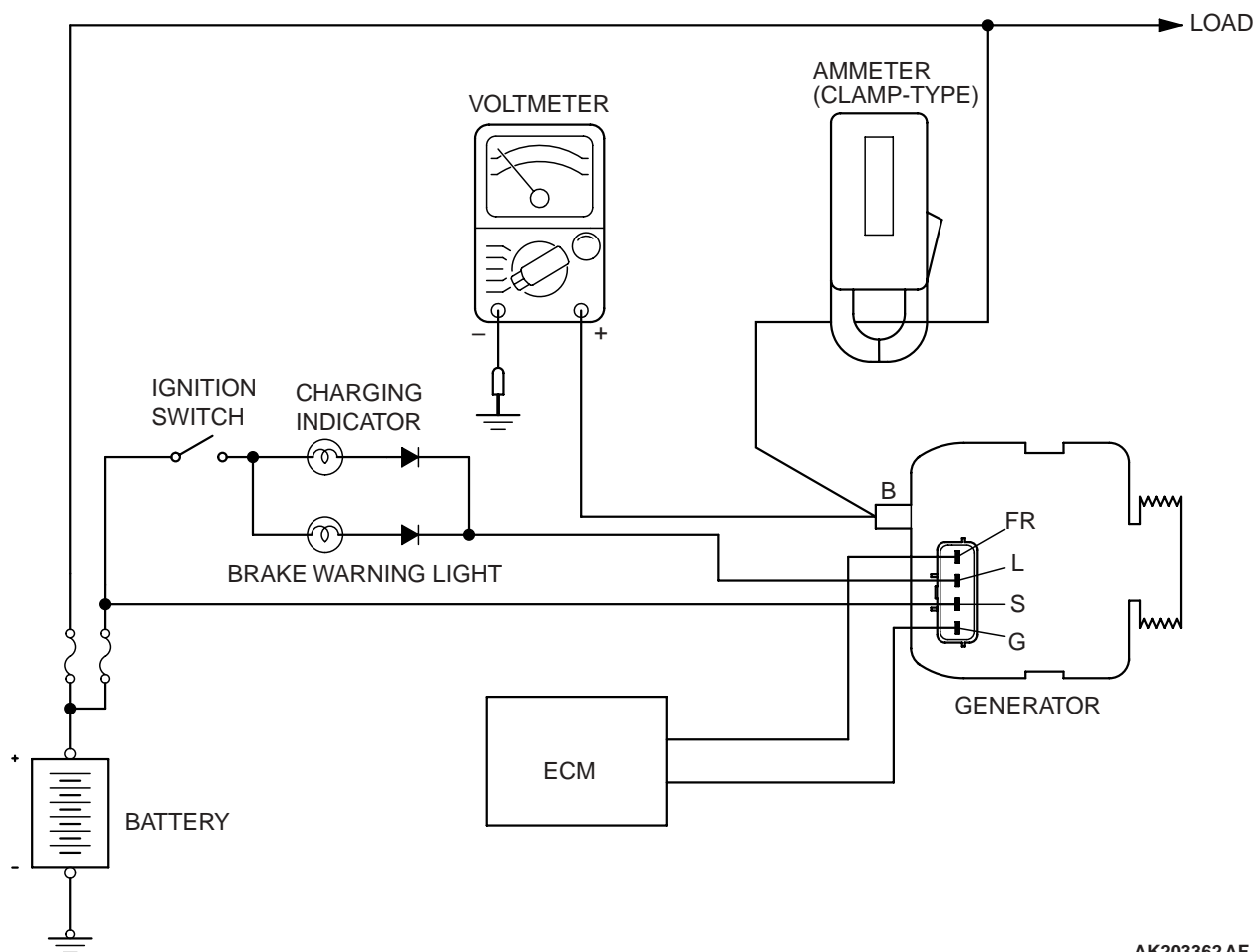

AK203362 AF

Required Special Tools:

- MB991502: Scan Tool (MUT-II)
- MB991958: Scan Tool (MUT-III Sub Assembly)
 - MB991824: V.C.I.
 - MB991827: USB Cable
 - MB991911: Main Harness B

This test determines whether the generator outputs normal current. For best results, use a charging system tester. If not available, follow the steps below.

⚠ WARNING

Battery posts, terminals and related accessories contain lead and lead compounds. WASH HANDS AFTER HANDLING.

1. Before the test, always be sure to check the following.
 - Generator installation
 - Battery (Refer to GROUP 54A, Battery – On-vehicle Service – Battery Check P.54A-3.)

NOTE: The battery to be used should be slightly discharged. The load in a fully-charged battery will be insufficient and the test may not be able to be carried out correctly.

- Generator drive belt tension (Refer to GROUP 00, Maintenance Service – Drive Belts P.00-37.)
 - Fusible link
 - Abnormal noise from the generator while the engine is running.
2. Turn the ignition switch to the "LOCK" (OFF) position.
 3. Disconnect the negative battery cable.

⚠ WARNING

Never use clips to connect the line. Loose connections (for example, using clips) will lead to a serious accident because of high current.

4. Connect a clamp-type DC test ammeter with a range of 0 – 100 A to the generator "B" terminal output wire.
5. Connect a voltmeter with a range of 0 – 20 V between the generator "B" terminal and ground. (Connect the positive lead of the voltmeter to the "B" terminal, and then connect the negative lead of the voltmeter to ground.)
6. Connect the negative battery cable.
7. Connect an engine tachometer, scan tool MB991502 or MB991958.
8. Leave the hood open.
9. Check to be sure that the reading on the voltmeter is equal to the battery positive voltage.

NOTE: If the voltage is 0 V, the cause is probably an open circuit in the wire or fusible link between the generator "B" terminal and the battery positive terminal or malfunctioning voltmeter.

10. After turning on the headlights, start the engine.

NOTE: Because the current from the battery will soon drop after the engine is started, step 11 should be carried out as quickly as possible in order to obtain the maximum current output value.

11. Immediately after setting the headlights to high beam and turning the heater blower switch to the highest position, increase the engine speed to 2,500 r/min and read the maximum current output value displayed on the ammeter.

Limit value: 70 % of nominal current output

NOTE: For the nominal current output, refer to the Generator Specifications.

NOTE: The current output value will depend on the electrical load and the temperature of the generator body.

NOTE: If the electrical load is small while testing, the specified level of current may not be output even though the generator is normal. In such cases, increase the electrical load by leaving the headlights turned on for some time to discharge the battery or by using the lighting system in another vehicle, and then test again.

NOTE: The specified level of current also may not be output if the temperature of the generator body or the ambient temperature is too high. In such cases, cool the generator and then test again.

12. The reading on the ammeter should be above the limit value. If the reading is below the limit value and the generator output wire is normal, remove the generator from the engine and check the generator.
13. Run the engine at idle speed after the test.
14. Turn the ignition switch to the "LOCK" (OFF) position.
15. Disconnect the engine tachometer, scan tool MB991502 or MB991958.
16. Disconnect the negative battery cable.
17. Disconnect the ammeter and voltmeter .
18. Connect the negative battery cable.
19. Run the engine for 10 minutes at an idle.

REGULATED VOLTAGE TEST

M1161001100224

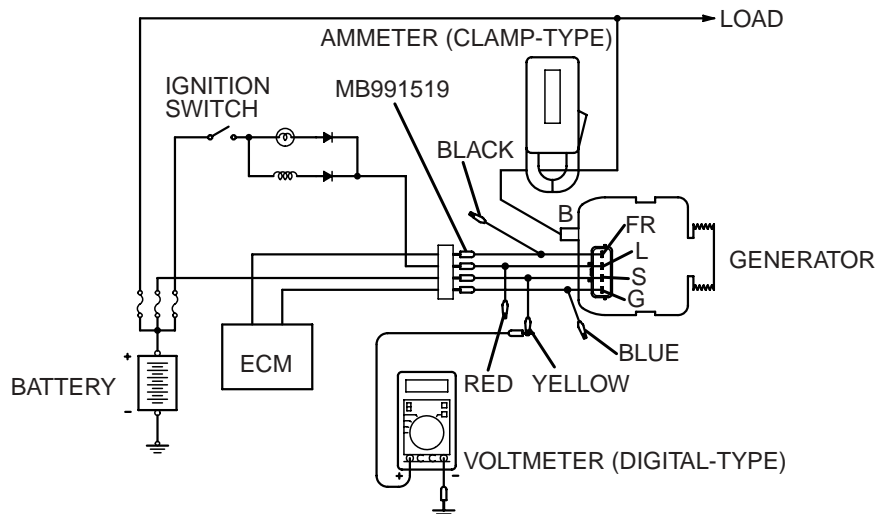

AK202360AF

Required Special Tools:

- MB991502: Scan Tool (MUT-II)
- MB991958: Scan Tool (MUT-III Sub Assembly)
 - MB991824: V.C.I.
 - MB991827: USB Cable
 - MB991911: Main Harness B
- MB991519: Generator Harness Connector

This test determines whether the voltage regulator is correctly controlling the generator output voltage.

⚠ WARNING

Battery posts, terminals and related accessories contain lead and lead compounds. WASH HANDS AFTER HANDLING.

1. Always be sure to check the following before the test:
 - Generator installation
 - Check to be sure that the battery installed in the vehicle is fully charged. (Refer to GROUP 54A, Battery – On-vehicle Service – Battery Check P.54A-3.)
 - Generator drive belt tension (Refer to GROUP 00, Maintenance Service – Drive Belts P.00-37.)
 - Fusible link
 - Abnormal noise from the generator while the engine is running.
2. Turn the ignition switch to the "LOCK" (OFF) position.
3. Disconnect the negative battery cable.

4. Use the special tool (Generator harness connector: MB991519) to connect a digital-type voltmeter between the generator "S" terminal and ground. (Connect the positive lead of the voltmeter to the "S" terminal, and then connect the negative lead of the voltmeter to a secure ground or to the negative battery terminal.)
5. Connect a clamp-type DC test ammeter with a range of 0 – 100 A to the generator "B" terminal output wire.
6. Reconnect the negative battery cable.
7. Connect an engine tachometer, scan tool MB991502 or MB991958.
8. Turn the ignition switch to the "ON" position and check that the reading on the voltmeter is equal to the battery positive voltage.

NOTE: If the voltage is 0 V, the cause is probably an open circuit in the wire or fusible link between the generator "S" terminal and the battery positive terminal or malfunctioning voltmeter.
9. Check to be sure that all lights and accessories are off.
10. Start the engine.
11. Increase the engine speed to 2,500 r/min.
12. Read the value displayed on the voltmeter when the current output by the generator becomes 10 A or less.

13.If the voltage reading conforms to the value in the voltage regulation table, then the voltage regulator is operating normally.

If the voltage is outside the standard value, there is a malfunction of the voltage regulator or the generator (Refer to the following table).

14.After the test, lower the engine speed to idle.

15.Turn the ignition switch to the "LOCK" (OFF) position.

16.Disconnect the engine tachometer, scan tool MB991502 or MB991958.

17.Disconnect the negative battery cable.

18.Disconnect the ammeter and voltmeter.

19.Connect the negative battery cable.

20.Run the engine for 10 minutes at an idle.

VOLTAGE REGULATION TABLE

INSPECTION TERMINAL	VOLTAGE REGULATOR AMBIENT TEMPERATURE [°C (°F)]	STANDARD VALUE (V)
Terminal "S"	-20 (-4)	14.2 – 15.4
	20 (68)	13.9 – 14.9
	60 (140)	13.4 – 14.5
	80 (176)	13.1 – 14.2

**WAVE PATTERN CHECK USING AN
OSCILLOSCOPE**

M1161001200094

Measurement Method

Connect the oscilloscope probe to the generator "B" terminal.

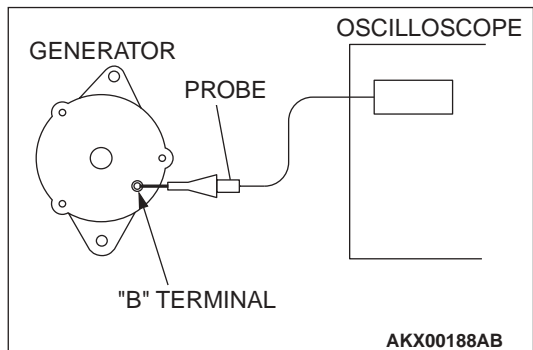

Standard Waveform

OBSERVATION CONDITIONS	
FUNCTION	SPECIAL PATTERNS
Pattern height	Variable
Variable knob	Adjust while viewing the wave pattern
Pattern selector	Raster
Engine revolutions	Curb idle speed

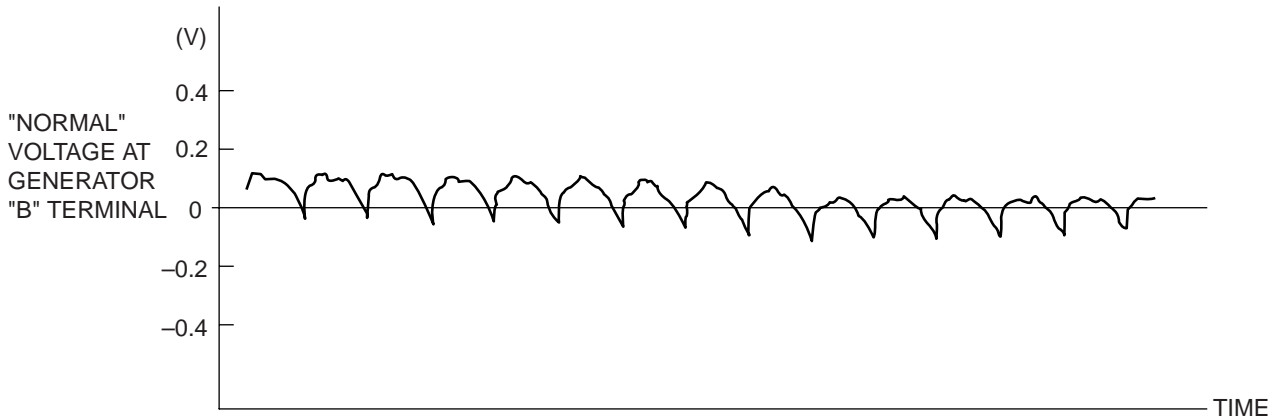

AKX00189 AD

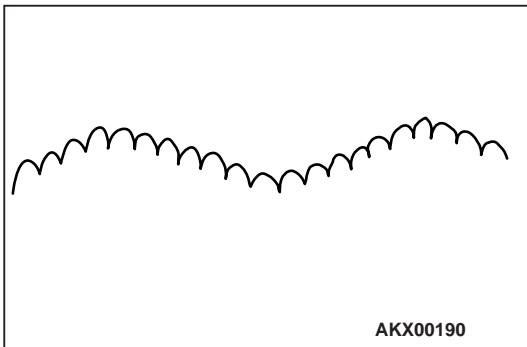





NOTE: The voltage waveform of the generator "B" terminal can undulate as shown at left. This waveform is produced when the regulator operates according to fluctuations in the generator load (current), and is normal for the generator. If the ripple height is abnormally high (approximately 2 V or more during idling), the wires between the generator B terminal and the battery have broken due to fuse blowing, etc. The generator is usually operating properly.

Abnormal Waveforms Examples

NOTE: The size of the waveform patterns can differ greatly, depending on the adjustment of the variable knob on the oscilloscope.

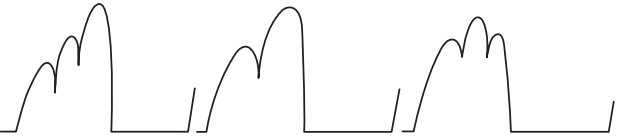
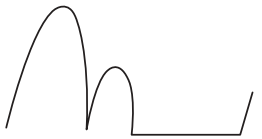
NOTE: Identification of abnormal waveforms is easier when there is a large output current (regulator is not operating). (Waveforms can be observed when the headlights are illuminated.)

NOTE: Check the conditions of the charging system warning light (illuminated/not illuminated) also, and carry out a total check.

ABNORMAL WAVEFORMS	PROBABLE CAUSE
<p>Example 1</p>  <p align="right">AKX00191</p>	<p>Open circuit in diode</p>
<p>Example 2</p>  <p align="right">AKX00192</p>	<p>Short-circuit in diode</p>
<p>Example 3</p>  <p align="right">AKX00193</p>	<p>Open circuit in stator coil</p>
<p>Example 4</p>  <p align="right">AKX00194</p>	<p>Short-circuit in stator coil</p>
<p>Example 5</p>  <p align="right">AKX00195</p>	<p>Open circuit in supplementary diode</p>

GENERATOR ASSEMBLY

REMOVAL AND INSTALLATION

M1161001400429

⚠ CAUTION

If the vehicle is equipped with the Brembo disc brake, during maintenance, take care not to contact the parts or tools to the caliper because the paint of caliper will be scratched.

Pre-removal Operation

- Under Cover Removal (Refer to GROUP 51, Front Bumper P.51-2).
- Strut Tower Bar Removal (Refer to GROUP 42, Strut Tower Bar P.42-12).
- Crossmember Bar Removal (Refer to GROUP 32, Engine Roll Stopper and Centermember P.32-6).
- Front Exhaust Pipe Assembly Removal (Refer to GROUP 15, Exhaust Pipe and Main Muffler P.15-23).

Post-installation Operation

- Front Exhaust Pipe Assembly Installation (Refer to GROUP 15, Exhaust Pipe and Main Muffler P.15-23).
- Crossmember Bar Installation (Refer to GROUP 32, Engine Roll Stopper and Centermember P.32-6).
- Strut Tower Bar Installation (Refer to GROUP 42, Strut Tower Bar P.42-12).
- Drive Belt Tension Adjustment [Refer to GROUP 00, Maintenance Service – Drive Belts (Check Condition) P.00-37].
- Under Cover Installation (Refer to GROUP 51, Front Bumper P.51-2).

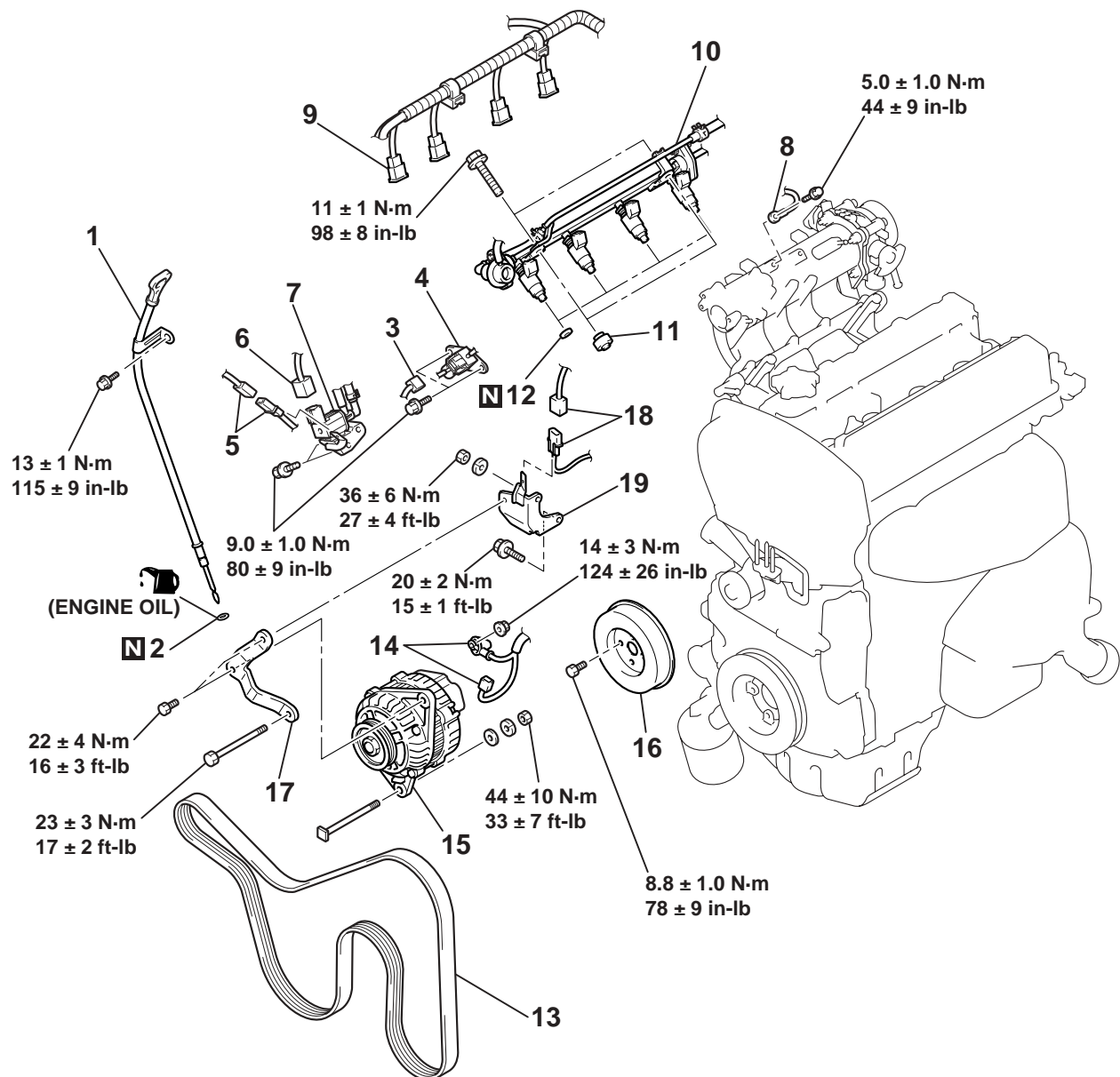

AC210295 AB

REMOVAL STEPS

REMOVAL STEPS (Continued)

- <<A>>
1. OIL LEVEL GAUGE AND GUIDE ASSEMBLY
 2. O-RING <>
 3. FUEL PRESSURE SOLENOID CONNECTOR
 4. FUEL PRESSURE SOLENOID
 5. KNOCK SENSOR CONNECTOR
 6. EVAPORATIVE EMISSION PURGE SOLENOID CONNECTOR <<C>>
 7. EVAPORATIVE EMISSION PURGE SOLENOID
 8. GROUND CABLE CONNECTION
 9. FUEL INJECTOR CONNECTORS
 10. FUEL INJECTOR, FUEL RAIL, FUEL RETURN PIPE AND FUEL PRESSURE REGULATOR ASSEMBLY

11. INSULATORS
12. INSULATORS
13. DRIVE BELT
14. GENERATOR CONNECTOR AND TERMINAL
 - ENGINE MOUNT (REFER TO GROUP 32, ENGINE MOUNT P.32-3).
15. GENERATOR
16. WATER PUMP PULLEY
17. GENERATOR BRACE
18. CRANKSHAFT POSITION SENSOR CONNECTOR
19. GENERATOR BRACE STAY

REMOVAL SERVICE POINTS

<<A>> FUEL INJECTOR, FUEL RAIL, FUEL RETURN PIPE AND FUEL PRESSURE REGULATOR ASSEMBLY REMOVAL

After loosening the fuel rail mounting bolts, move the fuel injector, fuel rail, fuel return pipe and the fuel pressure regulator as an assembly aside in order to make room for the generator removal.

<> DRIVE BELT REMOVAL

The following operations will be needed due to the serpentine

⚠ CAUTION

To reuse the drive belt, draw an arrow indicating the rotating direction (to the right) on the back of the belt using chalk, etc.

1. Securely insert the spindle handle or ratchet handle with a 12.7mm (1/2-inch) insertion angle into the jig hole of the auto-tensioner, and turn the auto-tensioner counterclockwise until it hits the stopper.
2. Align hole A with hole B, insert an L-shaped hexagon wrench, etc. to fix and then remove the drive belt.

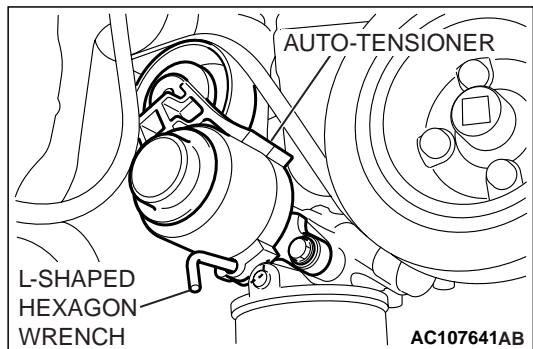
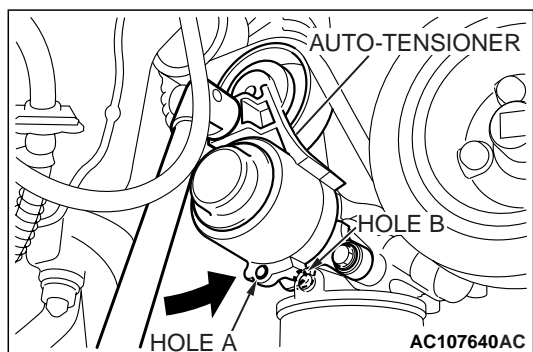

<<C>> GENERATOR REMOVAL

Push up the engine with a floor jack to the top and remove the generator upward from engine room.

DISASSEMBLY AND ASSEMBLY

M1161001600144

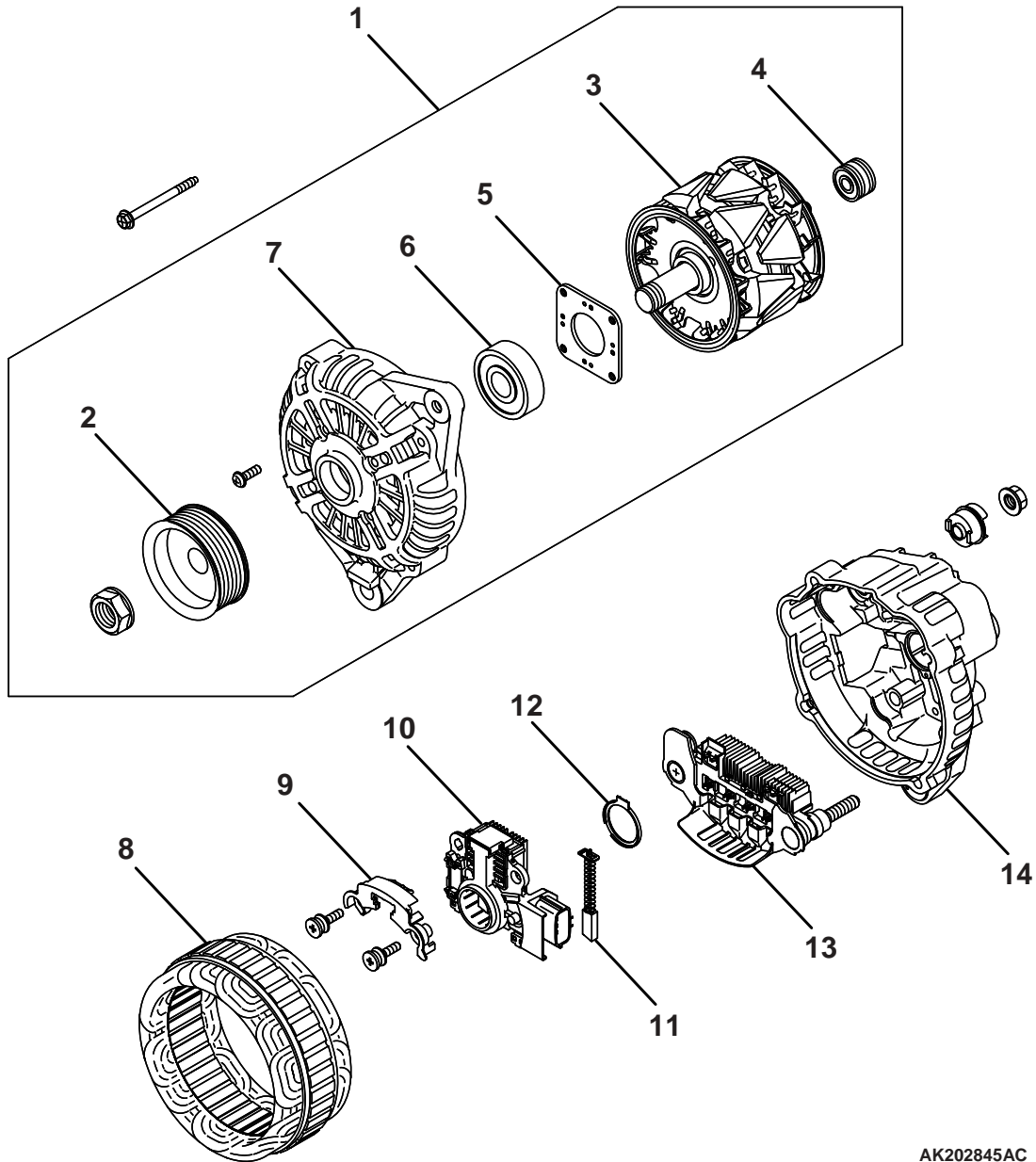

AK202845AC

- <<A>>
<>
>>B<<
- DISASSEMBLY STEPS**
1. FRONT BRACKET ASSEMBLY
 2. ALTERNATOR PULLEY
 3. ROTOR
 4. REAR BEARING
 5. BEARING RETAINER
 6. FRONT BEARING
 7. FRONT BRACKET

- <<C>>
<<C>> >>A<<
- DISASSEMBLY STEPS (Continued)**
8. STATOR
 9. PLATE
 10. REGULATOR ASSEMBLY
 11. BRUSH
 12. RUBBER PACKING
 13. RECTIFIER
 14. REAR BRACKET

DISASSEMBLY SERVICE POINTS

<<A>> FRONT BRACKET ASSEMBLY REMOVAL

⚠ CAUTION

Do not insert the screwdriver blades too deep. Doing so could damage the stator coil.

Insert the blades of screwdrivers between the front bracket assembly and stator core, and pry and separate them with the screwdrivers.

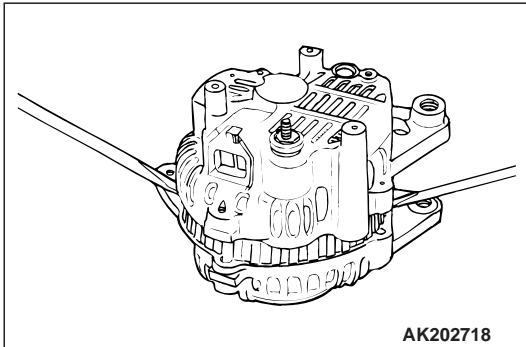

<> ALTERNATOR PULLEY REMOVAL

⚠ CAUTION

Perform operation carefully not to damage the rotor.

Clamp the rotor in a vise with the pulley facing up to remove the pulley.

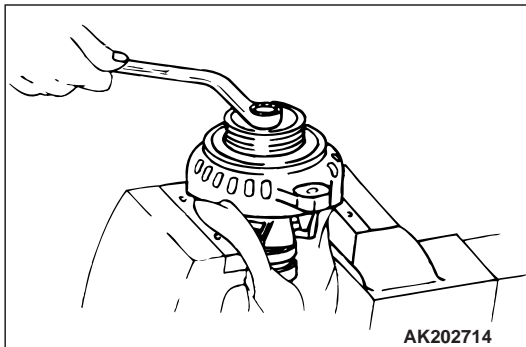

<<C>> STATOR / REGULATOR ASSEMBLY REMOVAL

⚠ CAUTION

- Use a 180 – 250 W soldering iron, and finish unsoldering within four seconds. Diodes will be damaged by heat if unsoldering time is too long.
- Avoid applying undue force to the diode leads.

1. Unsolder the stator leads from the main diode of the rectifier assembly when the stator is removed.
2. When removing the rectifier assembly from the regulator assembly, undo the soldered points on the rectifier assembly.

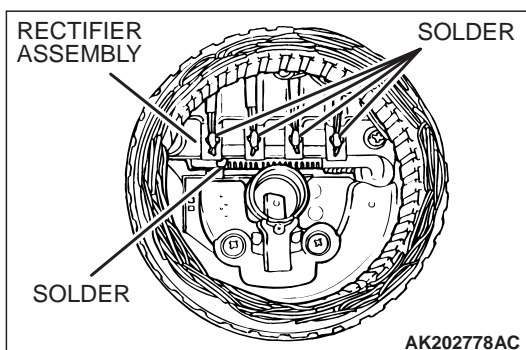

REASSEMBLY SERVICE POINTS

>>A<< REGULATOR ASSEMBLY INSTALLATION

After installing the regulator assembly, insert a piece of wire through the hole in the rear bracket while pressing the brush to keep the brush against movement.

NOTE: Holding the brush with the wire facilitates installation of the rotor.

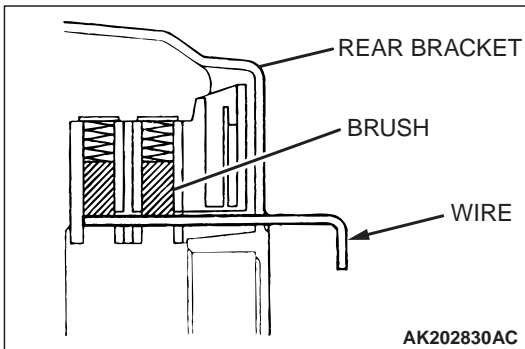
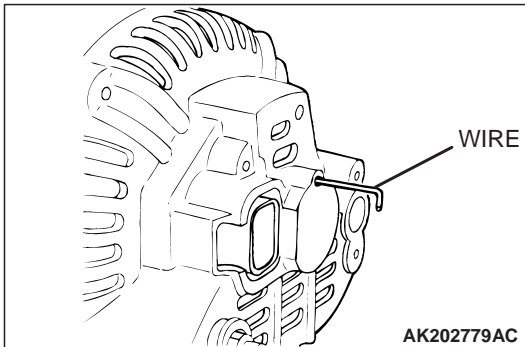

>>B<< ROTOR INSTALLATION

Remove the brush holding wire after the rotor has been installed.

INSPECTION (DISASSEMBLY AND ASSEMBLY)

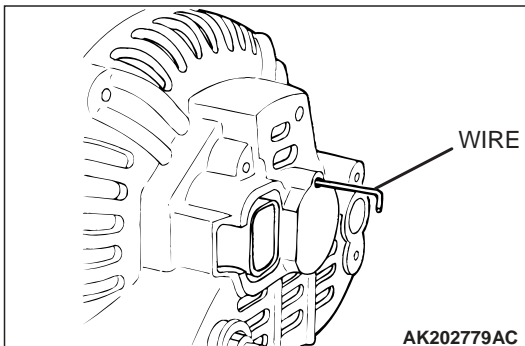

M1161001700118

ROTOR

1. Measure the resistance between the two slip rings of the rotor coil to check the continuity between them. Replace the rotor if the resistance is not within the standard value range.

Standard value: 3 – 5 Ω

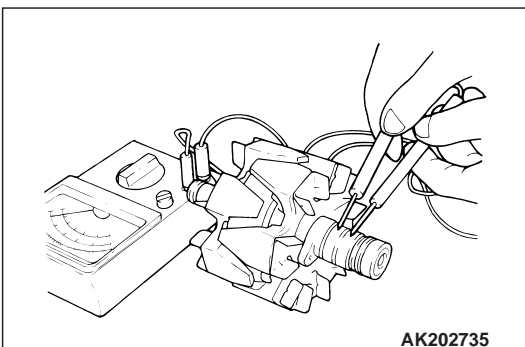

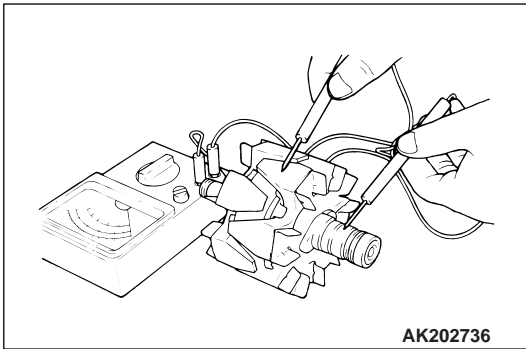

2. Check the continuity between the slip rings and core.
If continuity is present, replace the rotor.

STATOR

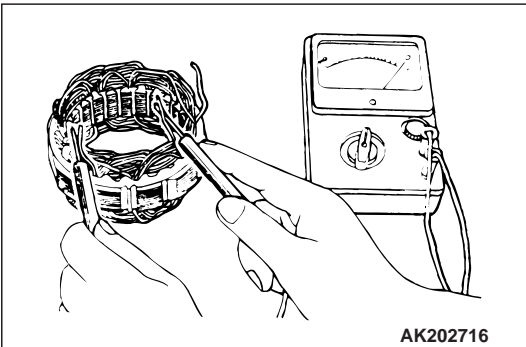

1. Check the continuity between coil leads.
If there is no continuity, replace the stator.

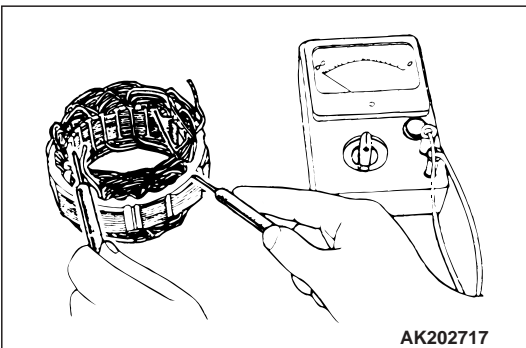

2. Check the continuity between coil and core.
If there is no continuity, replace the stator.

RECTIFIER ASSEMBLY

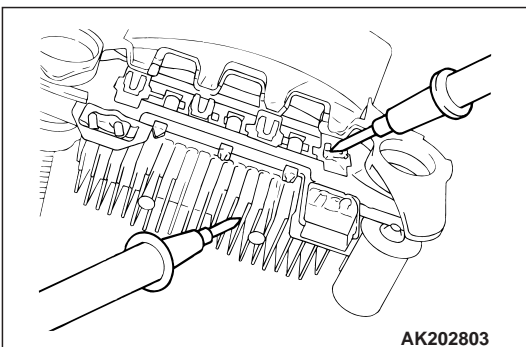

1. Check the condition of the (+) heat sink by checking continuity between the (+) heat sink and each of the stator coil lead connecting terminals.
If continuity is present for both terminals, the diode is shorted. Replace the rectifier assembly.

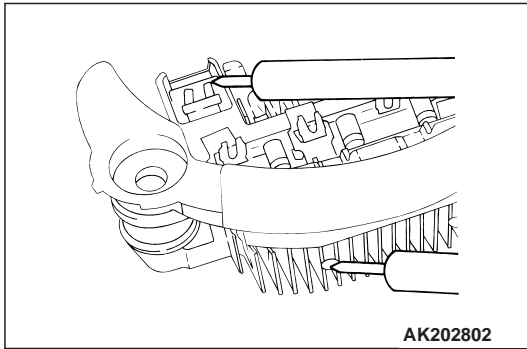

2. Check the condition of the (-) heat sink by checking continuity between the (-) heat sink and each of the stator coil lead connecting terminals.
If continuity is present in both directions, the diode is shorted. Replace the rectifier assembly.

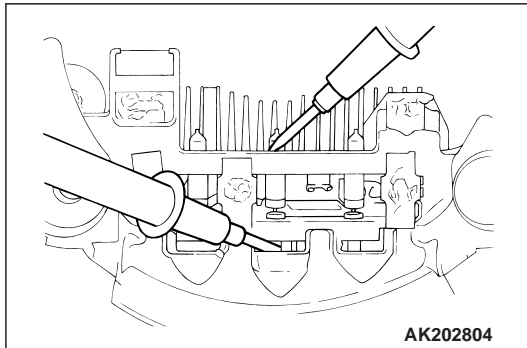

3. Check the condition of the diode trio by testing continuity of each of the three diodes using a circuit tester connected to both sides of the diode. Connect in a polarity and then reverse the polarity for each test.
If continuity exists or no continuity exists for both polarities, the diode is defective. Replace the rectifier assembly if any of the diodes is defective.

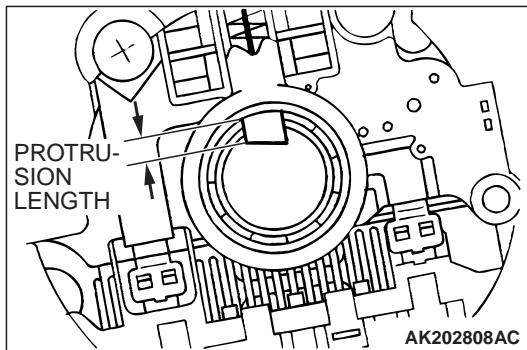

BRUSH

1. Measure the length of the protrusion of the brush. Replace the brush if the protrusion length is shorter than the limit.
Limit: 2 mm minimum
2. Unsolder the lead of the brush. The brush will come out, becoming ready for removal.

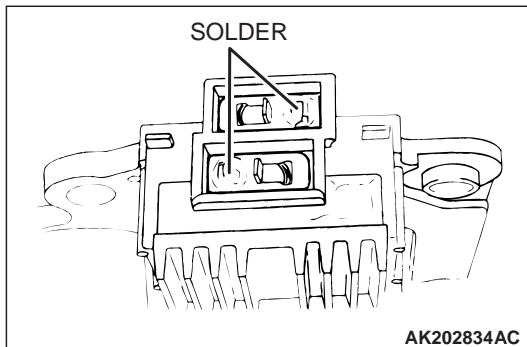

3. Install a new brush by pushing it into the holder as shown in the drawing and soldering the lead.

STARTING SYSTEM

GENERAL DESCRIPTION

If the ignition switch is turned to the "START" position, current flows in the coil provided inside magnetic switch, attracting the plunger. When the plunger is attracted, the lever connected to the plunger is actuated to engage the overrunning clutch with the ring gear.

At the same time, attracting the plunger will turn on the magnetic switch, allowing the B terminal and M terminal to conduct. Thus, current flows to engage the starter motor.

When the ignition switch is returned to the "ON" position after starting the engine, the overrunning clutch is disengaged from the ring gear.

An overrunning clutch is provided between the pinion and the armature shaft, to prevent damage to the starter.

M1162000100172

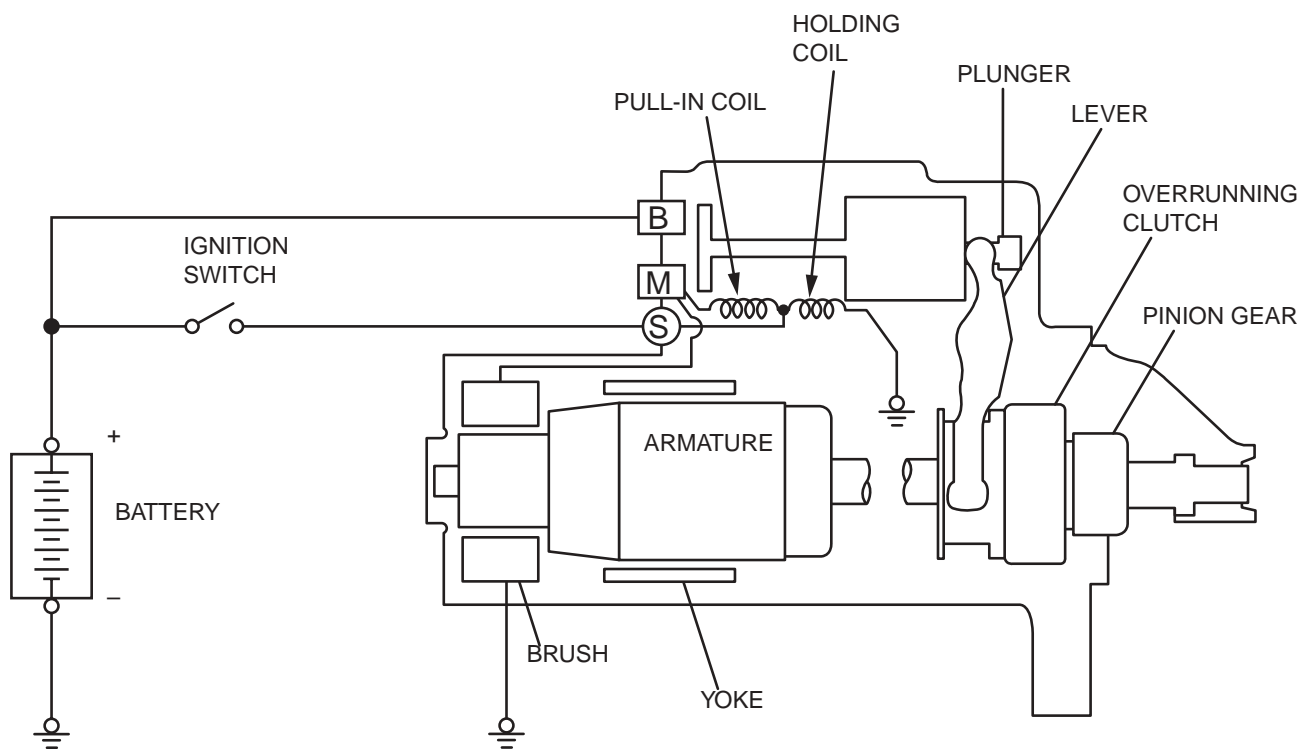

AK202970AC

OPERATION

- The clutch pedal position switch contact is switched OFF when the clutch pedal is depressed. When the ignition switch is then switched to the "ST" position, electricity flows to the starter relay and the starter motor, the contact (magnetic switch) of the starter is switched ON and the starter motor is activated.

NOTE: If the ignition switch is switched to the "ST" position without the clutch pedal being depressed, electricity flows to the starter relay (coil), the clutch pedal position switch (contacts) and to ground, with the result that the contacts of the starter relay are switched OFF, and because the power to the starter motor is thereby interrupted, the starter motor is not activated.

DIAGNOSIS**TROUBLESHOOTING HINTS**

The starter motor does not operate at all.

- Check the starter (coil).
- Check for poor connection at the battery terminals and starter.
- Check starter relay.
- Check the clutch pedal position switch.

The starter motor doesn't stop

- Check the starter (magnetic switch).

TROUBLESHOOTING GUIDE

The starting system troubleshooting guide is shown in the following chart.

STEP 1.

Q: Is the battery in good condition? (Refer to GROUP 54A, Battery – On-vehicle Service – Battery Check P.54A-3.)

YES : Go to Step 2.

NO : Charge or replace the battery.

STEP 2.

- Disconnect the starter motor "S" (solenoid) terminal connector.
- Using a jumper wire, apply battery positive voltage to the starter motor "S" (solenoid) terminal.
- Check the engine condition.
OK: Turns normally

Q: Does the starter motor operate normally?

- YES :**
- Check the ignition switch (Refer to GROUP 54A, Ignition Switch – Inspection P.54A-53.)
 - Check the starter relay and clutch pedal position switch.
 - Check the line between the battery and starter motor "S" (solenoid) terminal.

NO : Go to Step 3.

STEP 3.

- Check the cable between starter "B" (battery) terminal and battery positive terminal for connection and continuity.

Q: Is the starter cable in good condition?

YES : Go to Step 4.

NO : Repair or replace the cable.

STEP 4.

- Check the connection and the continuity of the cable between the starter motor body and the negative battery terminal.

Q: Is the ground cable in good condition?

YES : Go to Step 5.

NO : Repair or replace the cable.

STEP 5.

Q: Is the starter motor in good condition? (Refer to Starting system – Starter motor – Inspection P.16-24.)

YES : Starter motor is normal. Check the excessive rotational resistance of the engine.

NO : Replace the starter motor.

ON-VEHICLE SERVICE

STARTER RELAY CHECK

M1162001400176

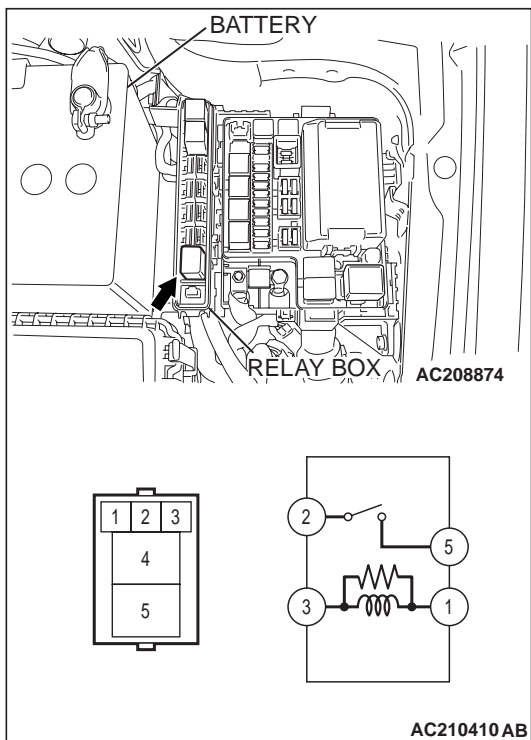

BATTERY VOLTAGE	TERMINAL NUMBER TO BE CONNECTED TO TESTER	CONTINUITY TEST RESULTS
Not applied	2 – 5	Open circuit
<ul style="list-style-type: none"> • Connect terminal 1 to the positive battery terminal • Connect terminal 3 to the negative battery terminal 	2 – 5	Less than 2 ohms

**STARTER MOTOR ASSEMBLY
REMOVAL AND INSTALLATION**

M1162001000480

Pre-removal and Post-installation Operation

- Under Cover Removal and Installation (Refer to GROUP 51, Front Bumper P.51-2).
- Crossmember Bar Removal and Installation (Refer to GROUP 32, Engine Roll Stopper and Centermember P.32-6).
- Front Exhaust Pipe Assembly Removal and Installation (Refer to GROUP 15, Exhaust Pipe and Main Muffler P.15-23).

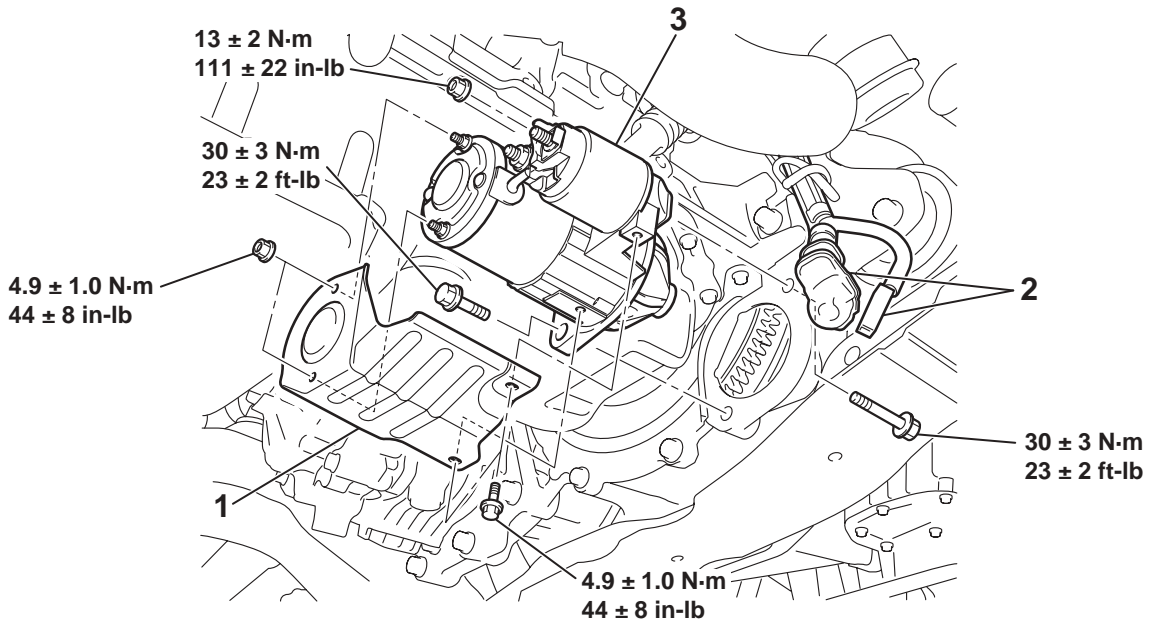

AC210296AB

REMOVAL STEPS

1. STARTER COVER

REMOVAL STEPS (Continued)

2. STARTER CONNECTOR AND TERMINAL
3. STARTER ASSEMBLY

INSPECTION

M1162001100153

PINION GAP ADJUSTMENT

1. Disconnect the field coil wire from the M-terminal of the magnetic switch.
2. Connect a 12-volt battery between the S-terminal and M-terminal.

CAUTION

This test must be performed quickly (in less than 10 seconds) to prevent the coil from burning.

3. Set the switch to "ON", and the pinion will move out.

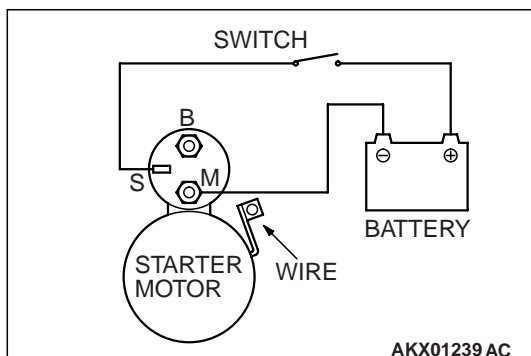

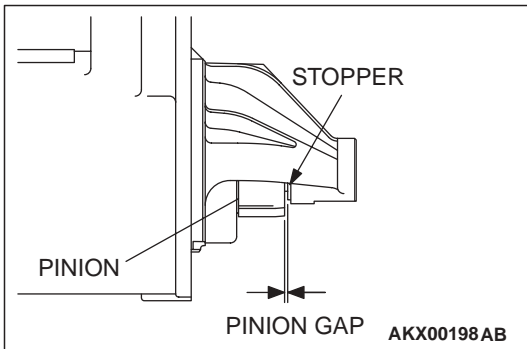

4. Check the pinion-to-stopper clearance (pinion gap) with a feeler gauge.

Standard value: 0.5 – 2.0 mm (0.02 – 0.07 inch)

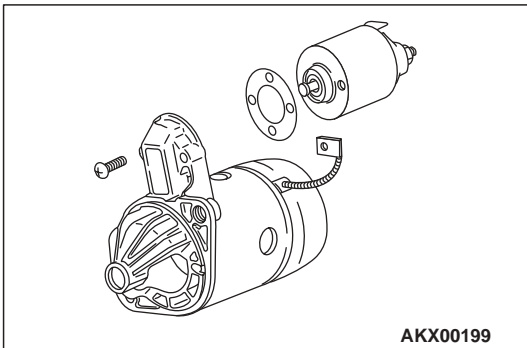

5. If the pinion gap is out of specification, adjust by adding or removing gasket(s) between the magnetic switch and front bracket.

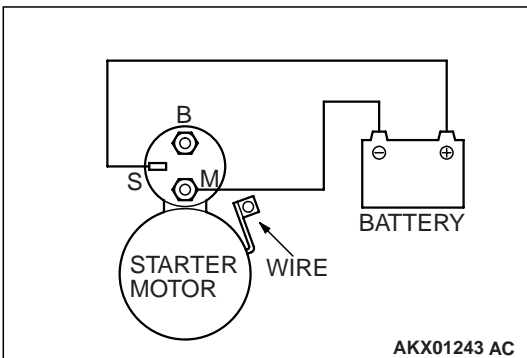

MAGNETIC SWITCH PULL-IN TEST

1. Disconnect the field coil wire from the M-terminal of the magnetic switch.

⚠ CAUTION

This test must be performed quickly (in less than 10 seconds) to prevent the coil from burning.

2. Connect a 12-volt battery between the S-terminal and M-terminal.
3. If the pinion moves out, the pull-in coil is good. If it doesn't, replace the magnetic switch.

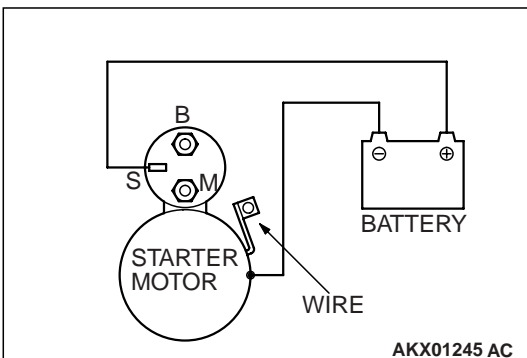

MAGNETIC SWITCH HOLD-IN TEST

1. Disconnect the field coil wire from the M-terminal of the magnetic switch.

⚠ CAUTION

This test must be performed quickly (in less than 10 seconds) to prevent the coil from burning.

2. Connect a 12-volt battery between the S-terminal and body.
3. Manually pull out the pinion as far as the pinion stopper position.
4. If the pinion remains out, everything is operating properly. If the pinion moves in, the hold-in circuit is open. Replace the magnetic switch.

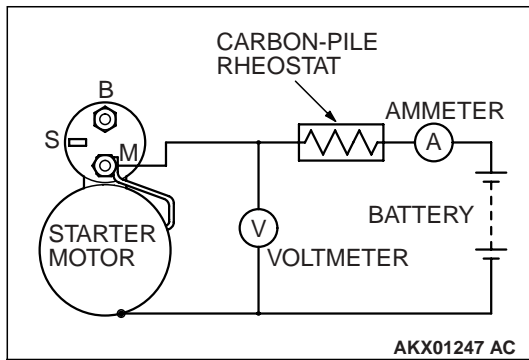
**FREE RUNNING TEST**

1. Place the starter motor in a vise equipped with soft jaws and connect a fully-charged 12-volt battery to the starter motor as follows:
2. Connect a test ammeter (100-ampere scale) and carbon pile rheostat in series between the positive battery terminal and starter motor terminal.
3. Connect a voltmeter (15-volt scale) across the starter motor.
4. Rotate carbon pile to full-resistance position.
5. Connect the battery cable from the negative battery terminal to the starter motor body.
6. Adjust the rheostat until the battery positive voltage shown by the voltmeter is 11 V.
7. Confirm that the maximum amperage is within the specifications and that the starter motor turns smoothly and freely.

Current: maximum 95 Amps

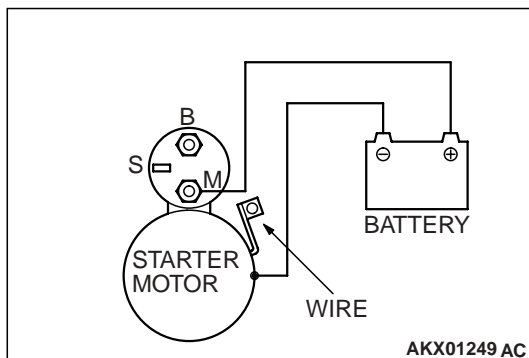
**MAGNETIC SWITCH RETURN TEST**

1. Disconnect the field coil wire from the M-terminal of the magnetic switch.

⚠ CAUTION

This test must be performed quickly (in less than 10 seconds) to prevent the coil from burning.

2. Connect a 12-volt battery between the M-terminal and body.

⚠ WARNING

Be careful not to get your fingers caught when pulling out the pinion.

3. Pull the pinion out and release. If the pinion quickly returns to its original position, everything is operating properly. If it doesn't, replace the magnetic switch.

DISASSEMBLY AND ASSEMBLY

M1162001200172

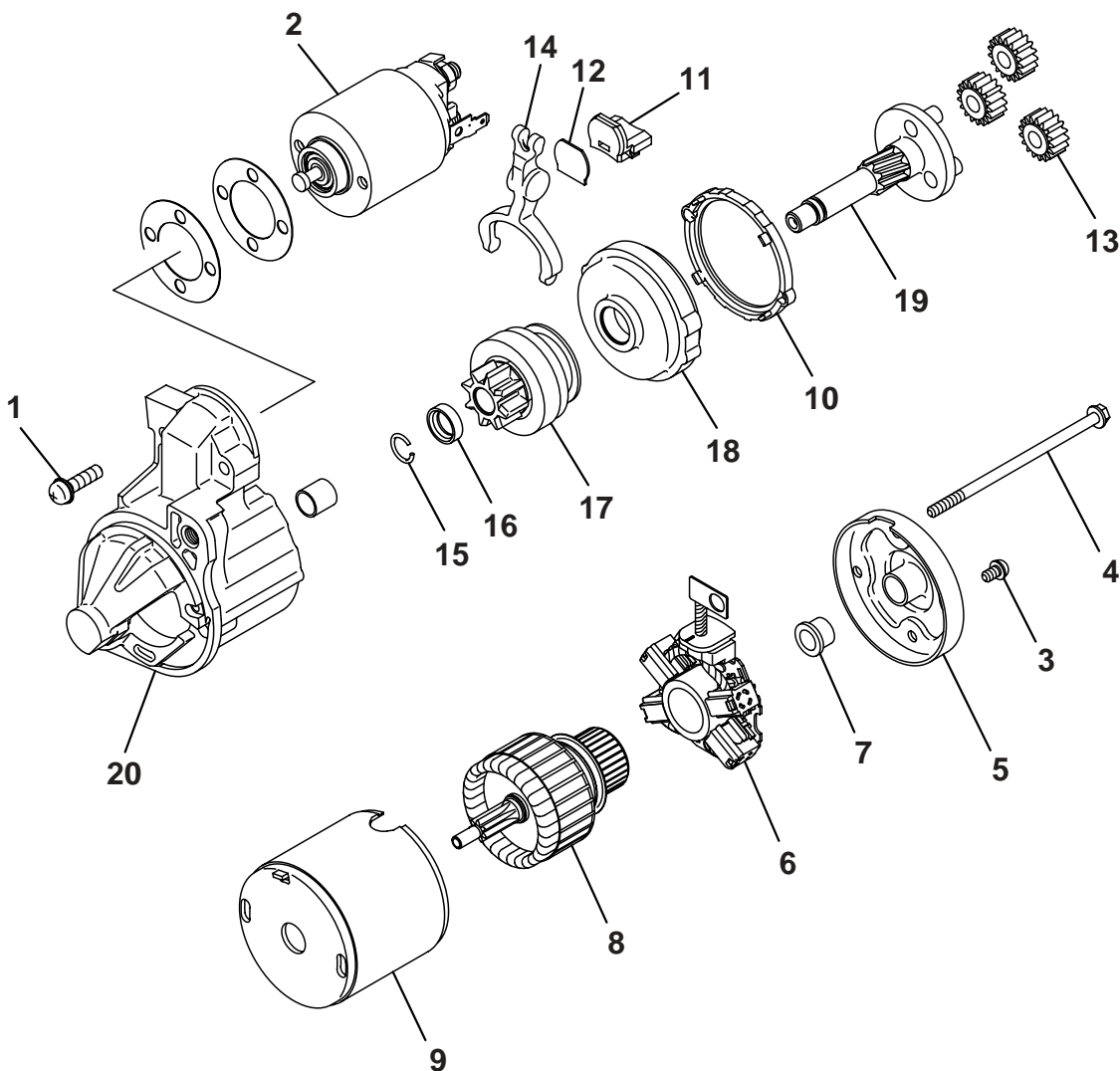

AK204335AB

DISASSEMBLY STEPS

<<A>>

1. SCREW
2. MAGNETIC SWITCH
3. SCREW
4. BOLT
5. REAR BRACKET
6. BRUSH HOLDER
7. REAR BEARING
8. ARMATURE
9. YOKE ASSEMBLY
10. PACKING A

DISASSEMBLY STEPS (Continued)

11. PACKING B
 12. PLATE
 13. PLANETARY GEAR
 14. LEVER
 15. SNAP RING
 16. STOP RING
 17. OVERRUNNING CLUTCH
 18. INTERNAL GEAR
 19. PLANETARY GEAR SHAFT
 20. FRONT BRACKET
- <> >>A<<
<> >>A<<

DISASSEMBLY SERVICE POINTS**<<A>> MAGNETIC SWITCH REMOVAL****⚠ CAUTION**

Do not clamp the yoke assembly with a vise.

Disconnect the lead from the M terminal of the magnetic switch.

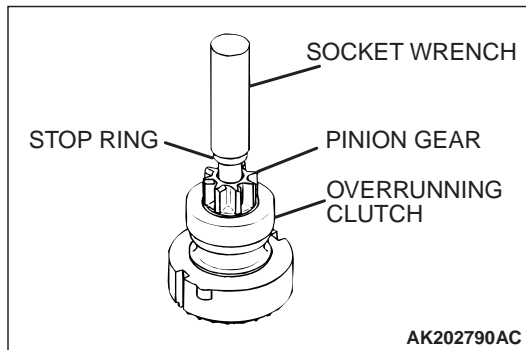
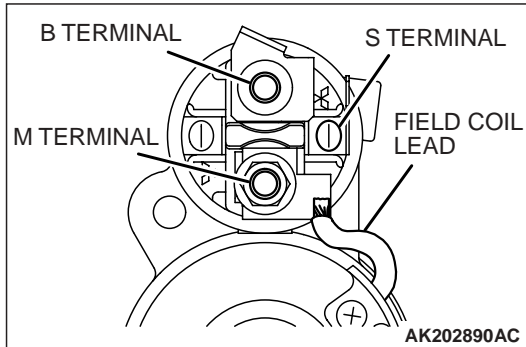
**<> SNAP RING/STOP RING REMOVAL**

1. Apply a long socket wrench of an appropriate size to the stop ring and strike the wrench to drive out the stop ring toward the pinion gear side.

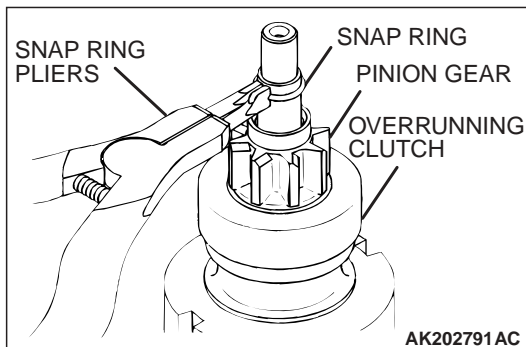

2. Remove the snap ring with snap ring pliers, then remove the stop ring and overrunning clutch.

STARTER MOTOR PARTS CLEANING

1. Never clean in a solvent such starter motor parts as the magnetic switch, brush holder, and armature. If they are soaked in a solvent, their insulation could be impaired. When these parts require cleaning, wipe off contamination with cloth.
2. Never soak the drive unit in a solvent. If it is washed in a solvent, the grease having been packed in the overrunning clutch at the factory will be washed out. Wipe the drive unit with cloth if it requires cleaning.

REASSEMBLY SERVICE POINTS

>>A<< STOP RING/SNAP RING INSTALLATION

Use a suitable puller to pull the stop ring until it gets over the snap ring.

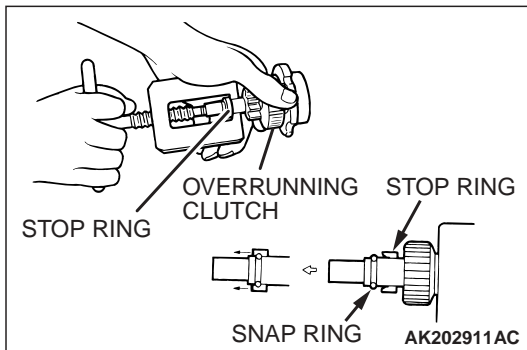

INSPECTION (DISASSEMBLY AND ASSEMBLY)

M1162001300124

COMMUTATOR

1. Support the armature with a pair of V block and turn it to measure the runout of the surface not rubbed by the brushes using a dial gauge.

Standard value: 0.05 mm or less

Limit: 0.1 mm

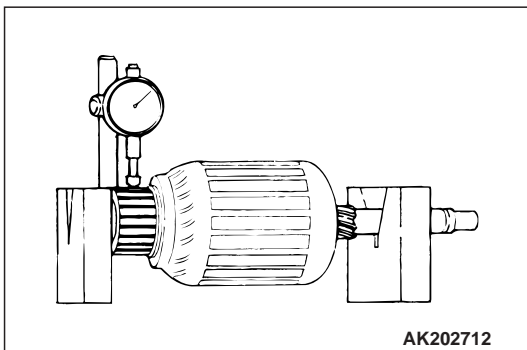

2. Measure the diameter of the commutator.

Standard value: 29.4 mm

Limit: 28.8 mm

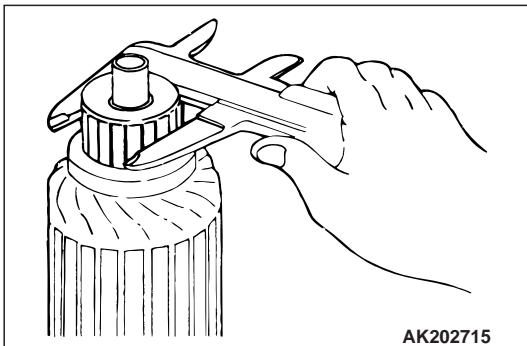

3. Measure the depth of the undercut between segments.

Standard value: 0.5 mm

Limit: 0.2 mm

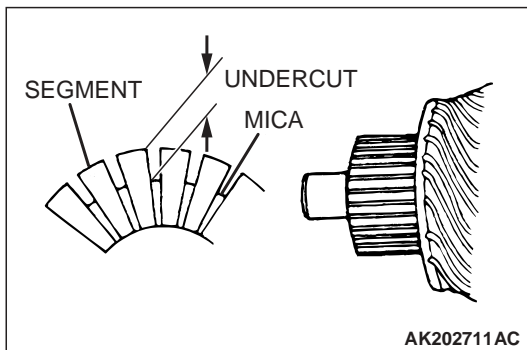

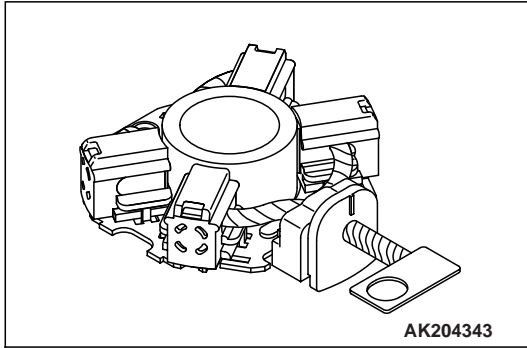
**BRUSH HOLDER**

Push the brush into the brush holder to make sure that the spring is working on the brush.

If the spring is not working, replace the brush holder.

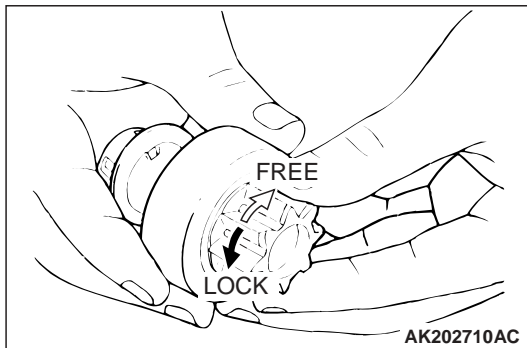
**OVERRUNNING CLUTCH**

1. Make sure that the pinion cannot be turned counterclockwise and can be turned clockwise freely.
2. Check the pinion for abnormal wear and damage.

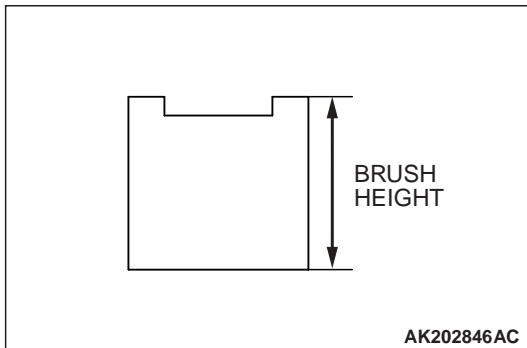
**BRUSHES**

1. Check the commutator contacting surface of each brush for abnormal roughness. Also check the height of the brush. Replace the brush holder if the height is lower than the limit.

Limit: 7.0 mm

2. When the contact surface of the brush is rectified or the brush holder is replaced, recondition the contact surface with sandpaper wrapped around the commutator.

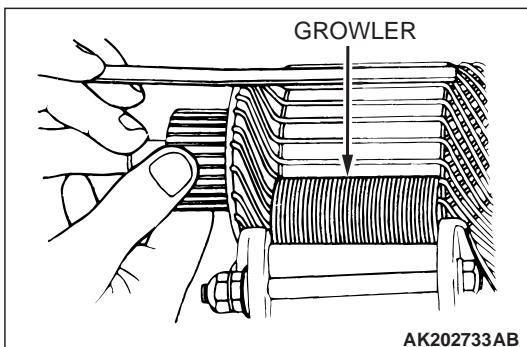
**ARMATURE COIL**

1. Check the armature coil for short circuit as follows:
2. Set the armature in a growler.

⚠ CAUTION

Clean the surface of the armature thoroughly before performing the test.

3. While holding a thin strip of iron against the armature in parallel with its axis, turn the armature slowly. The armature is normal if the iron strip is not attracted to the armature or it does not vibrate.

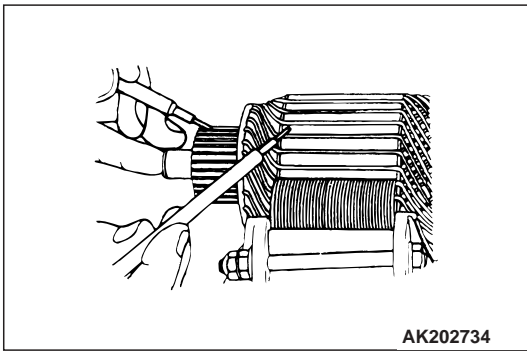

4. Check the insulation between commutator segments and armature coils. The armature coils are properly insulated if no continuity is present.

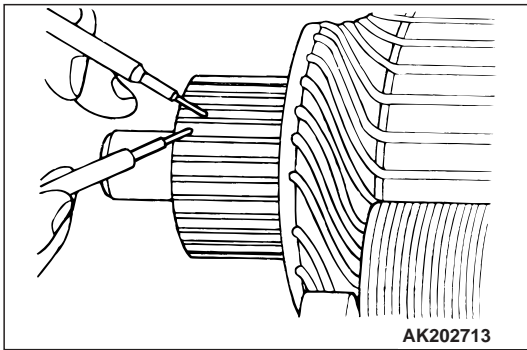

5. Check continuity between a segment and another. There is no open circuit in the tested coil if there is continuity.

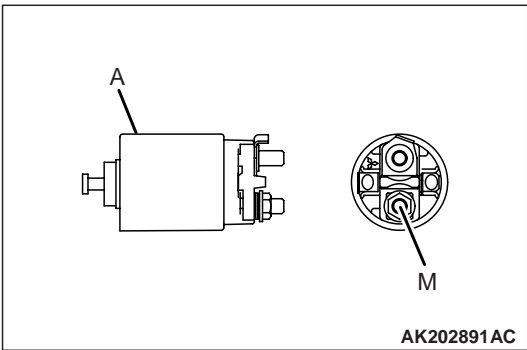

MAGNETIC SWITCH

1. Coil open circuit test
 - Check that there is continuity between the M terminal and body A.
 - If there is no continuity, replace the magnetic switch.

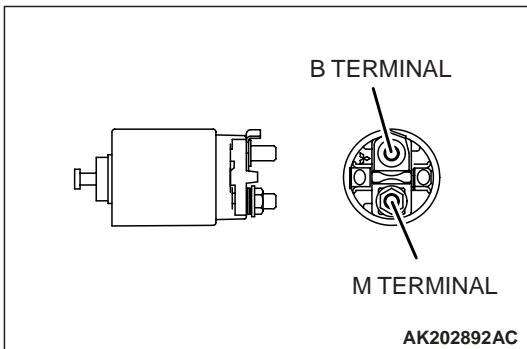

2. Contact fusion check
 - Check that there is no continuity between the B terminal and M terminal.
 - If there is continuity, replace the magnetic switch.

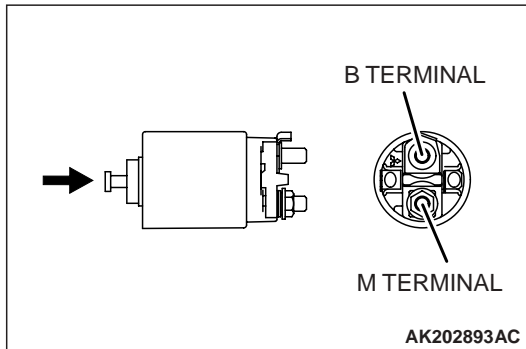

3. Switch contact check

- Push the indicated end of the magnetic switch with a strong force to close the internal contacts. Without releasing the switch end, check that there is continuity between the B terminal and M terminal.
- If there is no continuity, replace the magnetic switch.

IGNITION SYSTEM

GENERAL DESCRIPTION

This system is provided with two ignition coils (A and B) with built-in ignition power transistors for the number 1 and number 4 cylinders, and number 2 and number 3 cylinders respectively.

Interruption of the current flowing in the primary side of ignition coil A generates a high voltage in the secondary side of ignition coil A.

The high voltage generated is applied to the spark plugs of number 1 and number 4 cylinders to generate sparks. At the time that the sparks are generated at both spark plugs, if one cylinder is at the compression stroke, the other cylinder is at the exhaust stroke, so that ignition of the compressed air/fuel mixture occurs only for the cylinder which is on the compression stroke.

In the same way, when the primary current flowing in ignition coil B is interrupted, the high voltage thus generated is applied to the spark plugs of number 2 and number 3 cylinders.

M1163000100227

The engine control module controls the two ignition power transistors to turn them alternately ON and OFF. This causes the primary currents in the ignition coils to be alternately interrupted and allowed to flow to fire the cylinders in the order 1 – 3 – 4 – 2.

The engine control module determines which ignition coil should be controlled by means of the signals from the camshaft position sensor and from the crankshaft position sensor.

It also detects the crankshaft position in order to provide ignition at the most appropriate timing in response to the engine operation conditions.

When the engine is cold or operated at high altitudes, the ignition timing is slightly advanced to provide optimum performance.

VOLUME AIRFLOW SENSOR
INTAKE AIR TEMPERATURE SENSOR
BAROMETRIC PRESSURE SENSOR
ENGINE COOLANT TEMPERATURE SENSOR
CAMSHAFT POSITION SENSOR
CRANKSHAFT POSITION SENSOR
VEHICLE SPEED SENSOR
IGNITION SWITCH-ST
KNOCK SENSOR

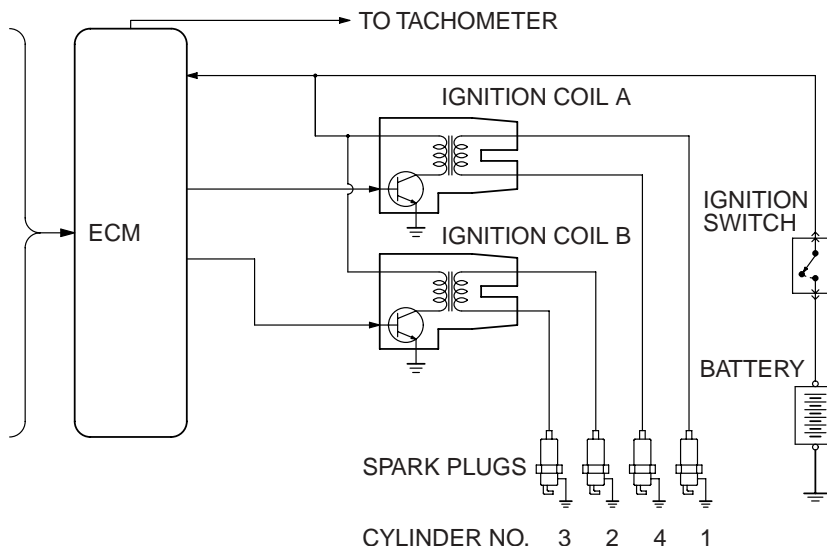

AK100055 AF

SPECIAL TOOL

M1163000600170

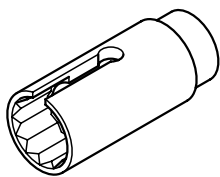
TOOL	TOOL NUMBER AND NAME	SUPERSESSION	APPLICATION
	MD998773 Knock sensor wrench	MD998773-01	Knock sensor removal and installation

ON-VEHICLE SERVICE

IGNITION COIL CHECK

M1163001200302

Check by the following procedure, and replace the coil if there is a malfunction.

SECONDARY COIL RESISTANCE CHECK

Measure the resistance between the high-voltage terminals of the ignition coil.

Standard value: 8.5 – 11.5 kΩ

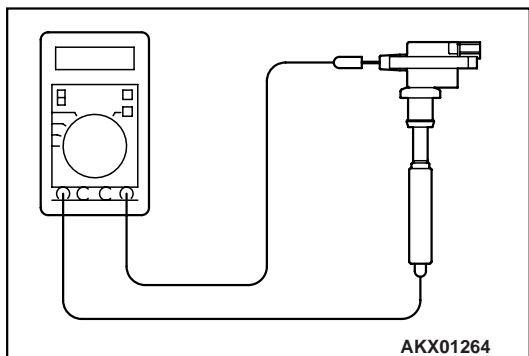

PRIMARY COIL AND IGNITION POWER TRANSISTOR CONTINUITY CHECK

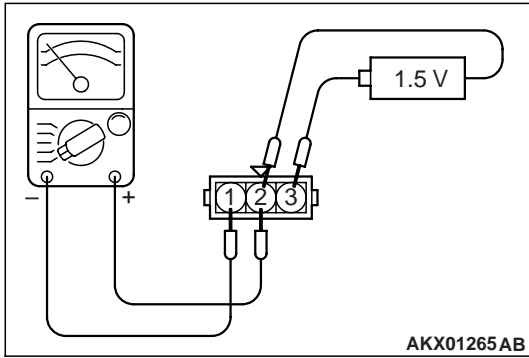

NOTE: An analog-type ohmmeter should be used.

NOTE: Connect the negative probe of the ohmmeter to terminal No. 1.

⚠ CAUTION

This test must be performed quickly (in less than 10 seconds) to prevent coil from burning and ignition power transistor from breaking.

1. Connect and disconnect 1.5 V battery between terminals No. 2 and No. 3, and observe the ohmmeter whether there is continuity or not.
2. If results do not agree with the table below, replace the primary coil and ignition power transistor assembly.

1.5 V POWER SUPPLY BETWEEN 2 – 3	CONTINUITY BETWEEN 1 – 2
Current flowing	Yes
Current not flowing	No

SPARK PLUG CABLE RESISTANCE CHECK

M1163001400072

Measure the resistance of the all spark plug leads.

1. Check the cap and coating for cracks.
2. Measure the resistance.

Limit: 19 kΩ

3. If resistance is greater than 19 kΩ, replace the cable.

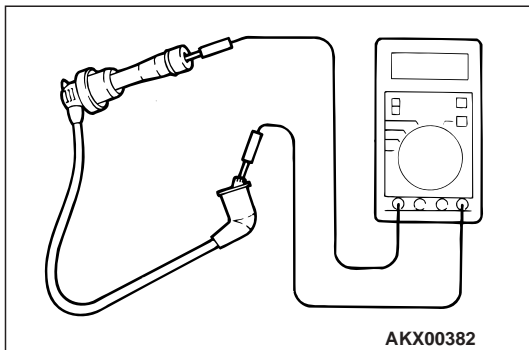

SPARK PLUG CHECK AND CLEANING

M1163004300278

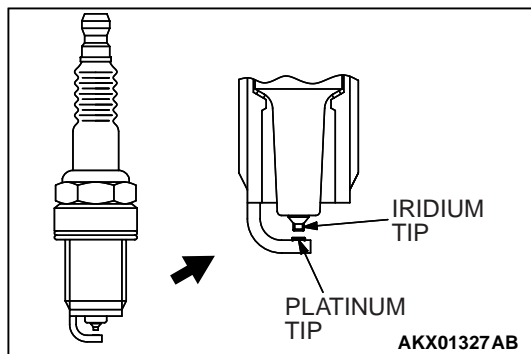

⚠ CAUTION

- Do not attempt to adjust the gap of the iridium plug.
- Cleaning of the iridium plug may result in damage to the iridium and platinum tips. Therefore, if carbon deposits must be removed, use a plug cleaner and complete cleaning within 20 seconds to protect the electrode. Do not use a wire brush.

Check the plug gap and replace if the limit is exceeded.

Standard value: 0.7 – 0.8 mm (0.028 – 0.031 inch)

Limit: 1.0 mm (0.039 inch)

CAMSHAFT POSITION SENSOR CHECK

M1163004400101

Refer to GROUP 13A, Diagnostic Trouble Code Procedures – DTC 0340: Camshaft Position Sensor Circuit [P.13A-317](#).

CRANK ANGLE SENSOR CHECK

M1163004500120

Refer to GROUP 13A, Diagnostic Trouble Code Procedures – DTC P335: Crankshaft Position Sensor Circuit [P.13A-302](#).

IGNITION SECONDARY VOLTAGE WAVE PATTERN CHECK USING AN OSCILLOSCOPE

M1163001700125

MEASUREMENT METHOD

1. Clamp the spark plug cable (Number 1 or 3) with the secondary pickup.

NOTE: Because of the two-cylinder simultaneous ignition system, the waves for two cylinders in each group appear during wave observation. However, wave observation is carried out for the cylinder (Number 1 or 3) with the spark plug cable which has been clamped by the secondary pickup.

NOTE: Identification of which cylinder wave pattern is displayed can be difficult, but the wave pattern of the cylinder which is clamped by the secondary pickup will be stable, so this can be used as a reference.

2. Clamp the spark plug cable (Number 1 or 3) with the trigger pickup.

NOTE: Clamp the same spark plug cable as the one which has been clamped by the secondary pickup.

STANDARD WAVE PATTERN

SETTINGS	
FUNCTION	SECONDARY
Pattern height	High (or low)
Pattern selector	Raster
Engine speed	Curb idle speed

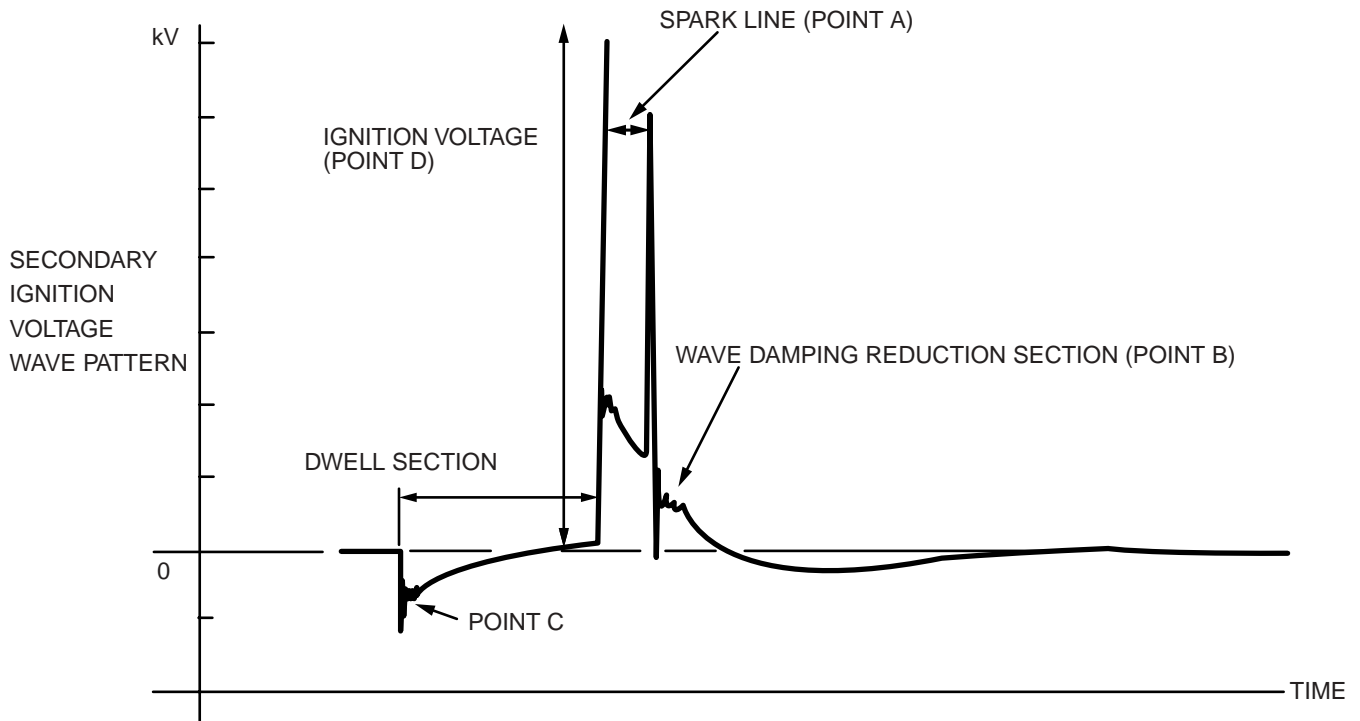

AKX00278AB

SETTINGS	
Pattern selector	Display
Pattern height	High (or low)
Engine speed	Curb idle speed

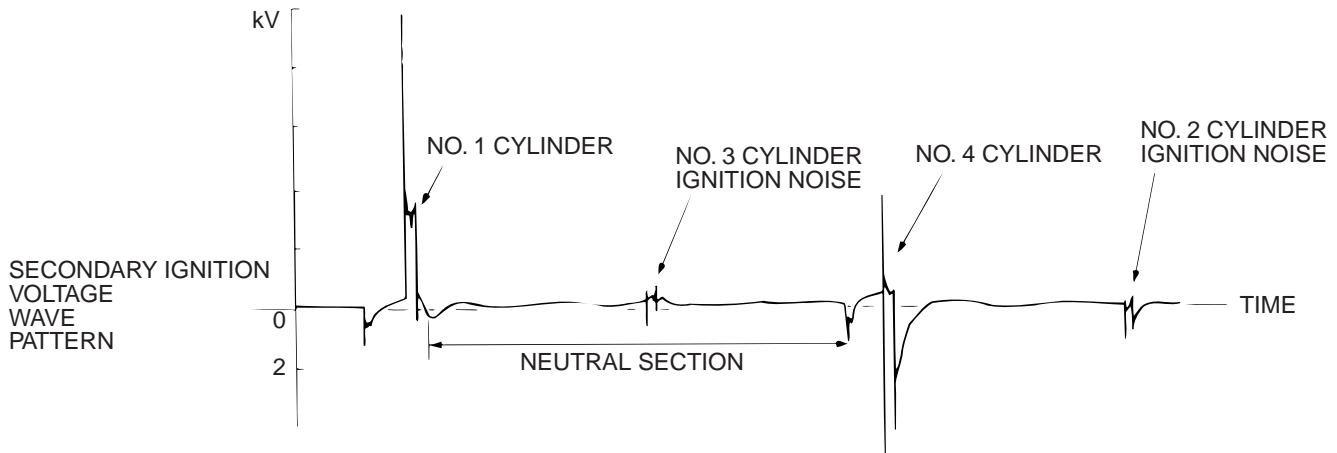

AKX01275AB

ABNORMAL WAVEFORMS EXAMPLES

Example 1

- Wave characteristics
Spark line is high and short.
- Cause of problem
Spark plug gap is too large.

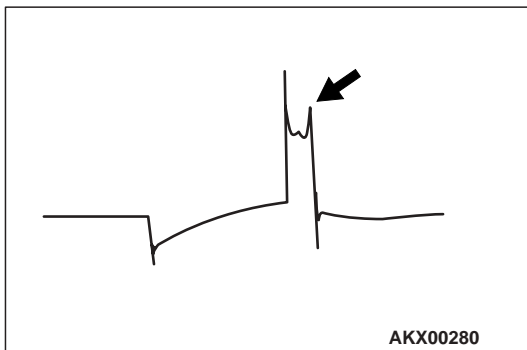

Example 2

- Wave characteristics
Spark line is low and long, and is sloping. Also, the second half of the spark line is distorted. This could be a result of misfiring.
- Cause of problem
Spark plug gap is too small.

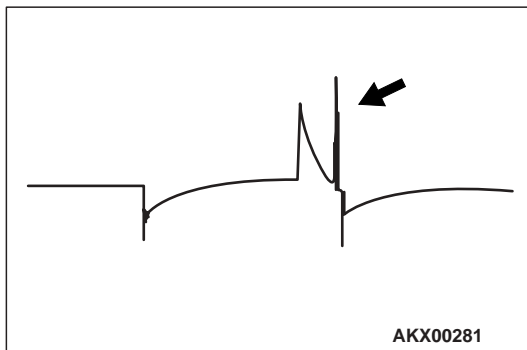

Example 3

- Wave characteristics
Spark line is low and long, and is sloping. However, there is almost no spark line distortion.
- Cause of problem
Spark plug gap is fouled.

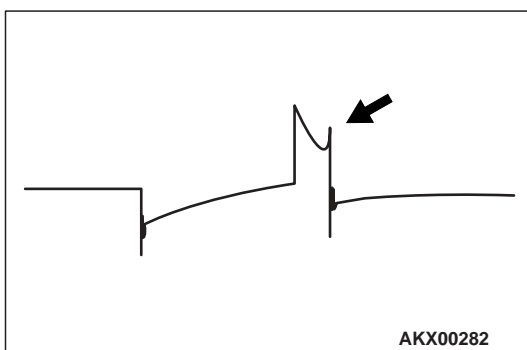

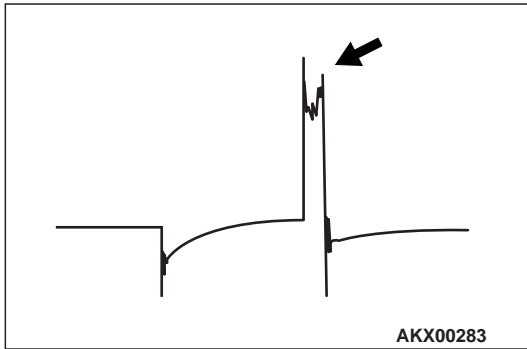
**Example 4**

- Wave characteristics
Spark line is high and short. Difficult to distinguish between this and abnormal wave pattern example 1.
- Cause of problem
Spark plug cable is not properly connected. (Causing a dual ignition)

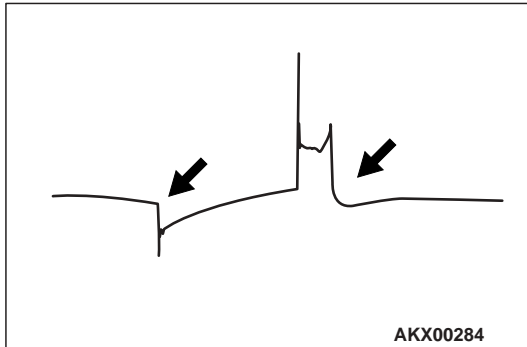
**Example 5**

- Wave characteristics
No waves in wave damping section
- Cause of problem
Short in ignition coil.

IGNITION COIL

REMOVAL AND INSTALLATION

M1163004000352

Pre-removal and Post-installation Operation

- Center Cover Removal and Installation (Refer to GROUP 11A, Camshaft and Valve Stem Seal P.11A-28).

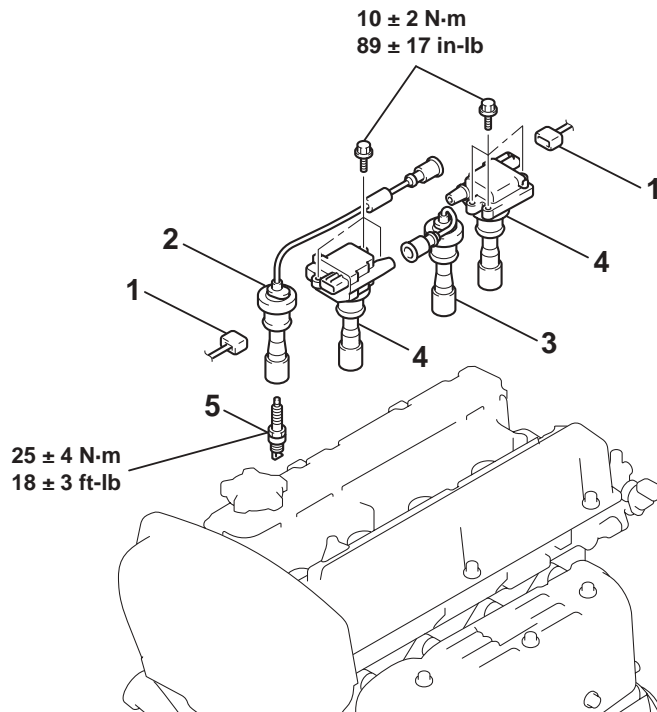

REMOVAL STEPS

- IGNITION COIL CONNECTOR
- SPARK PLUG CABLE NUMBER 1
- SPARK PLUG CABLE NUMBER 3

AC210297AB
REMOVAL STEPS (Continued)

- IGNITION COIL
- SPARK PLUG

CAMSHAFT POSITION SENSOR

REMOVAL AND INSTALLATION

M1163003400391

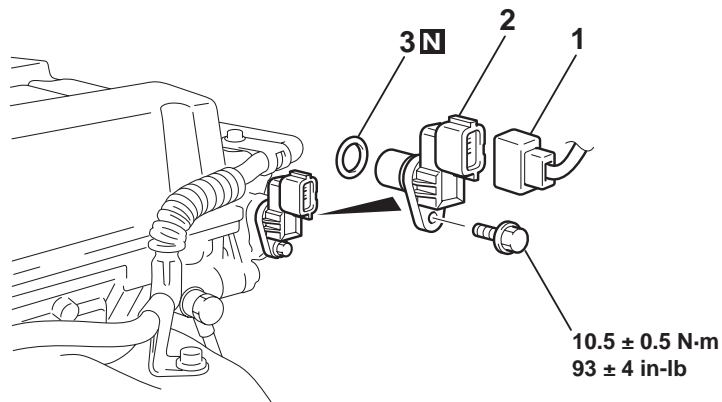

REMOVAL STEPS

- CAMSHAFT POSITION SENSOR CONNECTOR

AC210298AB
REMOVAL STEPS (Continued)

- CAMSHAFT POSITION SENSOR
- O-RING

CRANKSHAFT POSITION SENSOR

REMOVAL AND INSTALLATION

M1163003500376

CAUTION

If the vehicle is equipped with the Brembo disc brake, during maintenance, take care not to contact the parts or tools to the caliper because the paint of caliper will be scratched.

Pre-removal and Post-installation Operation

- Timing Belt Removal and Installation (Refer to GROUP 11A, Timing Belt P.11A-50).
- Radiator Reserve Tank Assembly Removal and Installation (Refer to GROUP 14, Radiator P.14-22).

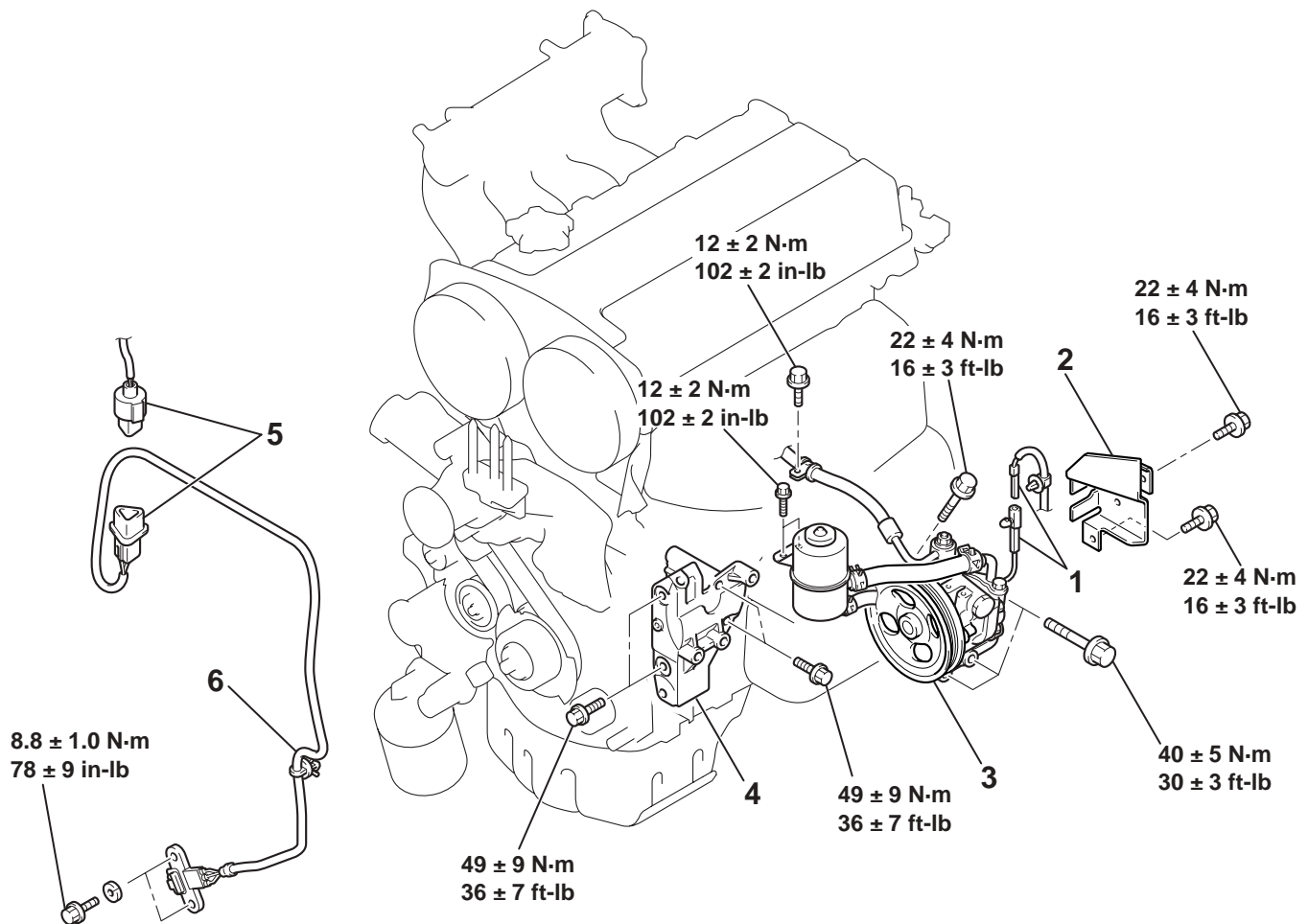

AC210409AB

REMOVAL STEPS

1. POWER STEERING PRESSURE SWITCH CONNECTOR
2. POWER STEERING OIL PUMP HEAT PROTECTOR
3. POWER STEERING OIL PUMP, BRACKET AND OIL RESERVOIR ASSEMBLY

REMOVAL STEPS (Continued)

4. POWER STEERING OIL PUMP BRACKET
5. CRANKSHAFT POSITION SENSOR CONNECTOR
6. CRANKSHAFT POSITION SENSOR

<<A>>

REMOVAL SERVICE POINT

<<A>> POWER STEERING OIL PUMP, BRACKET AND OIL RESERVOIR ASSEMBLY REMOVAL

NOTE: Tie the removed power steering oil pump, bracket and oil reservoir assembly with a rope and set aside where they cannot hinder the removal of the power steering oil pump bracket.

Remove the power steering oil pump, bracket and oil reservoir assembly with the hoses attached from the power steering oil pump bracket.

KNOCK SENSOR

REMOVAL AND INSTALLATION

M1163002800426

Pre-removal and Post-installation Operation

- Intake Manifold Stay Removal and Installation (Refer to GROUP 15, Intake Manifold P.15-13).

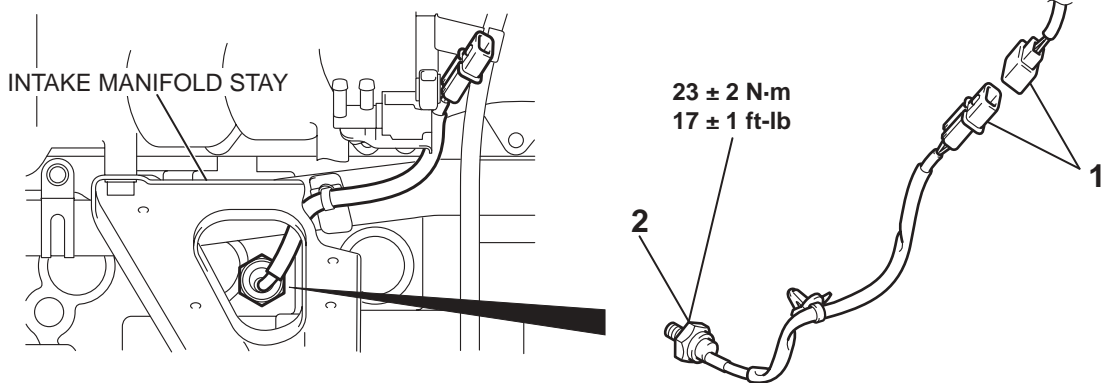

AC210411AB

REMOVAL

- <<A>> >>A<<
1. KNOCK SENSOR CONNECTOR
 2. KNOCK SENSOR

Required Special Tool:

- MD998773: Knock sensor wrench

REMOVAL SERVICE POINT

<<A>> KNOCK SENSOR REMOVAL

Use special tool MD998773 to remove the knock sensor.

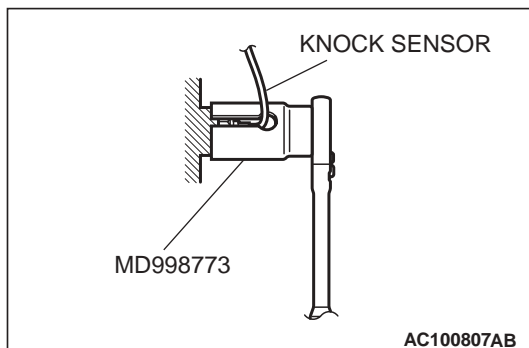

AC100807AB

INSTALLATION SERVICE POINT

>>A<< KNOCK SENSOR INSTALLATION

Use special tool MD998773 to install the knock sensor.

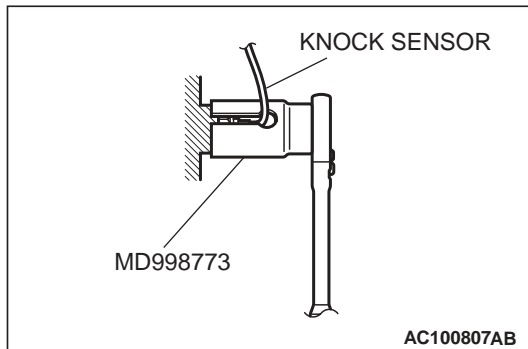

SPECIFICATIONS

FASTENER TIGHTENING SPECIFICATIONS

M1161002100487

ITEM	SPECIFICATION
Charging system	
Evaporative emission purge solenoid bolt	9.0 ± 1.0 N·m (80 ± 9 in-lb)
Fuel pressure solenoid bolt	9.0 ± 1.0 N·m (80 ± 9 in-lb)
Fuel rail bolt	11 ± 1 N·m (98 ± 8 in-lb)
Generator bolt	22 ± 4 N·m (16 ± 3 ft-lb)
Generator brace bolt (water pump bolt)	23 ± 3 N·m (17 ± 2 ft-lb)
Generator brace bolt	22 ± 4 N·m (16 ± 3 ft-lb)
Generator brace stay bolt (intake manifold bolt)	20 ± 2 N·m (15 ± 1 ft-lb)
Generator brace stay nut (intake manifold nut)	36 ± 6 N·m (27 ± 4 ft-lb)
Generator nut	44 ± 10 N·m (33 ± 7 ft-lb)
Generator terminal nut	14 ± 3 N·m (124 ± 26 in-lb)
Ground cable bolt	5.0 ± 1.0 N·m (44 ± 9 in-lb)
Oil level gauge guide bolt	13 ± 1 N·m (115 ± 9 in-lb)
Water pump pulley bolt	8.8 ± 1.0 N·m (78 ± 9 in-lb)
Starting system	
Starter bolt	30 ± 3 N·m (23 ± 2 ft-lb)
Starter cover bolt	4.9 ± 1.0 N·m (44 ± 8 in-lb)
Starter cover nut	4.9 ± 1.0 N·m (44 ± 8 in-lb)
Starter terminal nut	13 ± 2 N·m (111 ± 22 in-lb)
Ignition system	
Camshaft position sensor bolt	10.5 ± 0.5 N·m (93 ± 4 in-lb)
Crankshaft position sensor bolt	8.8 ± 1.0 N·m (78 ± 9 in-lb)
Ignition coil bolt	10 ± 2 N·m (89 ± 17 in-lb)
Knock sensor	23 ± 2 N·m (17 ± 1 ft-lb)
Power steering oil pressure hose bolt	12 ± 2 N·m (102 ± 2 in-lb)

ITEM	SPECIFICATION	
Power steering oil pump bracket bolt (cylinder block side)	49 ± 9 N·m (36 ± 7 in-lb)	
Power steering oil pump bracket bolt (power steering oil pump side)	M8	22 ± 4 N·m (16 ± 3 ft-lb)
	M10	40 ± 5 N·m (30 ± 3 ft-lb)
Power steering oil pump heat protector bolt	22 ± 4 N·m (16 ± 3 in-lb)	
Power steering oil reservoir bolt	12 ± 2 N·m (102 ± 2 in-lb)	
Spark plug	25 ± 4 N·m (18 ± 3 ft-lb)	

GENERAL SPECIFICATIONS

M1161000200239

ITEMS	SPECIFICATIONS
Generator	
Type	Positive battery positive voltage sensing
Identification number	A3TB1791
Part No.	MD366831
Rated output V/A	12/90
Voltage regulator	Electronic built-in type
Starter motor	
Type	Reduction drive with planetary gear
Identification number	M0T31171
Part No.	MN128202
Rated output kW/V	1.2/12
Number of pinion teeth	8
Ignition coil	
Type	Molded 2-coil
Spark plugs	
NGK	IGR7A-G
DENSO	–
CHAMPION	–

SERVICE SPECIFICATIONS

M1161000300281

ITEMS	STANDARD VALUE	LIMIT
Generator		
Regulated voltage (Ambient temperature at voltage regulator)	–20°C (–4°F)	14.2 – 15.4
	20°C (68°F)	13.9 – 14.9
	60°C (140°F)	13.4 – 14.5
	80°C (176°F)	13.1 – 14.5
Generator output line voltage drop (at 30A) V	–	Maximum 0.3
Output current	–	70% of normal output current
Field coil resistance Ω	Approximately 2 – 5	–
Brush protrusion length mm (in)	–	Minimum 2 (0.08)

ITEMS		STANDARD VALUE	LIMIT
Starter motor			
Free running characteristics	Terminal voltage V	11	–
	Current A	95	–
	Speed r/min	2,500 or more	–
Pinion gap mm (in)		0.5 – 2.0 (0.02 – 0.07)	–
Commutator run-out mm (in)		0.05 (0.002)	Minimum 0.1 (0.004)
Commutator diameter mm (in)		29.4 (1.16)	Minimum 28.8 (1.13)
Undercut depth mm (in)		0.5 (0.02)	Minimum 0.2 (0.008)
Ignition parts			
Ignition secondary coil resistance at 20°C (68°F) kΩ		8.5 – 11.5	–
Spark plug gap mm (in)		1.0 – 1.1 (0.039 – 0.043)	–
Resistor wire resistance kΩ		–	Maximum 19