

GROUP 42

BODY

CONTENTS

HOOD	42-4	WINDOW GLASS	42-12
BODY DIAGNOSIS	42-4	GENERAL	42-12
INTRODUCTION TO HOOD DIAGNOSIS	42-4	WINDOW GLASS DIAGNOSIS ...	42-13
HOOD DIAGNOSTIC TROUBLESHOOTING		INTRODUCTION TO WINDOW GLASS	
STRATEGY	42-4	DIAGNOSIS	42-13
SYMPTOM CHART	42-4	WINDOW GLASS DIAGNOSTIC	
SYMPTOM PROCEDURES	42-4	TROUBLESHOOTING STRATEGY.....	42-14
ON-VEHICLE SERVICE	42-6	WINDOW GLASS DIAGNOSTIC TROUBLE	
ADJUSTMENT OF CLEARANCE AROUND		SYMPTOM CHART	42-14
HOOD	42-6	SYMPTOM PROCEDURES	42-14
ADJUSTMENT OF ALIGNMENT OF		SPECIAL TOOLS	42-14
HOOD STEPPED PORTION AND HOOD		WINDSHIELD	42-15
STRIKER	42-6	REMOVAL AND INSTALLATION.....	42-15
ADJUSTMENT OF HOOD HEIGHT ...	42-6	REAR WINDOW GLASS	42-20
HOOD	42-7	REMOVAL AND INSTALLATION.....	42-20
REMOVAL AND INSTALLATION	42-7	DOOR	42-23
FENDER	42-8	GENERAL DESCRIPTION	42-23
SPECIAL TOOL	42-8	CENTRAL DOOR LOCKING SYSTEM	
FENDER	42-9	DIAGNOSIS	42-23
REMOVAL AND INSTALLATION	42-9	POWER WINDOW DIAGNOSIS	42-23
FUEL FILLER LID	42-11	DOOR DIAGNOSIS	42-23
REMOVAL AND INSTALLATION	42-11	INTRODUCTION TO GLASS AND DOOR	
STRUT TOWER BAR	42-12	DIAGNOSIS	42-23
REMOVAL AND INSTALLATION	42-12	GLASS AND DOOR DIAGNOSTIC	
		TROUBLESHOOTING STRATEGY.....	42-23
		SYMPTOM CHART	42-24
		SYMPTOM PROCEDURES	42-24
		HOW TO LOCATE WIND NOISE.....	42-27
		SPECIAL TOOLS	42-28

Continued on next page

ON-VEHICLE SERVICE	42-29	ON-VEHICLE SERVICE	42-49
DOOR FIT ADJUSTMENT	42-29	TRUNK LID ADJUSTMENT	42-49
DOOR WINDOW GLASS ADJUSTMENT	42-30	ADJUSTMENT OF CLEARANCE	
GLASS SLIDING MECHANISM CHECK		AROUND TRUNK LID	42-50
AND ADJUSTMENT	42-31	TRUNK LID STRIKER ADJUSTMENT..	42-50
POWER WINDOW TIMER FUNCTION		TRUNK LID HEIGHT ADJUSTMENT...	42-50
CHECK	42-31		
POWER WINDOW OPERATING CURRENT		TRUNK LID	42-51
CHECK	42-32	REMOVAL AND INSTALLATION	42-51
POWER WINDOW RELAY CHECK ...	42-32	INSPECTION	42-54
CIRCUIT BREAKER (INCORPORATED			
IN THE POWER WINDOW MOTOR)		KEYLESS ENTRY SYSTEM ..	42-54
INSPECTION	42-32		
POWER WINDOW CHECK	42-33	GENERAL DESCRIPTION	42-54
CENTRAL DOOR LOCKING SYSTEM		KEYLESS ENTRY SYSTEM	
INSPECTION	42-33	DIAGNOSIS	42-54
DOOR OUTSIDE HANDLE PLAY CHECK	42-33		
DOOR INSIDE HANDLE PLAY		SPECIAL TOOLS	42-55
ADJUSTMENT	42-33		
		ON-VEHICLE SERVICE	42-55
DOOR ASSEMBLY	42-34	HOW TO REPLACE THE TRANSMITTER	
REMOVAL AND INSTALLATION	42-34	BATTERY	42-55
INSPECTION	42-35	KEYLESS ENTRY SYSTEM TIMER	
		LOCK FUNCTION INSPECTION	42-55
DOOR GLASS AND REGULATOR	42-36	ENABLING/DISABLING THE	
REMOVAL AND INSTALLATION	42-36	ANSWERBACK FUNCTION	42-55
INSPECTION	42-39	HOW TO REGISTER SECRET CODE .	42-58
DOOR HANDLE AND LATCH	42-41	SUNROOF ASSEMBLY	42-60
REMOVAL AND INSTALLATION	42-41		
INSPECTION	42-43	GENERAL DESCRIPTION	42-60
		SUNROOF DIAGNOSIS	42-60
WINDOW GLASS RUNCHANNEL		SPECIAL TOOLS	42-60
AND DOOR OPENING			
WEATHERSTRIP	42-45	ON-VEHICLE SERVICE	42-60
REMOVAL AND INSTALLATION	42-45	WATER TEST	42-60
		SUNROOF TIMER FUNCTION CHECK	42-61
TRUNK LID	42-47	SUNROOF FIT ADJUSTMENT	42-61
		SUNROOF SAFETY FUNCTION CHECK	42-61
TRUNK LID DIAGNOSIS	42-47	SUNROOF CHECK	42-61
INTRODUCTION TO TRUNK LID		ROOF LID GLASS OPERATION	
DIAGNOSIS	42-47	CURRENT CHECK	42-62
TRUNK LID DIAGNOSTIC		SUNROOF INITIALIZED ADJUSTMENT	42-62
TROUBLESHOOTING STRATEGY ...	42-47	OPERATION CHECK	42-63
SYMPTOM CHART	42-47		
SYMPTOM PROCEDURES	42-48		
SPECIAL TOOL	42-48		

Continued on next page

SUNROOF ASSEMBLY.....	42-65	SPECIFICATIONS	42-69
REMOVAL AND INSTALLATION	42-65	FASTENER TIGHTENING	
INSPECTION.....	42-67	SPECIFICATIONS	42-69
DISASSEMBLY AND ASSEMBLY.....	42-68	SERVICE SPECIFICATIONS	42-69
		SEALANT AND ADHESIVES.....	42-70
		COMPONENT IDENTIFICATIONS.	42-70

HOOD

BODY DIAGNOSIS

INTRODUCTION TO HOOD DIAGNOSIS

Wind noise at the hood may be caused by improper hood adjustment.

M1421005800341

HOOD DIAGNOSTIC TROUBLESHOOTING STRATEGY

Use these steps to plan your diagnostic strategy. If you follow them carefully, you will be sure that you have exhausted most of the possible ways to find a hood fault.

1. Gather information from the customer.

2. Verify that the condition described by the customer exists.
3. Find the malfunction by following the Symptom Chart.
4. Verify malfunction is eliminated.

M1421005900315

SYMPTOM CHART

M1421006000359

SYMPTOM	INSPECTION PROCEDURE	REFERENCE PAGE
Difficult locking and unlocking	1	P.42-4
Uneven body clearance	2	P.42-5
Uneven height	3	P.42-5

SYMPTOM PROCEDURES

INSPECTION PROCEDURE 1: Difficult Locking and Unlocking

DIAGNOSIS

STEP 1. Check the release cable routing condition.

Q: Is the release cable routed correctly?

YES : Go to Step 2.

NO : Repair the release cable, then go to Step 4.

STEP 2. Check the engagement of the hood latch and hood striker.

Q: Are the hood latch and hood striker engaged correctly?

YES : Go to Step 3.

NO : Adjust the hood latch (Refer to P.42-6).
Then go to Step 4.

STEP 3. Check for proper lubrication of release cable.

Q: Is the release cable properly lubricated?

YES : Go to Step 4.

NO : Lubricate, then go to Step 4.

STEP 4. Retest the system.

Q: Does the hood lock operate easily?

YES : The procedure is complete.

NO : Return to Step 1.

INSPECTION PROCEDURE 2: Uneven Body Clearance

DIAGNOSIS

STEP 1. Check the clearance around the hood.

Q: Are the apertures between the hood and the adjacent body panels aligned correctly?
YES : Go to Step 2.
NO : Adjust the hood (Refer to [P.42-6](#)). Then go to Step 2.

STEP 2. Retest the system.

Q: Are the clearances between body panels even?
YES : The procedure is complete.
NO : Return to Step 1.

INSPECTION PROCEDURE 3: Uneven Height

DIAGNOSIS

STEP 1. Check the hood bumper height.

Q: Is the hood bumper height proper?
YES : Go to Step 2.
NO : Adjust the hood bumper (Refer to [P.42-6](#)). Then go to Step2.

STEP 2. Retest the system.

Q: Are the hood and body height even?
YES : The procedure is complete.
NO : Return to Step 1.

ON-VEHICLE SERVICE

ADJUSTMENT OF CLEARANCE AROUND HOOD
 M1421007200088
 ADJUSTMENT OF ALIGNMENT OF HOOD
 STEPPED PORTION AND HOOD STRIKER
 M1421007300085

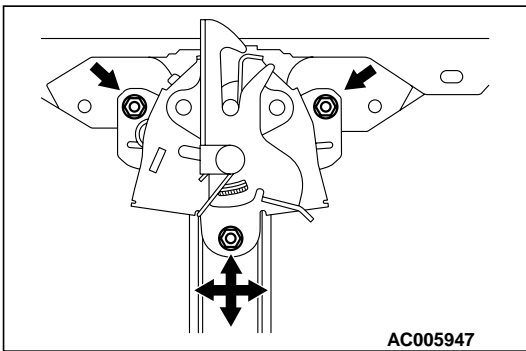
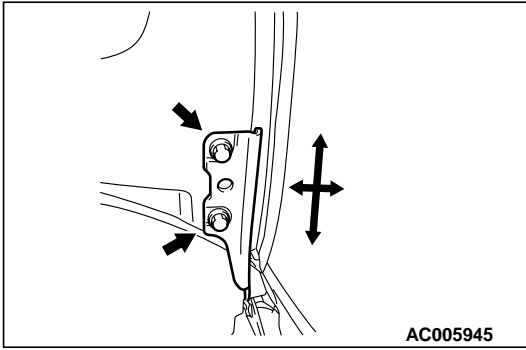

ADJUSTMENT OF HOOD HEIGHT

M1421007400082

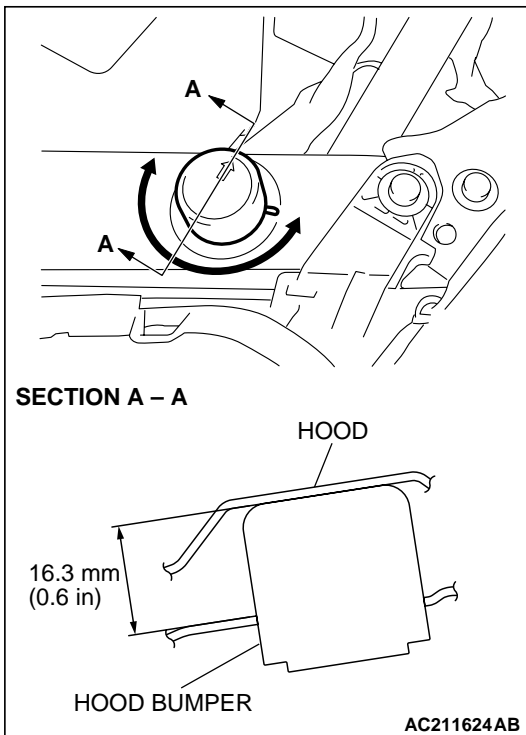

Rotate the hood bumper by using arrow mark on the hood bumper as a guide to adjust the hood height. If the hood bumper is rotated just one turn, the hood height changes by approximately 3 mm (0.1 inch).

HOOD

REMOVAL AND INSTALLATION

M1421001600271

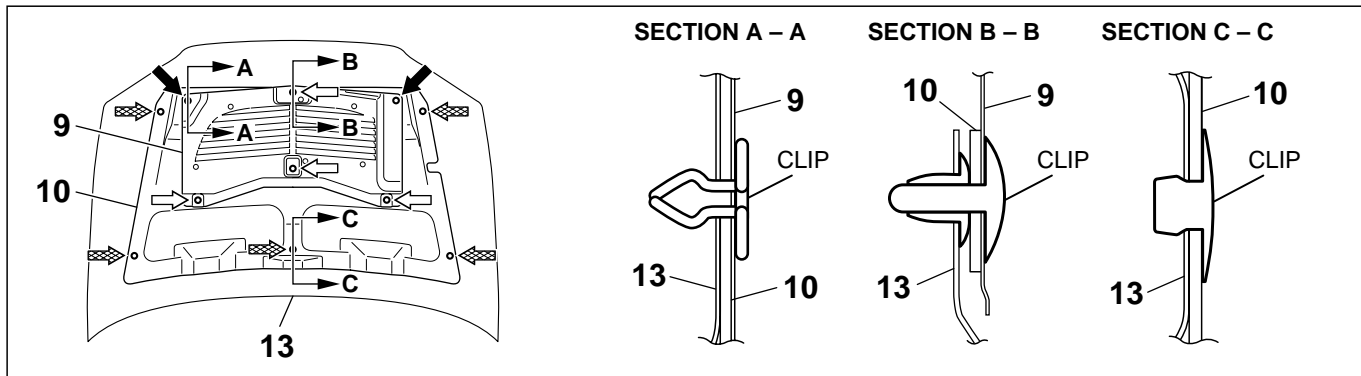

NOTE

- ← : CLIP A POSITIONS
- ⇐ : CLIP B POSITIONS
- ⊞ : CLIP C POSITIONS

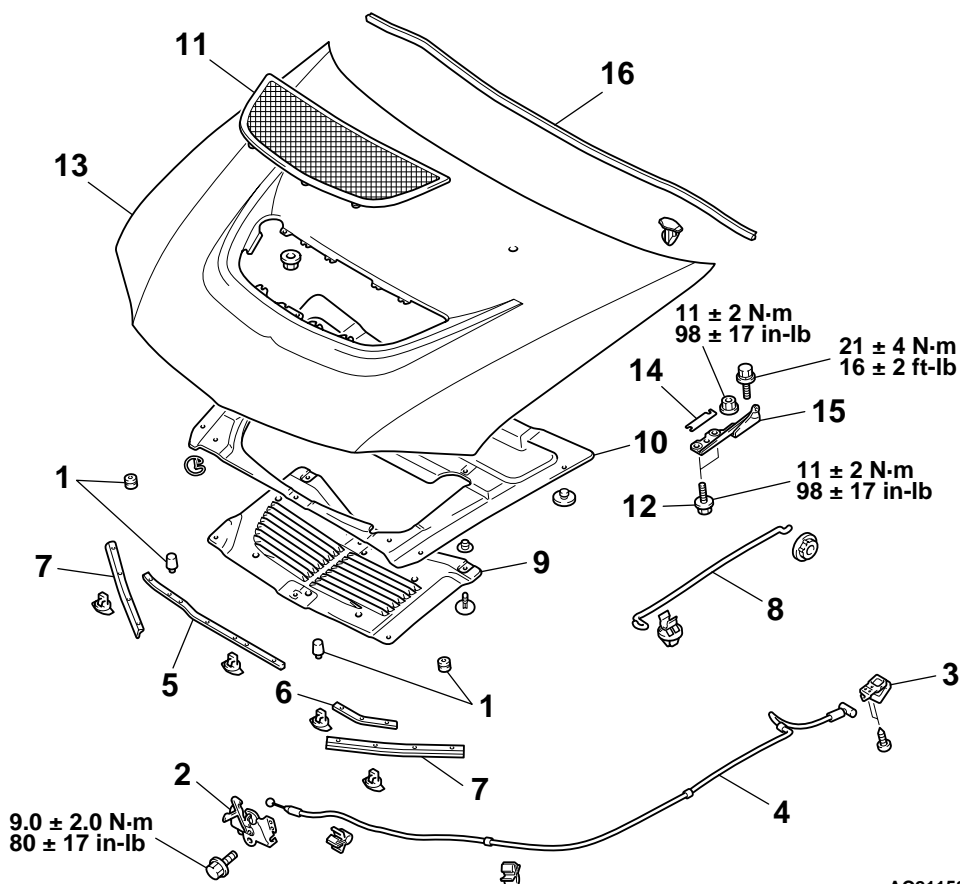
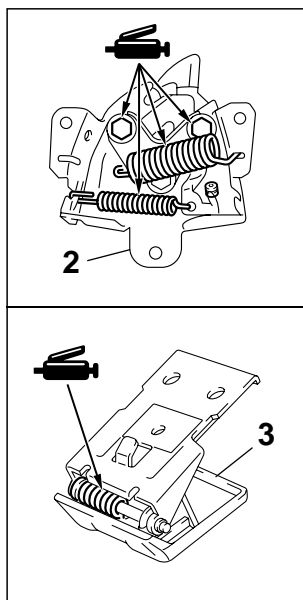

AC211580AB

REMOVAL

1. HOOD BUMPER
- HOOD LOCK RELEASE CABLE REMOVAL STEPS**
- FRONT BUMPER ASSEMBLY (REFER TO GROUP 51, FRONT BUMPER ASSEMBLY P.51-2).
 - SPLASH SHIELD (REFER TO P.42-9).
2. HOOD LATCH
 3. HOOD LOCK RELEASE HANDLE
 4. HOOD LOCK RELEASE CABLE

HOOD AND HOOD HINGE REMOVAL STEPS

5. HOOD WEATHER STRIP <RIGHT SIDE>
6. HOOD WEATHER STRIP <LEFT SIDE>
7. HEADLIGHT WEATHER STRIP
- WASHER HORSE (REFER TO GROUP 51, WINDSHIELD WASHER P.51-21).
8. HOOD SUPPORT ROD
9. HOOD HEAT PROTECTOR PANEL
10. HOOD HEAT PROTECTOR
11. HOOD OUTLET GARNISH

**HOOD AND HOOD HINGE REMOVAL
STEPS (Continued)**

- >>A<< 12. HOOD HINGE BOLT (HOOD SIDE)
13. HOOD
14. SHIM

**HOOD AND HOOD HINGE REMOVAL
STEPS (Continued)**

15. HOOD HINGE
16. HOOD WEATHER STRIP

REMOVAL SERVICE POINT

>>A<< HOOD HINGE BOLT INSTALLATION

⚠ CAUTION

Use the special parts as the aluminum hood uses special coatings on the <hood side> of the hood hinge bolt.

FENDER

SPECIAL TOOL

M1421000600182

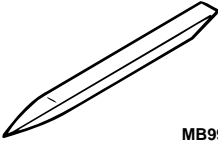
TOOL	TOOL NUMBER AND NAME	SUPERSESSSION	APPLICATION
 <p>MB990784</p>	<p>MB990784 Ornament remover</p>	<p>General service tool</p>	<p>Removal of side turn signal lamp</p>

FENDER

REMOVAL AND INSTALLATION

M1421001900261

Pre-removal and Post-installation Operation

- Front Bumper Removal and Installation (Refer to GROUP 51, Front Bumper P.51-2).
- Front Deck Garnish Removal and Installation (Refer to GROUP 51, Windshield Wiper P.51-16).

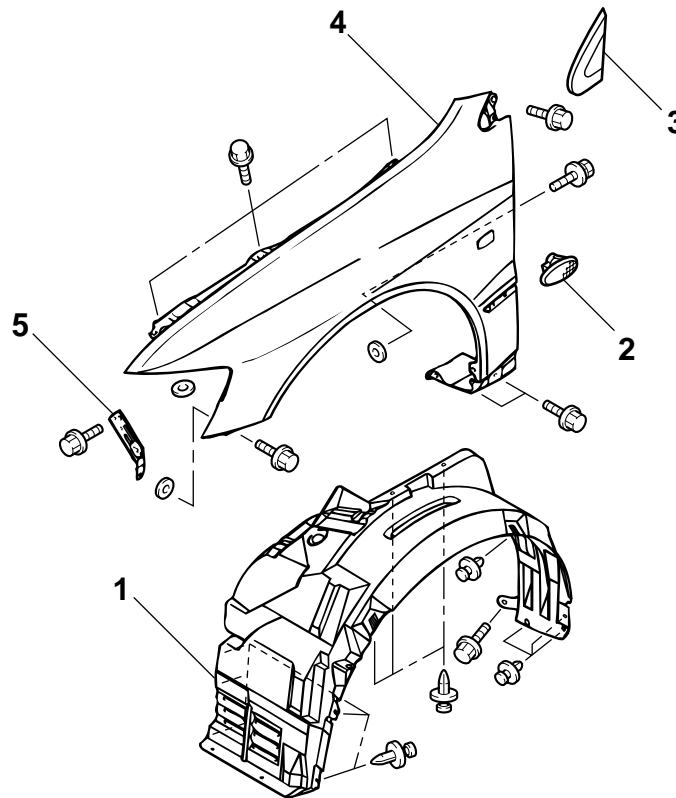

AC211637AB

REMOVAL STEPS

- SIDE AIR DAM (REFER TO GROUP 51, AIR DAM, MOLDING AND GARNISH P.51-8).
1. SPLASH SHIELD
 2. SIDE TURN SIGNAL LIGHT
 3. DELTA GARNISH (REFER TO GROUP 51, AIR DAM, MOLDING AND GARNISH P.51-8).

<<A>> >>B<<

REMOVAL STEPS (Continued)

- >>A<< 4. FENDER
5. FRONT FENDER BRACKET

Required Special Tool:

- MB990784: Ornament Remover

REMOVAL SERVICE POINT

<<A>> SIDE TURN SIGNAL LIGHT REMOVAL

Use an appropriate tool such as MB990784 to prize out the tab from the fender, and remove the side turn signal light.

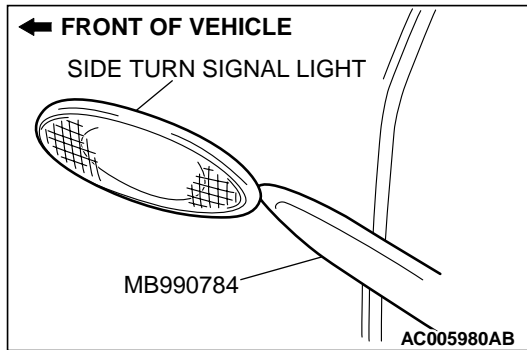

INSTALLATION SERVICE POINT

>>A<< SIDE TURN SIGNAL LIGHT INSTALLATION

CAUTION

Use the special parts as the aluminum fender uses special coatings on the fender mounting bolt and the washer.

>>B<< SIDE TURN SIGNAL LIGHT INSTALLATION

Engage the claw with the fender panel, and install the side turn signal light.

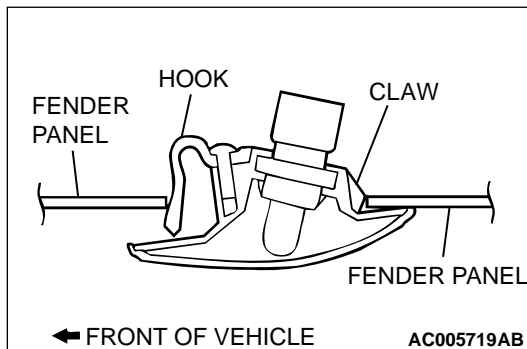

FUEL FILLER LID

REMOVAL AND INSTALLATION

M1421002500233

Pre-removal and Post-installation Operation

- Rear Seat Removal and Installation (Refer to GROUP 52A, Rear Seat P.52A-22).
- Front Scuff Plate (Driver's Seat Side), Rear Scuff Plate (Driver's Side), Center Pillar Lower Trim (Driver's Side), Quarter Trim (Driver's Side) Removal and Installation (Refer to GROUP 52A, Trims P.52A-11).

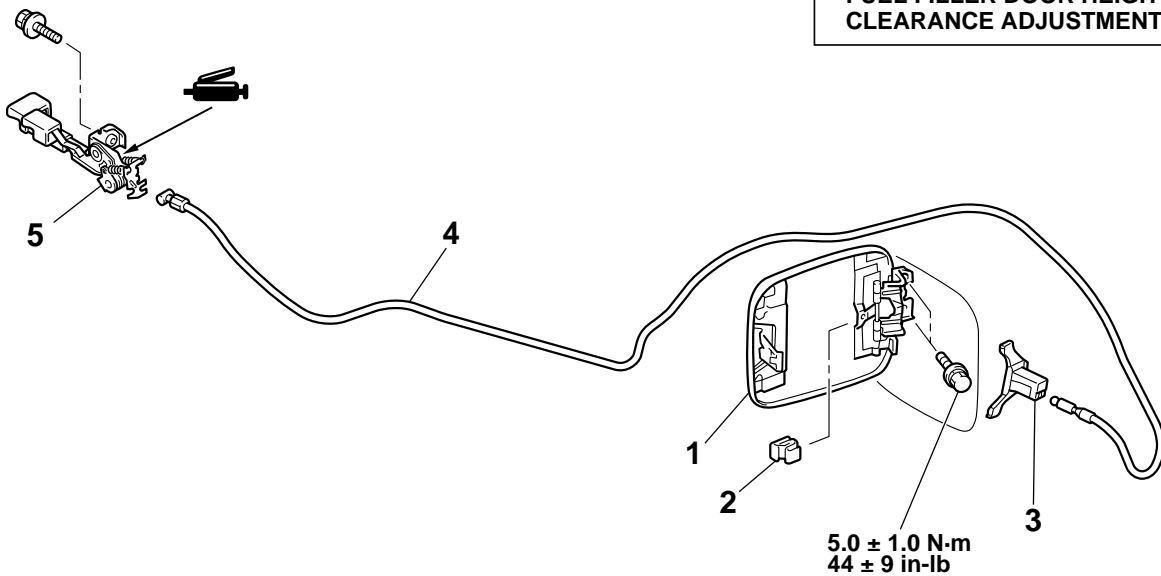
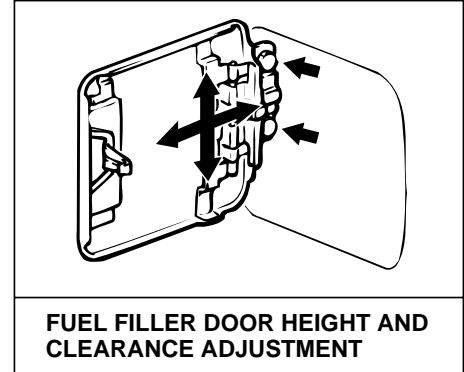
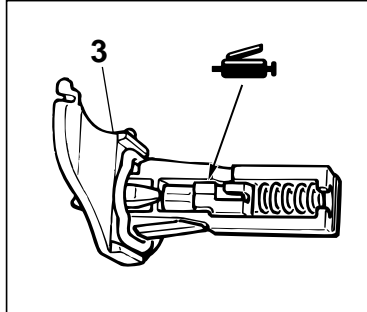

AC212370 AB

REMOVAL STEPS

1. FUEL FILLER DOOR PANEL ASSEMBLY
2. CLIP
3. FUEL FILLER DOOR HOOK ASSEMBLY

REMOVAL STEPS (Continued)

4. FUEL FILLER DOOR LOCK RELEASE CABLE
5. FUEL FILLER DOOR LOCK RELEASE HANDLE

STRUT TOWER BAR**REMOVAL AND INSTALLATION**

M1421005600080

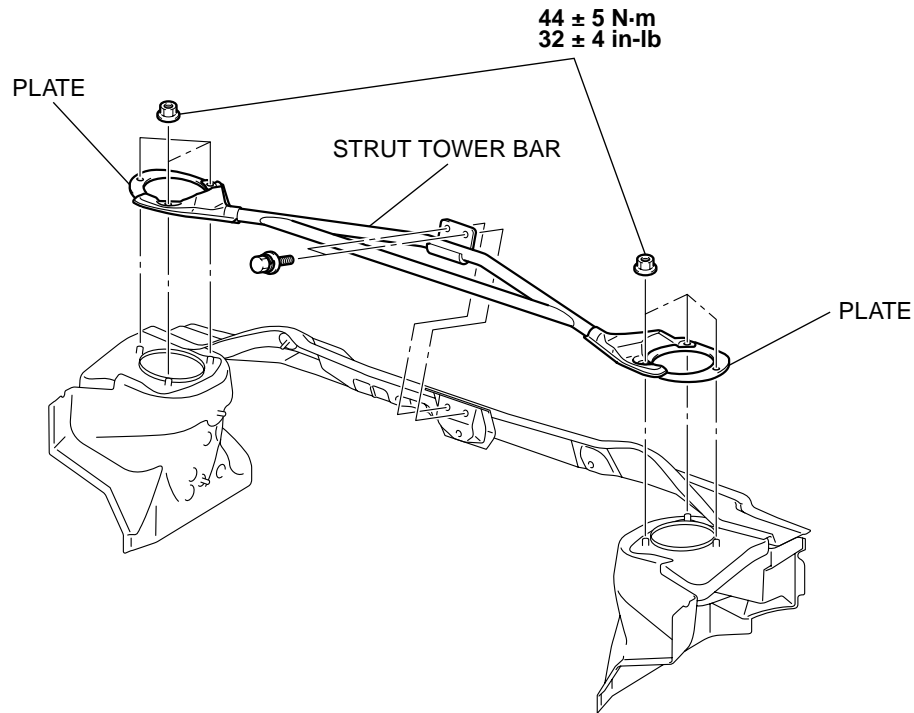

AC211421AB

WINDOW GLASS**GENERAL**

M1422000100328

The windshield and rear window glass are attached by an urethane-base adhesive to the window frame. This adhesive provides improved glass holding and sealing, and also permits use of body openings having a greater structural strength.

ITEMS

ITEM	APPLICATION	QUANTITY
Wire (dia × length)	For cutting adhesive	Five pieces of wire 0.6 mm × 1 m (0.02 in × 3.3 ft)
Glass adhesive knife	For cutting adhesive	One
Sealant gun	For adhesive application	One
Wiping shop towels	–	As required
Sealer	For prevention of water leaks and gathering after adhesive application	As required
3M AAD™ Part No. 8906 or equivalent	For cleaning	As required
Glass holder MB990480	For holding of window glass	Two
Window molding remover MB990449	For roof drip molding removal	One

WINDOW GLASS INSTALLATION

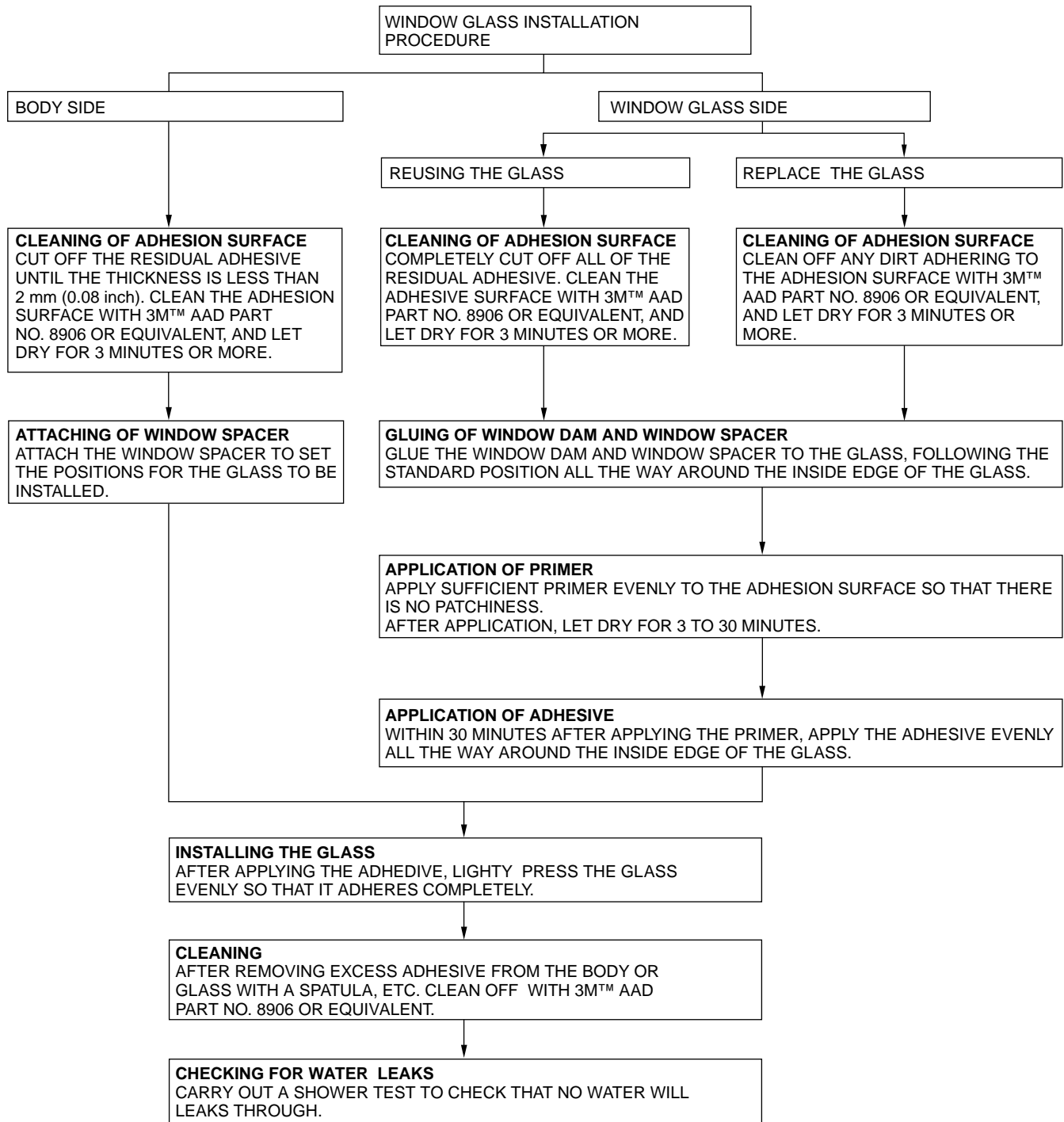

AC211513

WINDOW GLASS DIAGNOSIS

INTRODUCTION TO WINDOW GLASS DIAGNOSIS

If water leaks from the windshield, or the rear window glass, the seal or body flange may be faulty.

M1422006700243

WINDOW GLASS DIAGNOSTIC TROUBLESHOOTING STRATEGY

M1422006800239

Use these steps to plan your diagnostic strategy. If you follow them carefully, you will be sure that you have exhausted most of the possible ways to find a window glass fault.

1. Gather information from the customer.

2. Verify that the condition described by the customer exists.
3. Find the malfunction by following the Symptom Chart.
4. Verify malfunction is eliminated.

WINDOW GLASS DIAGNOSTIC TROUBLE SYMPTOM CHART

M1422006900270

SYMPTOMS	INSPECTION PROCEDURE	REFERENCE PAGE
Water leak through windshield	1	P.42-14
Water leak through rear window glass		

SYMPTOM PROCEDURES**INSPECTION PROCEDURE 1: Water Leak through Windshield/Water Leak through Rear Window Glass****DIAGNOSIS**

STEP 1. Check if the seal is faulty.

Q: Is the seal faulty?

YES : Repair the seal, then go to Step 3.

NO : Go to Step 2.

STEP 2. Check if the body flange is deformed.

Q: Is the body flange deformed?

YES : Repair the body flange, then go to Step 3.

NO : Go to Step 3.

STEP 3. Retest the system.

Q: Is any water leaking?

YES : Return to Step 1.

NO : This diagnosis complete.

SPECIAL TOOLS

M142200600259

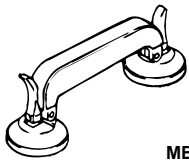
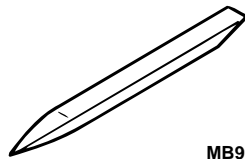
TOOL	TOOL NUMBER AND NAME	SUPERSESSON	APPLICATION
 MB990480	MB990480 Glass holder	General service tool	Removal and installation of window glass
 MB990784	MB990784 Ornament remover	General service tool	Removal of rear window lower molding

WINDSHIELD

REMOVAL AND INSTALLATION

M1422001000272

Pre-removal and Post-installation Operation

- Front Deck Garnish Removal and Installation (Refer to GROUP 51, Windshield Wiper and Washer P.51-16).
- Front Pillar Trim Removal and Installation (Refer to GROUP 52A, Trims P.52A-11).
- Headlining Removal and Installation (Refer to GROUP 52A, Headlining P.52A-18).
- Inside Rear View Mirror Removal and Installation (Refer to GROUP 52A P.52A-19).

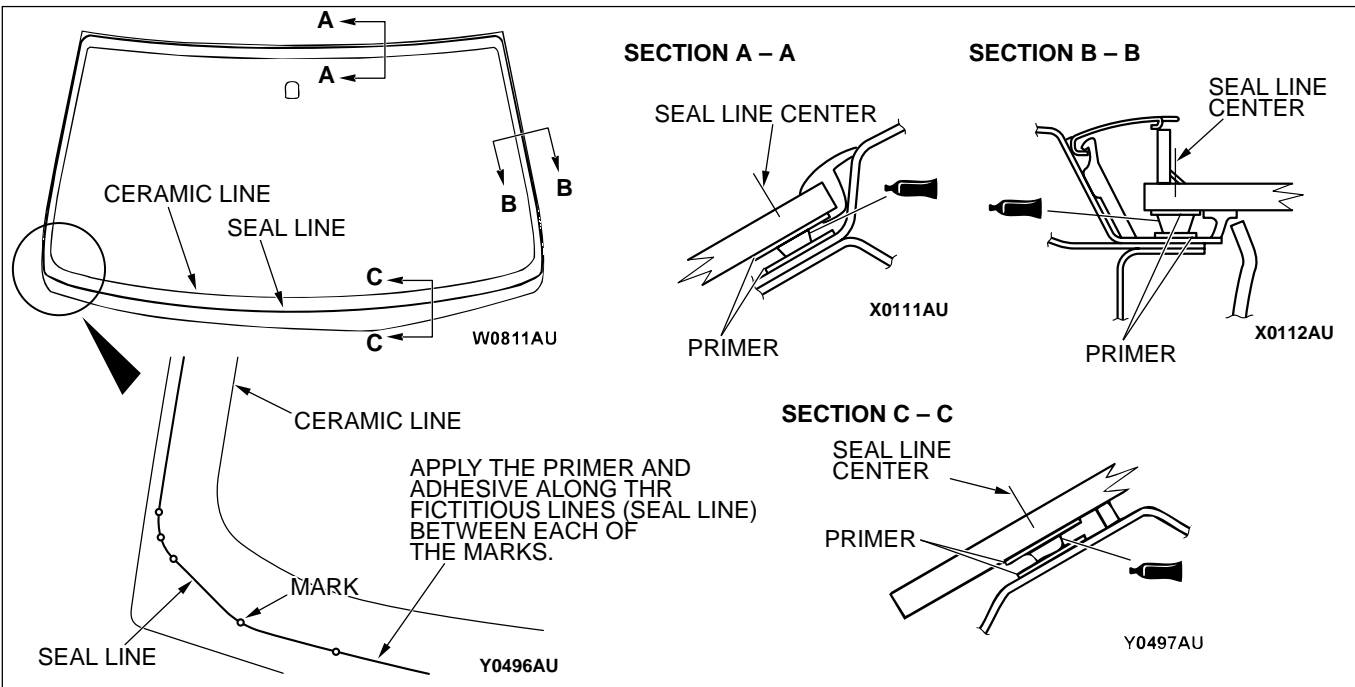
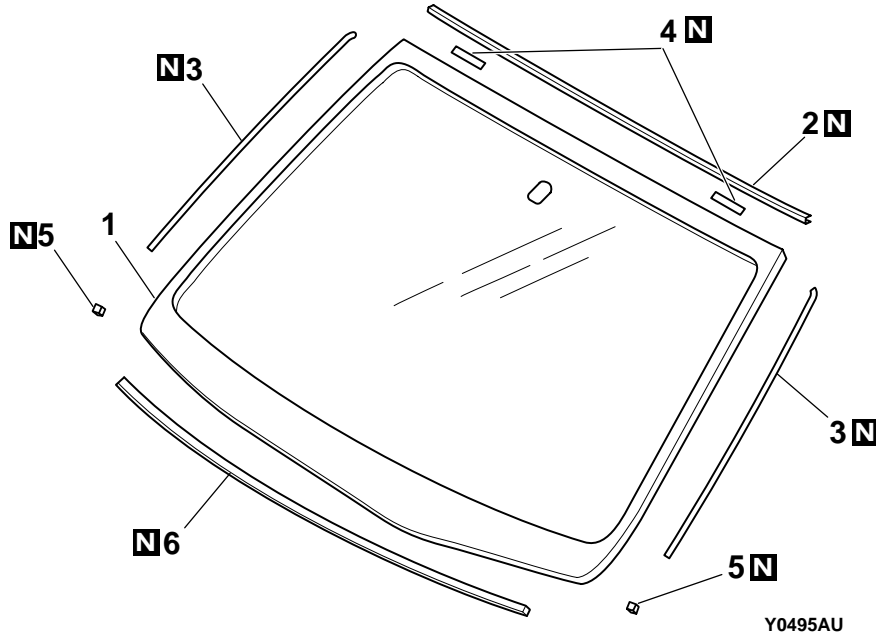

ADHESIVE: 3M™ AAD PART NO. 8609 SUPER FAST URETHANE PRIMER AND 3M™ AAD PART NO. 8608 SUPER FAST URETHANE PRIMER OR EQUIVALENT

AC006003AC

REMOVAL STEPS

- ROOF DRIP MOLDING (REFER TO GROUP 51, AIR DAM, MOLDING AND GARNISH P.51-8).

REMOVAL STEPS (Continued)

- <<A>> >>A<< 1. WINDSHIELD
- >>A<< 2. WINDSHIELD MOLDING
- >>A<< 3. WINDOW DAM

REMOVAL STEPS (Continued)

- >>A<< 4. GLASS STOPPER
- >>A<< 5. SPACER
- >>A<< 6. WINDSHIELD SPACER

Required Special Tool:

- MB990480: Glass Holder

REMOVAL SERVICE POINT

<<A>> WINDSHIELD REMOVAL

1. To protect the body (paint surface), apply cloth tape to all body areas around the installed
2. Make mating marks on the windshield and body.
3. Using piano wire.
 - (1) Using a sharp-point drill, make a hole in the windshield adhesive.
 - (2) Pass the piano wire from the inside of the vehicle through the hole.
 - (3) Using a sharp-point drill, make a hole in the windshield adhesive.
 - (4) Pass the piano wire from the inside of the vehicle through the hole.

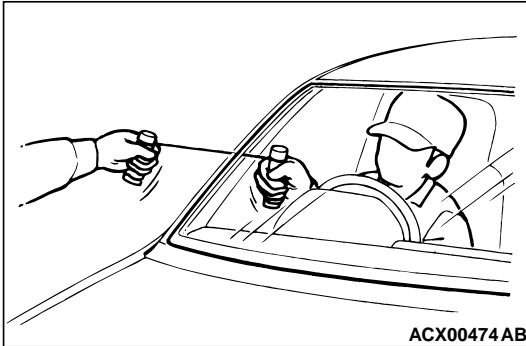

⚠ CAUTION

Do not let the piano wire touch the edge of the windshield.

- (5) Pull the piano wire alternately from the inside and outside along the windshield to cut the adhesive.

⚠ CAUTION

Putting glass adhesive knife too deeply into windshield adhesive may damage windshield.

4. Using glass adhesive knife

Keep glass adhesive knife at right angles with the windshield edge, and put the blade at windshield edge and surface. Then cut away adhesive along the windshield edge.

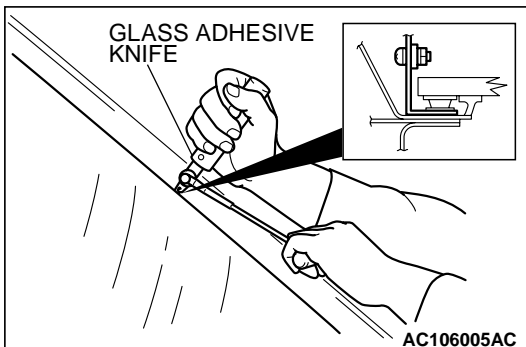
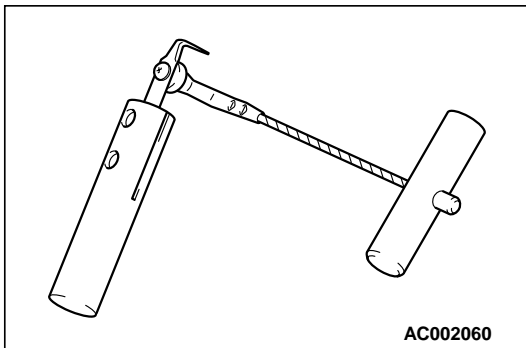

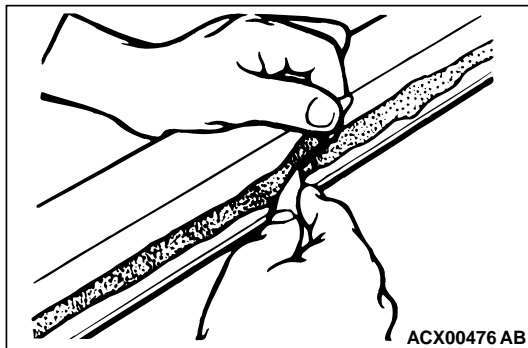
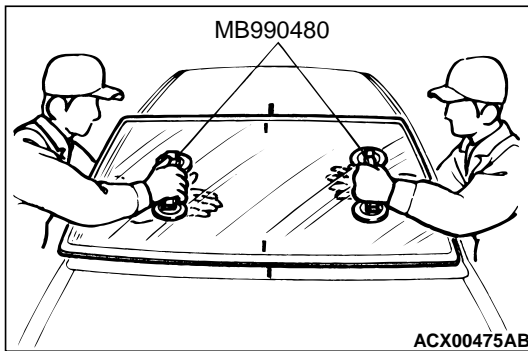

5. Use special tool MB990480 to remove the windshield.

⚠ CAUTION

- Be careful not to remove more adhesive than is necessary.
 - Be careful also not to damage the paintwork on the body surface with the knife. If the paintwork is damaged, repair the damaged area with repair paint or anti-rust agent.
6. Use a knife to cut away the remaining adhesive so that the thickness is within 2 mm (0.08 inch) around the entire circumference of the body flange.
 7. Finish the flange surfaces so that they are smooth.

⚠ CAUTION

Allow the cleaned area to dry for at least three minutes. Do not touch any surface that has been cleaned.

8. When reusing the windshield, remove the adhesive still adhering to the windshield, and clean with 3M™ AAD Part number 8906 or equivalent.
9. Clean the body side in the same way.

INSTALLATION SERVICE POINTS

>>A<< WINDSHIELD SPACER/SPACER/GLASS STOPPER/ WINDOW DAM/WINDSHIELD MOLDING/WINDSHIELD INSTALLATION

⚠ CAUTION

Leave the degreased parts for 3 or more minutes to dry well, before starting on the next step. Do not touch the degreased parts.

1. Use 3M™ AAD Part number 8906 or equivalent to degrease the inside and outside of the windshield and the body flanges.

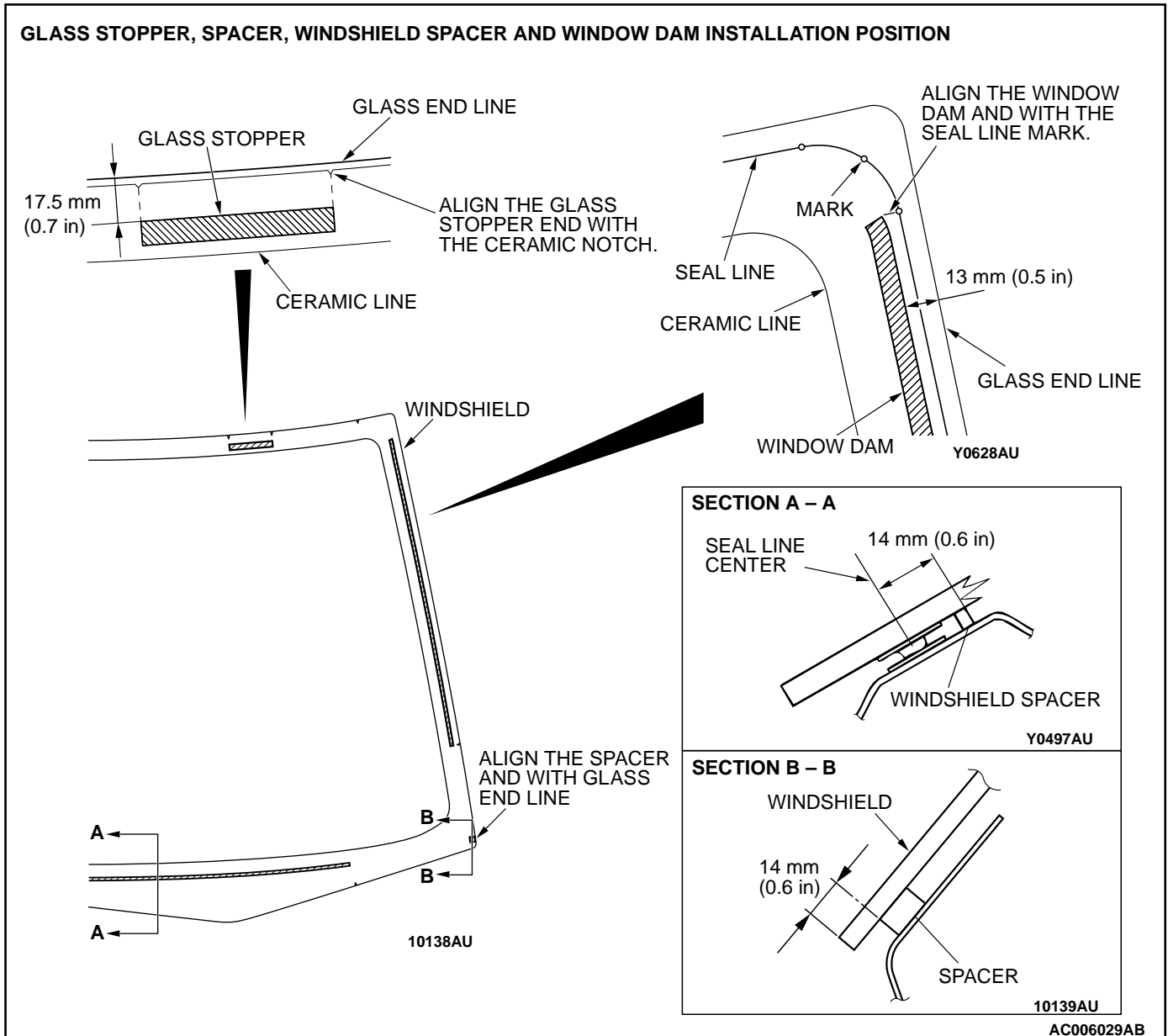

2. The inner side of the windshield is curved, therefore, make a point to assemble the glass stopper and windshield spacer without any lifting and assemble in the position shown in the Figure of the instructions.
3. Install the windshield molding.

>>B<< WINDSHIELD INSTALLATION

1. When replacing the windshield, temporarily set the windshield against the body, and place a mating mark on the windshield and body.

⚠ CAUTION

- The primer strengthens the adhesive, so be sure to apply it evenly around the entire circumference. However, a too thick application will weaken the adhesive.
 - Do not touch the coated surface.
2. Soak a sponge in the primer, and apply evenly to the windshield and the body in the specified places.

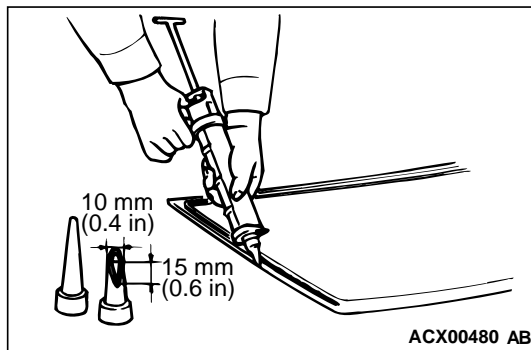

3. Allow the windshield to dry for at least three minutes after applying primer.
4. Fill a sealant gun with adhesive. Then apply the adhesive evenly around the windshield within 30 minutes after applying the primer.

NOTE: Cut the tip of the sealant gun nozzle into a V shape to simplify adhesive application.

5. Align the mating marks on the windshield and the body, and lightly press the windshield evenly so that it adheres completely.
6. Use a spatula or similar tool to remove any excessive adhesive. Clean the surface with 3M™ AAD Part number 8906 or equivalent. Avoid moving the vehicle until the adhesive sets.
7. Bond the windshield to the body, and install the roof drip molding quickly before the adhesive cures (Refer to GROUP51, Air dam, molding and garnish P.51-8).

⚠ CAUTION

- **Do not move the vehicle unless absolutely necessary.**
 - **When testing for water leakage, do not pinch the end of the hose to spray the water.**
8. Wait 30 minutes or more, and then test for water leakage.

REAR WINDOW GLASS

REMOVAL AND INSTALLATION

M1422001600100

Pre-removal and Post-installation Operation

- Rear Wiper Motor Assembly Removal and Installation (Refer to GROUP 51, Rear Wiper and Washer P.51-25).
- High Mount Stoplight Assembly Removal and Installation <Rear Shelf Mounted Type> (Refer to GROUP 54A, High Mount Stoplight P.54A-96).
- Rear Pillar Trim and Rear Shelf Trim Removal and Installation (Refer to GROUP 52A, Trims P.52A-11).
- Headlining Removal and Installation (Refer to GROUP 52A, Headlining P.52A-18).

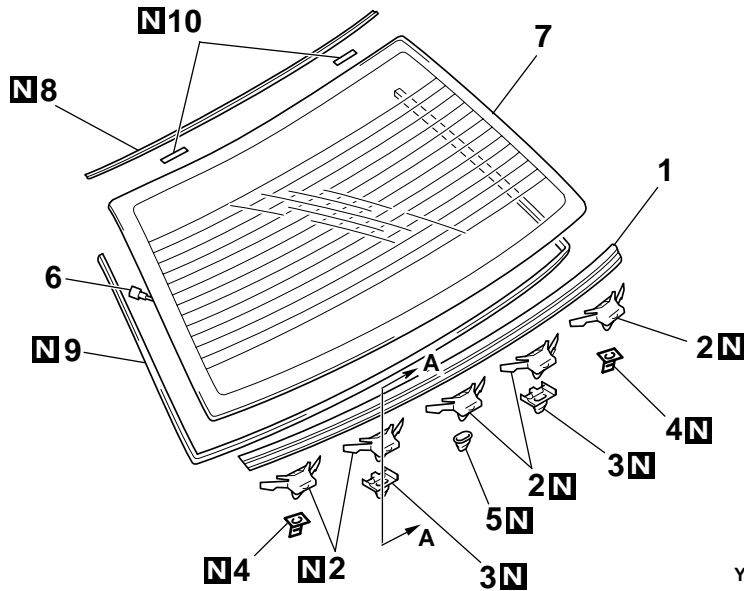

Y0500AU

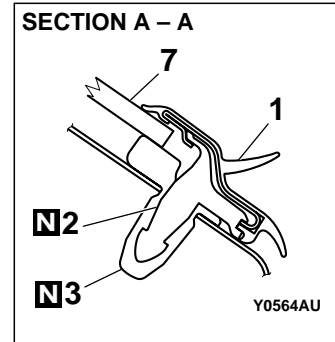

Y0564AU

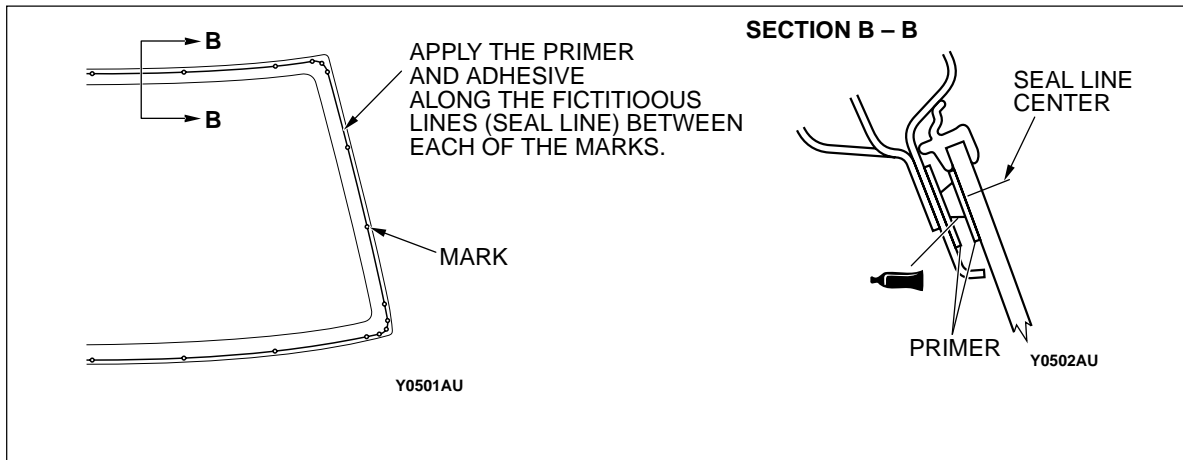

Y0501AU

Y0502AU

ADHESIVE: 3M™ AAD PART NO. 8609 SUPER FAST URETHANE PRIMER AND 3M™ AAD PART NO. 8608 SUPER FAST URETHANE PRIMER OR EQUIVALENT

AC006056 AC

REMOVAL STEPS

- ROOF DRIP MOLDING (REFER TO GROUP 51, AIR DAM, MOLDING AND GARNISH P.51-8).
- <<A>> >>B<<
1. REAR WINDOW LOWER MOLDING
 2. CLIP
 3. GROMMET A
 4. GROMMET B

REMOVAL STEPS (Continued)

5. GROMMET C
6. CONNECTING THE HARNESS CONNECTOR
- <> >>A<< 7. REAR WINDOW GLASS
- >>A<< 8. REAR WINDOW UPPER MOLDING
- >>A<< 9. WINDOW DAM
- >>A<< 10. GLASS STOPPER

Required Special Tools:

- MB990784: Ornament Remover

- MB990480: Glass Holder

REMOVAL SERVICE POINTS

<<A>> REAR WINDOW LOWER MOLDING REMOVAL

⚠ CAUTION

If the drip molding has become warped, it should not be reused.

Use special tool MB990784 to lever out the molding.

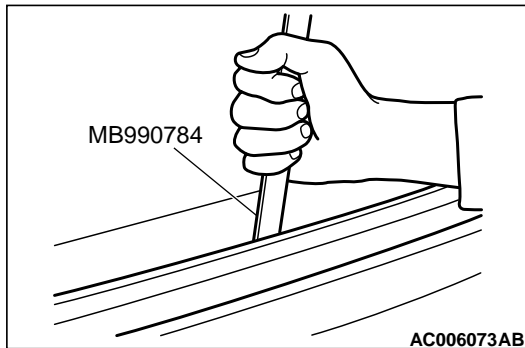

<> REAR WINDOW GLASS REMOVAL

Remove the rear window glass using the same procedure as for the windshield (Refer to P.42-15).

INSTALLATION SERVICE POINTS

>>A<< GLASS STOPPER/WINDOW DAM/REAR WINDOW UPPER MOLDING/REAR WINDOW GLASS INSTALLATION

1. When replacing the rear window glass, temporarily set the rear window glass against the body, and place a mating mark on the rear window glass and body.

⚠ CAUTION

Leave the degreased parts for 3 or more minutes to dry well, before starting on the next step. Do not touch the degreased parts.

2. Use 3M™ AAD Part number 8906 or equivalent to degrease the inside and outside of the rear window glass and the body flanges.

⚠ CAUTION

- The primer strengthens the adhesive, so be sure to apply it evenly around the entire circumference. However, a too thick application will weaken the adhesive.
 - Do not touch the coated surface.
3. Soak a sponge in the primer, and apply evenly to the rear window glass and the body in the specified places.
 4. Allow the rear window glass to dry for at least three minutes after applying primer.

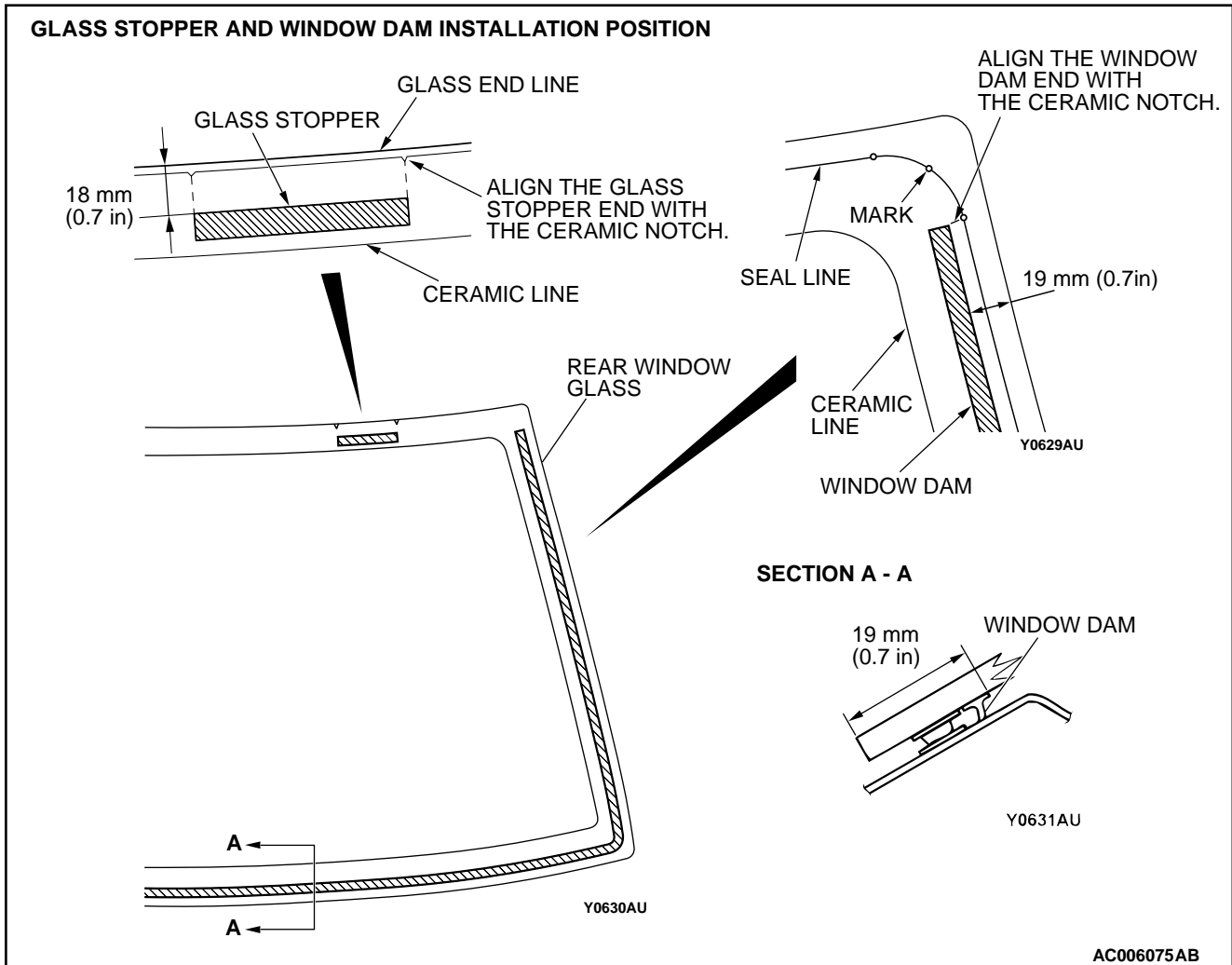

5. Install the glass stopper and window dam to the specified positions so that there are no adrift or bent surfaces inside the rear window glass.
6. Install the rear window upper molding.
7. Install the glass in the same manner as the windshield (Refer to [P.42-15](#)).

>>B<< REAR WINDOW LOWER MOLDING INSTALLATION

Install the clips to the rear window lower molding, and then fix the rear window molding to the vehicle body.

DOOR

GENERAL DESCRIPTION

OPERATION

CENTRAL DOOR LOCKING SYSTEM

The central door locking system operates the door lock actuator to lock or unlock the doors and liftgate using the operation of the door lock switch or key built into the driver's side inside door lock knob and front power window (main or sub) switch. The system has the following operations and features.

- Insert the key into the driver's key cylinder and turn once to the unlock side to unlock the driver's door. Turn the key once again to the unlock side to unlock all doors.
- All doors can be locked or unlocked using the front door <RH> key cylinder key operation.
- All doors and liftgate can be locked using the driver's inside door lock knob.
- All doors can be locked using the door lock switch built into the front power window (main or sub <RH>) switch.

CENTRAL DOOR LOCKING SYSTEM DIAGNOSIS

The central door locking system is controlled by the simplified wiring system (SWS). For troubleshooting, refer to GROUP 54B, Diagnosis [P.54B-22](#).

POWER WINDOW DIAGNOSIS

The power window is controlled by the simplified wiring system (SWS). For troubleshooting, refer to GROUP 54B, Diagnosis [P.54B-22](#).

DOOR DIAGNOSIS

INTRODUCTION TO GLASS AND DOOR DIAGNOSIS

Glass and door faults include water leaks and improper opening and closing. Causes for these faults can include faults in the glass, weatherstrip, drain hole, waterproof film or door installation.

GLASS AND DOOR DIAGNOSTIC TROUBLESHOOTING STRATEGY

Use these steps to plan your diagnostic strategy. If you follow them carefully, you will be sure that you have exhausted most of the possible ways to find a glass and door fault.

1. Gather information from the customer.

- A key reminder function that automatically unlocks all doors when door lock operation is performed and the front doors are opened while the key is inserted into the ignition switch is provided.

POWER WINDOWS

When the power window (main or sub) switch is operated, the door windows will open or close. This system has the following operations and features.

- There is a power window lock switch featured on the power window main switch to prevent the door window glass from opening/closing with the front passenger's and rear power window sub-switch.
- The power window of the door window glass can be opened/closed for 30 seconds with the timer function after the ignition switch is turned OFF. (The timer expires if the front door <LH or RH> is opened when the timer is in operation.)
- The power window main switch contains a one-touch down switch that will automatically open driver's side door window only.

M1423000100224

M1427000700198

M1429000700202

M1423007300230

M1423006700235

2. Verify that the condition described by the customer exists.
3. Find the malfunction by following the Symptom Chart.
4. Verify malfunction is eliminated.

SYMPTOM CHART

SYMPTOM	INSPECTION PROCEDURE	REFERENCE PAGE
Water leak through door window glass	1	P.42-24
Door window malfunction	2	P.42-24
Water leak through door edge	3	P.42-25
Water leak from door center	4	P.42-25
Door hard to open	5	P.42-25
Door does not open or close completely	6	P.42-26
Uneven gap between body	7	P.42-26
Wind noise around door	8	P.42-26

SYMPTOM PROCEDURES**INSPECTION PROCEDURE 1: Water Leak Through Door Window Glass****DIAGNOSIS**

STEP 1. Check the door window glass installation.

Q: Is the door window glass installed correctly?

YES : Go to Step 2.

NO : Assemble the door window glass again (Refer to P.42-34). Then go to Step 3.

STEP 2. Check the clearance at the top of the door window glass.

Q: Is the clearance at the top of the door window glass correct?

YES : Go to Step 3.

NO : Adjust the door window glass (Refer to P.42-30). Then go to Step 3.

STEP 3. Retest the system.

Q: Is any water leaking?

YES : Return to Step 1.

NO : The procedure is complete.

INSPECTION PROCEDURE 2: Door Window Glass Malfunction**DIAGNOSIS**

STEP 1. Check the door window glass installation condition.

Q: Is the door window glass installed correctly?

YES : Go to Step 2.

NO : Assemble the door window glass again (Refer to P.42-36). Then go to Step 4.

STEP 2. Check the door sash.

Q: Is the door sash in good condition?

YES : Go to Step 3.

NO : Repair or replace the door sash, then go to Step 4.

STEP 3. Inspect the window regulator assembly.

Q: Is the window regulator assembly in good condition?

YES : Go to Step 4.

NO : Repair or replace the window regulator assembly, then go to Step 4.

STEP 4. Retest the system.

- Q: Does the door window glass operate correctly?**
YES : The procedure is complete.
NO : Return to Step 1.

INSPECTION PROCEDURE 3: Water Leak Through Door Edge

DIAGNOSIS

STEP 1. Check the weatherstrip.

- Q: Is the weatherstrip in good condition?**
YES : Go to Step 2.
NO : Replace the weatherstrip, then go to Step 3.

STEP 2. Check the door fit (alignment).

- Q: Is the door fit (alignment) correct?**
YES : Go to Step 3.
NO : Adjust the door fit (Refer to [P.42-29](#)). Then go to Step 3.

STEP 3. Retest the system.

- Q: Is any water leaking?**
YES : Return to Step 1.
NO : The procedure is complete.

INSPECTION PROCEDURE 4: Water Leak from Door Center

DIAGNOSIS

STEP 1. Check the drain hole.

- Q: Is the drain hole clogged?**
YES : Clean the drain hole, then go to Step 3.
NO : Go to Step 2.

STEP 2. Check the weatherstrip.

- Q: Is the weatherstrip in good condition?**
YES : Go to Step 3.
NO : Repair or replace the weatherstrip, then go to Step 3.

STEP 3. Retest the system.

- Q: Is any water leaking?**
YES : Return to Step 1.
NO : The procedure is complete.

INSPECTION PROCEDURE 5: Door Hard to Open

DIAGNOSIS

STEP 1. Adjust the latch and striker engagement.
Refer to [P.42-29](#).

- Q: Is the latch and striker engagement adjusted?**
YES : Go to Step 2.
NO : Adjust the latch and striker (Refer to [P.42-29](#)). Then go to Step 4.

STEP 2. Check for lock rod damage.

- Q: Is the lock rod damaged?**
YES : Repair or replace the lock rod, then go to Step 4.
NO : Go to Step 3.

STEP 3. Check the door handle flexibility (amount of movement of handle required to open door).

Q: Is the door handle flexibility good?

YES : Go to Step 4.

NO : Adjust the door handle (Refer to [P.42-33](#) and [P.42-33](#)). Then go to Step 4.

STEP 4. Retest the system.

Q: Does the door open easily?

YES : The procedure is complete.

NO : Return to Step 1.

INSPECTION PROCEDURE 6: Door does not Open or Close Completely

DIAGNOSIS

STEP 1. Check the door hinge position.

Q: Is the door hinge correct?

YES : Go to Step 2.

NO : Adjust the door hinge (Refer to [P.42-29](#)). Then go to Step 4.

STEP 2. Check the door.

Q: Is the door in good condition?

YES : Go to Step 3.

NO : Repair or replace door, then go to Step 4.

STEP 3. Check the grease.

Q: Is the door check or door hinge grease sufficient?

YES : Go to Step 4.

NO : Apply the grease, then go to Step 4.

STEP 4. Retest the system.

Q: Does the door open and close correctly?

YES : The procedure is complete.

NO : Return to Step 1.

INSPECTION PROCEDURE 7: Uneven Gap Between Body

DIAGNOSIS

Adjust the door fit (Refer to [P.42-29](#)). Then check that the gap has been improved.

INSPECTION PROCEDURE 8: Wind Noise Around Door

DIAGNOSIS

STEP 1. Check the weatherstrip for holding condition.

Q: Is the weatherstrip holding firmly?

YES : Go to Step 2.

NO : Adjust fit of door (Refer to [P.42-31](#)). Then go to Step 5.

STEP 2. Check the weatherstrip for installation condition.

Q: Is the weatherstrip for installed properly?

YES : Go to Step 3.

NO : Repair or replace the weatherstrip. Then go to Step 5.

STEP 3. Check the clearance.

Q: Are the door glass and the door weatherstrip holder assembled correctly?

YES : Go to Step 4.

NO : Adjust the door glass and the door weatherstrip (Refer to [P.42-31](#)). Then go to Step 5.

STEP 4. Check the door.

Q: Is the door deformed?

YES : Repair or replace the door. then go to Step 5.

NO : Go to Step 5.

STEP 5. Retest the system.

Q: Has the wind noise been improved?

YES : Return to Step 1.

NO : This diagnosis complete.

HOW TO LOCATE WIND NOISE

M1421004200205

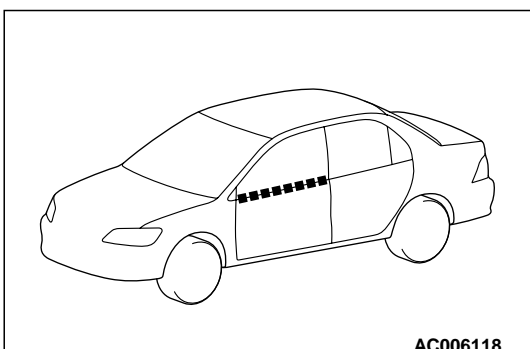
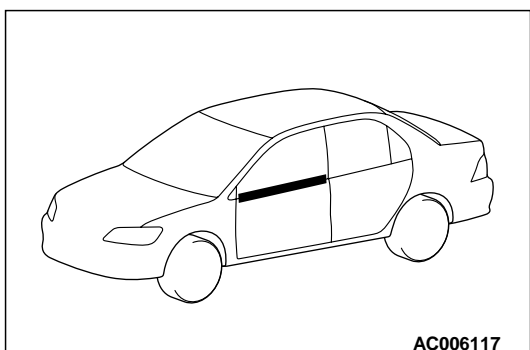
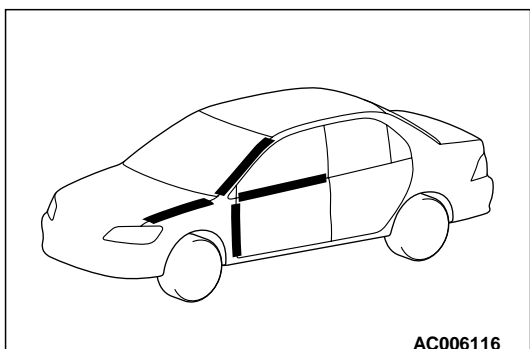
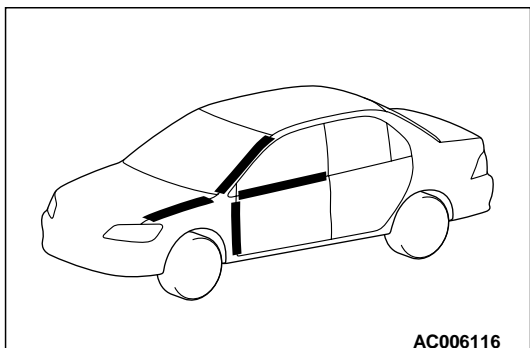

1. Attach cloth tape to every place, such as panel seams, projections, molding seams, glass and body seams, etc. which might conceivably be the source of wind noise.
2. Then make a road test to check that the places not covered by tape are not sources of wind noise.

3. Remove the strips of tape one by one, making a road test after each is removed, until a wind noise source is discovered.

4. When such a place is found, cover it again and repeat the procedure to check if there are any other noise source.
5. If no others are found, the last remaining tape is the only source.

6. Cut the remaining piece of tape into smaller pieces, attach it again as it was before, and then remove the pieces one by one to narrow down the source.

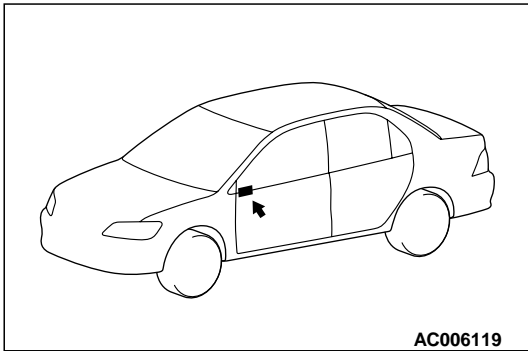

7. Check that wind noise occurs when the last remaining tape is removed, and that noise does not occur when it is re-attached.
8. When the source(s) of the wind noise is finally located, attach butyl tape, body sealer or similar material to obstruct this source as much as possible.

SPECIAL TOOLS

M1423000600296

TOOL	TOOL NUMBER AND NAME	SUPERSESSION	APPLICATION
<p>MB990900</p>	MB990900 or MB991164 Door adjusting wrench	MB990900-01	Adjustment of door fit
<p>MB990925AD</p>	MB990925 Bearing and oil seal installer set A: MB990939 Brass bar	MB990925-01 or General service tool	Adjustment of door striker
<p>MB990211</p>	MB990211 Slider hammer	MB990211-01	
<p>MB990241AC</p>	MB990241 Axle shaft puller A: MB990243 Body puller	MB990241-01 or General service tool	
<p>MB990784</p>	MB990784 Ornament remover	General service tool	Removal of door trim
<p>MB990480</p>	MB990480 Glass holder	General service tool	Removal of power window regulator assembly

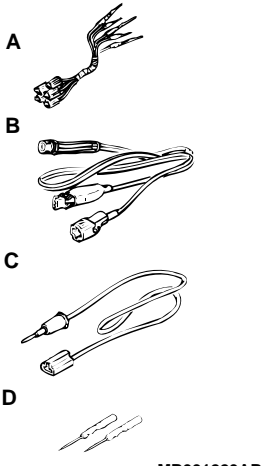
TOOL	TOOL NUMBER AND NAME	SUPERSESION	APPLICATION
 <p>MB991223AB</p>	<p>MB991223 Harness set A: MB991219 Test harness B: MB991220 LED harness C: MB991221 LED harness adapter D: MB991222 Probe</p>	<p>MB991223</p>	<p>Measurement of terminal voltage A: Connector pin contact pressure inspection B: Power circuit inspection C: Power circuit inspection D: Commercial tester connection</p>

ON-VEHICLE SERVICE

DOOR FIT ADJUSTMENT

M1423001100153

Required Special Tools:

- MB990211: Slide Hammer
- MB990243: Body Puller
- MB990900 or MB991164: Door adjusting Wrench
- MB990939: Brass Bar

⚠ CAUTION

- **Attach protection tape to the fender and door edges where the hinge is installed.**
- **Do not rotate special tool MB991164 with a torque of over 98 N·m (72 ft-lb)**

1. Use special tool MB990900 or MB991164 to loosen the hinge mounting bolts on the body side, and then adjust the clearance around the door so that it is uniform on all sides.
2. If a door is not flush with its surrounding panels, loosen the door-side door hinge mounting bolts and obtain the flushness by moving the door.

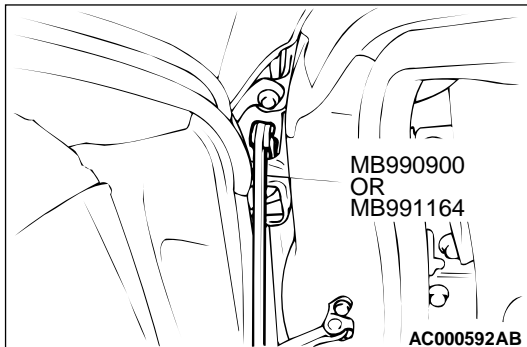

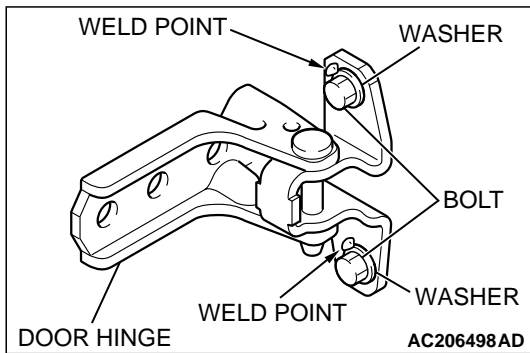

NOTE: If the door hinge mounting bolt washers are welded, grind off the welding according to the procedure below beforehand.

1. Remove the door hinge (Refer [P.42-34](#)).
2. Use a chisel or grinder to release the door hinge mounting bolt washer, which is welded to the door hinge.
3. On completion, paint the affected area with a suitable touch-in brush to prevent corrosion.
4. Install the door hinge (Refer [P.42-34](#)).

3. When the door is stiff to lock and unlock:

- (1) Adjustment by using the striker (toward the inside of the vehicle and vertical direction).

Install an appropriate bolt instead of the striker mounting bolt, and use special tool MB990939 and a hammer to tap the bolt to the desired direction.

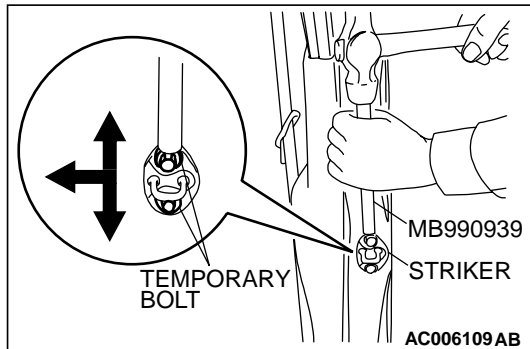

- (2) Adjustment by using the striker (toward the outside of the vehicle).

Use special tools MB990211 and MB990243 to pull the striker toward the outside of the vehicle.

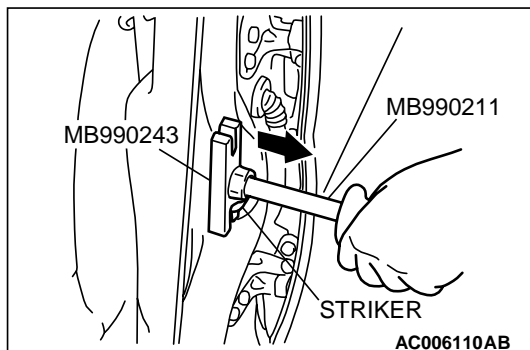

- (3) Adjustment by using shims (forward and rearward).

Increase or decrease the number of shims so that the striker engages with the door latch properly.

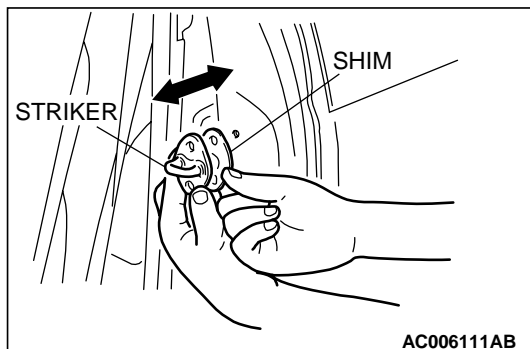

DOOR WINDOW GLASS ADJUSTMENT

M1423001000264

Check that the door glass moves while contacting the door glass channel when it is raised and lowered fully. If not, adjust the door window according to the following procedures.

1. Remove the door trim (Refer to GROUP 52A, Door trim Refer to [P.52A-13](#)).
2. Remove the waterproof film (Refer to [P.42-45](#)).

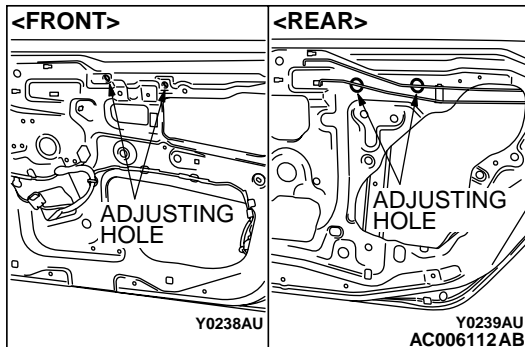

3. Loosen the door glass mounting screw via the adjusting hole with the door window glass fully closed, then lower the window glass a little.
4. Fully close the door window glass again and tighten the door glass mounting screw firmly via the adjusting hole.

GLASS SLIDING MECHANISM CHECK AND ADJUSTMENT

M1429000900079

If the window glass automatically starts moving downwards at the wrong time while it is being raised, carry out the following adjustment or replacement procedures.

1. Remove the door trim (Refer to GROUP 52A, Door trim Refer to [P.52A-13](#)).
2. Remove the waterproof film (Refer to [P.42-45](#)).
NOTE: Insert a cushion or similar object to prevent damage to the glass if it should happen to fall down.
3. Remove the window regulator assembly from the door window glass, and then raise and lower the door window glass by hand to check the operation force.
4. If the door window glass does not move up and down smoothly, check or repair the following points.
 - Check the installation condition of the runchannel.
 - Repair any twisting in the door sash.
 - Check the installation condition of the lower sash or the center sash.

NOTE: The lower sash cannot normally be adjusted, but it may be possible to adjust the sash span slightly within the range allowed by manufacturing tolerances by pushing the lower sash outwards while re-installing it.

5. If repair or adjustment is not possible, replace the door assembly.

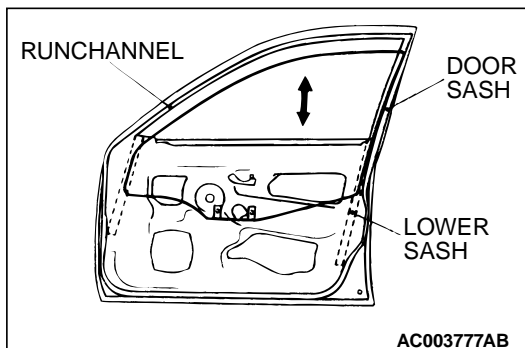

POWER WINDOW TIMER FUNCTION CHECK

M1429004300110

After the doors are closed and the ignition switch is turned to the "LOCK" (OFF) position, the power windows should work within 30 seconds. The timer expires at the point the front door is opened during that 30 second time. If not, carry out the troubleshooting (Refer to GROUP 54B, Diagnosis [P.54B-6](#)).

POWER WINDOW OPERATING CURRENT CHECK

M1429001100140

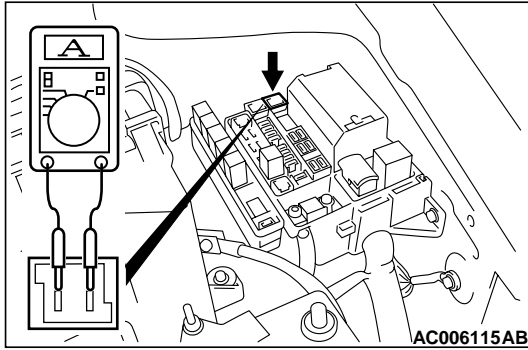

1. Remove the power window fuse and connect an ammeter as shown in the illustration.
2. When the power window switch is pressed to the “UP” position, a large amount of current flows at the time the window starts to close and when it is fully closed, so measure the operation current in the interval between these two points.

Standard value (A): $5 \pm 1A$ [Power supply voltage $14.5 \pm 0.5V$, $25^{\circ}C$ ($77^{\circ}F$)]

3. If the operation current is outside the standard value, refer to GROUP 54B Diagnosis P.54B-22.

POWER WINDOW RELAY CHECK

M1429001800161

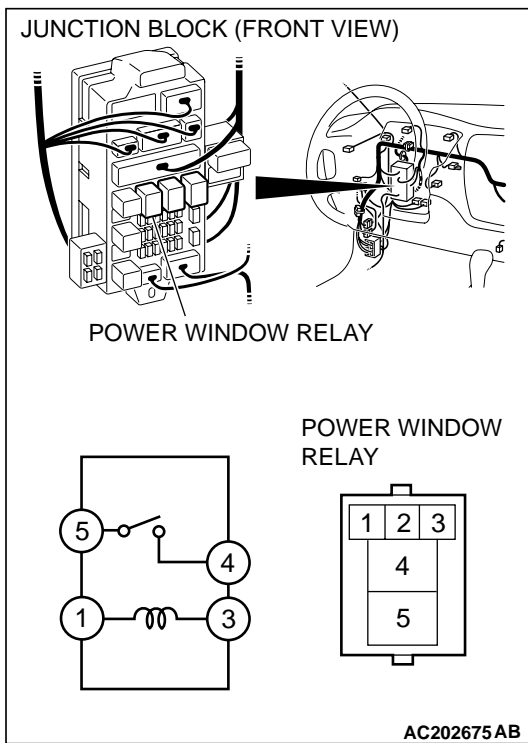

BATTERY VOLTAGE	TESTER CONNECTION	SPECIFIED CONDITION
Not applied	4 – 5	Open circuit
<ul style="list-style-type: none"> • Connect terminal No. 1 and the positive battery terminal. • Connect terminal No. 3 and the negative battery terminal. 		Less than 2 ohms

CIRCUIT BREAKER (INCORPORATED IN THE POWER WINDOW MOTOR) INSPECTION

M1429001000239

1. Pull the power window switch to the UP position to fully close the door window glass, and keep pulling the switch for 10 additional seconds.
2. Release the power window switch from the UP position and immediately press it to the DOWN position. The condition of the circuit breaker is good if the door window glass starts to move downwards within 60 seconds.

POWER WINDOW CHECK

M1429004400151

1. Operate the power window switch of each seat to check and see that the power windows operate properly. If they don't then execute troubleshooting remedies (Refer to GROUP 54B, Diagnosis P.54B-6).
2. Turn ON the power window lock switch of the power window main switch. Then operate the passenger's seat and back seat's power window sub switch to ensure that they do not operate. If they do, replace the power window main switch (Refer to P.42-36).

CENTRAL DOOR LOCKING SYSTEM INSPECTION

M1427001100092

Check the following. Execute troubleshooting procedures if operations malfunction (Refer to GROUP 54B, Diagnosis P.54B-6).

- Insert the key into the driver's key cylinder and turn once to the unlock side to unlock the driver's door. Turn the key once again to the unlock side to unlock all doors.
- All doors can be locked or unlocked using the front door <RH> key cylinder key operation.
- All door can be locked using the driver's inside door lock knob.
- All doors can be locked using the door lock switch built into the front power window (main or sub <RH>) switch.

DOOR OUTSIDE HANDLE PLAY CHECK

M1423001600233

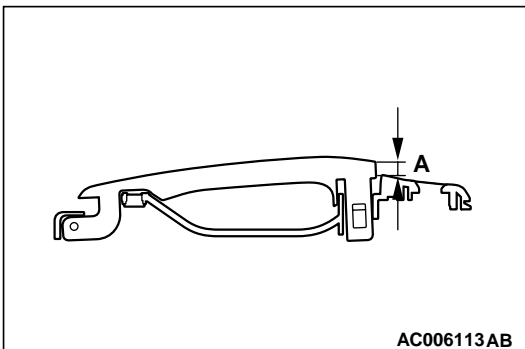

1. Check that the door outside handle play is within the standard value range.

Standard value (A):

Front door: 2.3 ± 2.1 mm (0.09 ± 0.08 inch)

Rear door: 1.3 ± 1.7 mm (0.05 ± 0.07 inch)

2. If the door outside handle play is not within the standard value range, check the door outside handle or the door latch assembly. Replace, if necessary.

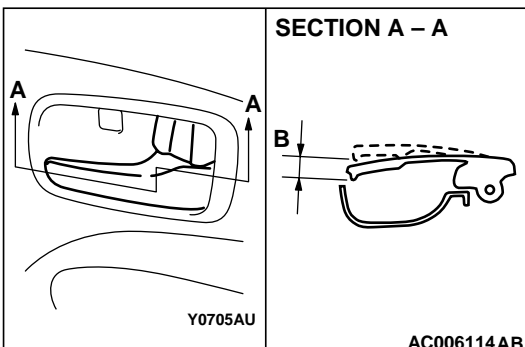

DOOR INSIDE HANDLE PLAY ADJUSTMENT

M1423001500258

1. Check that the door inside handle play is within the standard value range.

Standard value (B):

Front door: 10.4 ± 9.6 mm (0.41 ± 0.38 inch)

Rear door: 10 ± 9.6 mm (0.39 ± 0.38 inch)

2. If the door inside handle play is outside the standard value range.
3. Remove the door trim assembly (Refer to P.52A-13).
4. Remove the waterproof film (Refer to P.42-45.)

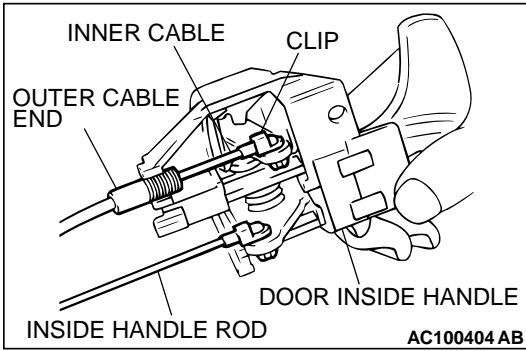

- Adjust the door inside handle play with the outer cable end connecting the door inside handle and inside lock cable.

DOOR ASSEMBLY REMOVAL AND INSTALLATION

M1423002200249

Post-installation Operation

- Door Fit Adjustment (Refer to P.42-29).

<FRONT DOOR>

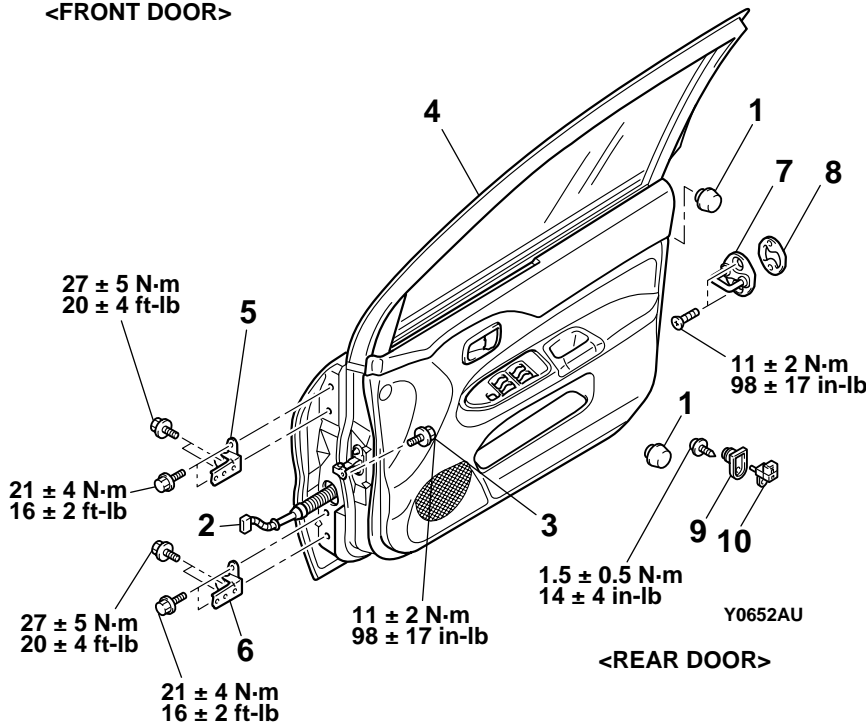

<REAR DOOR>

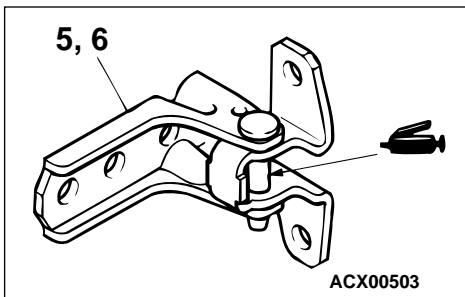
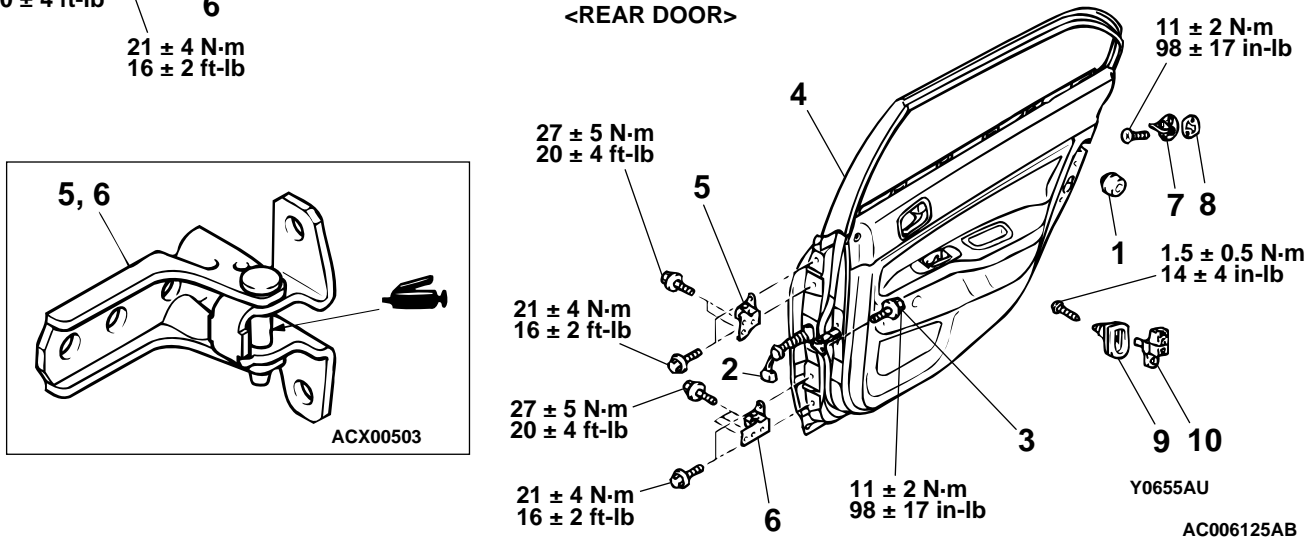

REMOVAL

1. DAMPER MAIL
- DOOR ASSEMBLY REMOVAL STEPS**
2. HARNESS CONNECTOR
3. DOOR CHECK CONNECTING BOLT
4. DOOR ASSEMBLY
5. DOOR UPPER HINGE
6. DOOR LOWER HINGE

- >>A<<
7. STRIKER
 8. STRIKER SHIM
 - DOOR SWITCH REMOVAL STEPS**
 9. DOOR SWITCH CAP
 10. DOOR SWITCH

INSTALLATION SERVICE POINT

>>A<< **STRIKER INSTALLATION**

Align the center of the striker and latch within ± 1.5 mm (0.06 inch), and install.

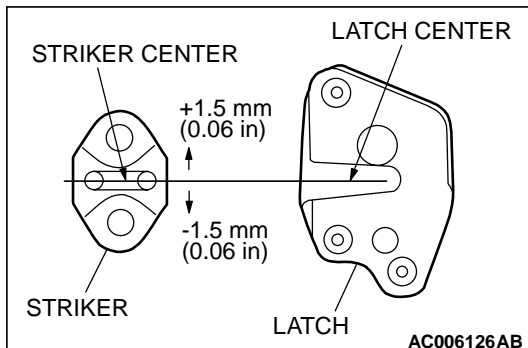

INSPECTION

M1423006000292

DOOR SWITCH CHECK

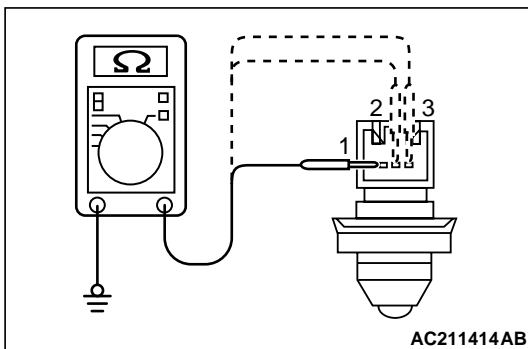

SWITCH POSITION	TESTER CONNECTION	SPECIFIED CONDITION
Released (ON)	1 – switch body, 2 – switch body, 3 – switch body	Less than 2 ohms
Depressed (OFF)	1 – switch body, 2 – switch body, 3 – switch body	Open circuit

**DOOR GLASS AND REGULATOR
REMOVAL AND INSTALLATION**

M1429001300263

Post-installation Operation

- Door Window Glass Adjustment (Refer to P.42-30).

<FRONT DOOR>

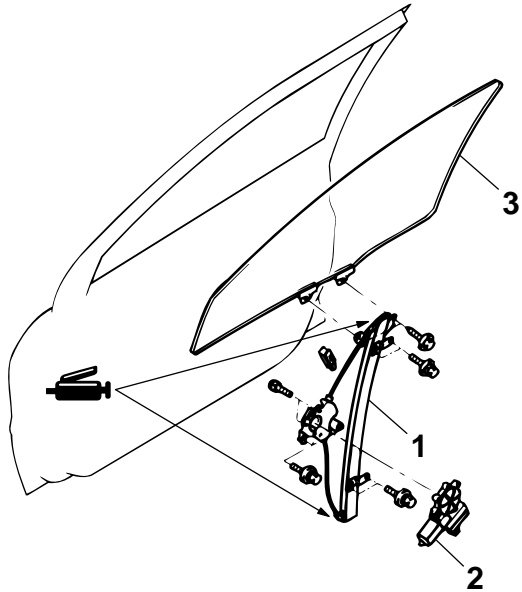

<REAR DOOR>

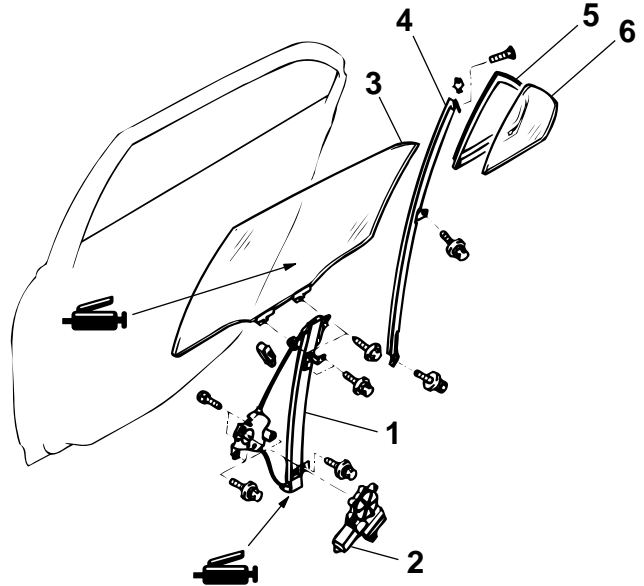

AC212124 AB

<FRONT DOOR>

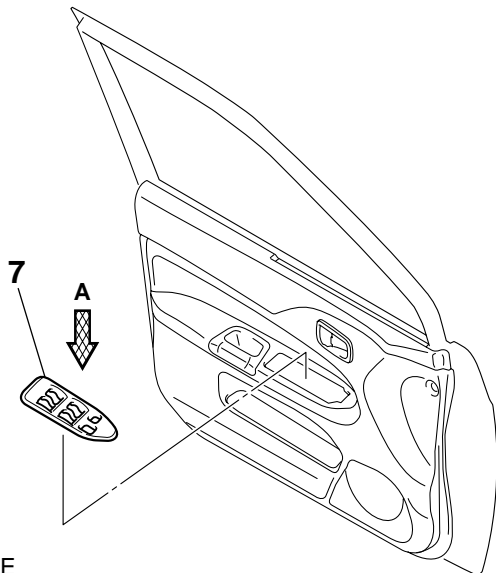

NOTE
 ←: CLIP POSITIONS
 ⇐: CLAW POSITIONS

VIEW A

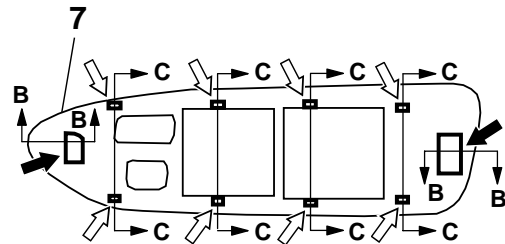

SECTION B - B

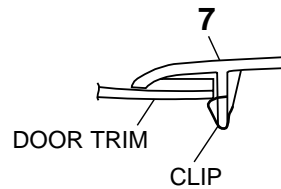

SECTION C - C

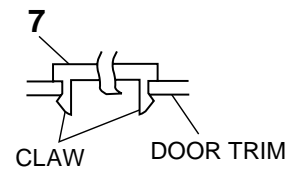

AC212119 AB

<REAR DOOR>

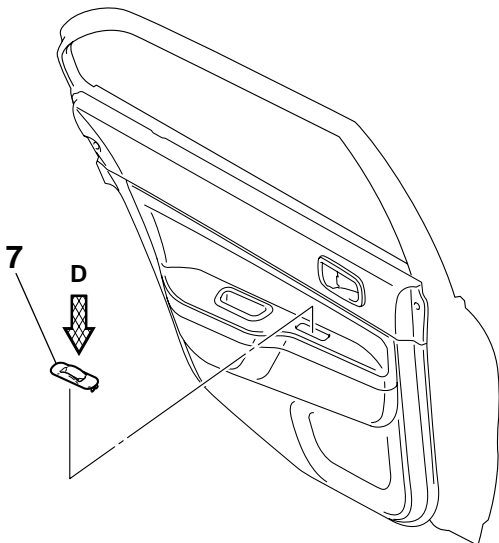

VIEW D

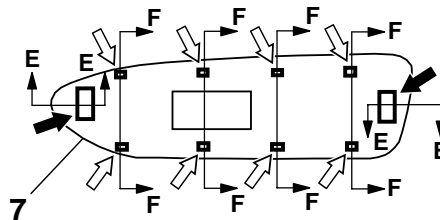

SECTION E - E

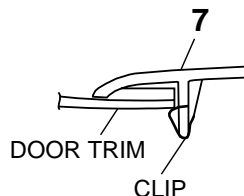

SECTION F - F

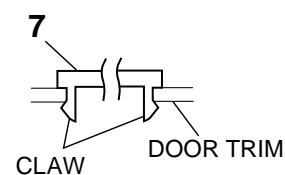

NOTE

- ← : CLIP POSITIONS
- ⇨ : CLAW POSITIONS

DOOR WINDOW REGULATOR ASSEMBLY REMOVAL STEPS

- <<A>> >>B<< 1. WINDOW REGULATOR ASSEMBLY
- <<A>> >>B<< 2. POWER WINDOW REGULATOR MOTOR ASSEMBLY

DOOR WINDOW GLASS REMOVAL STEPS

- WINDOW GLASS RUNCHANNEL (REFER TO P.42-45.)
- 3. DOOR WINDOW GLASS

STATIONARY WINDOW GLASS REMOVAL STEPS

- WINDOW GLASS RUNCHANNEL (REFER TO P.42-45.)
- DOOR BELTLINE INNER WEATHERSTRIP (REFER TO P.42-45.)

STATIONARY WINDOW GLASS REMOVAL STEPS (Continued)

- <> >>A<< 3. DOOR WINDOW GLASS
- <> >>A<< 4. CENTER SASH UPPER
- <> >>A<< 5. STATIONARY WINDOW GLASS
- <> >>A<< 6. STATIONARY WINDOW WEATHERSTRIP

POWER WINDOW SWITCH REMOVAL STEPS

- 7. POWER WINDOW SWITCH PANEL ASSEMBLY

Required Special Tool:

- MB990480: Window Glass Holder

AC212120

REMOVAL SERVICE POINTS**<<A>> WINDOW REGULATOR ASSEMBLY/POWER WINDOW REGULATOR MOTOR ASSEMBLY REMOVAL**

1. Remove the door window glass installation bolts.

⚠ CAUTION

If film or others are adhered to the door window glass, attach special tool MB990480 to the outside of the glass to prevent the film from peeling off.

2. Lift the door window glass, and attach special tool MB990480 to the glass as shown to prevent the glass from falling.
3. Remove the window regulator assembly and power window motor assembly

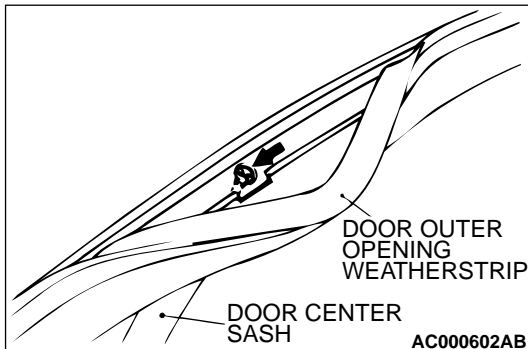
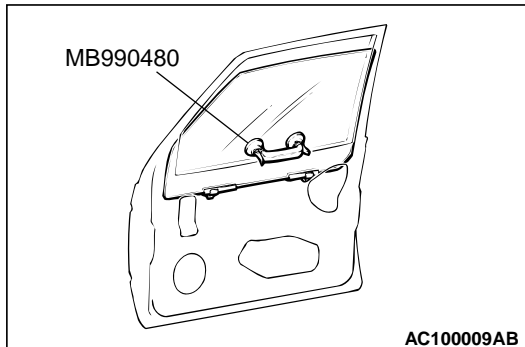
**<> CENTER SASH UPPER REMOVAL**

1. Remove the door outer opening weatherstrip from the center sash upper only.
2. Remove the center sash upper mounting screws, and then remove the center sash upper from the door panel.

INSTALLATION SERVICE POINTS**>>A<< CENTER SASH UPPER INSTALLATION**

Securely insert the center sash upper into the window rear sash (door).

>>B<< WINDOW REGULATOR ASSEMBLY/POWER
WINDOW REGULATOR MOTOR ASSEMBLY
INSTALLATION

When installing the window regulator assembly, tighten the bolts to the specified torque in the order shown.

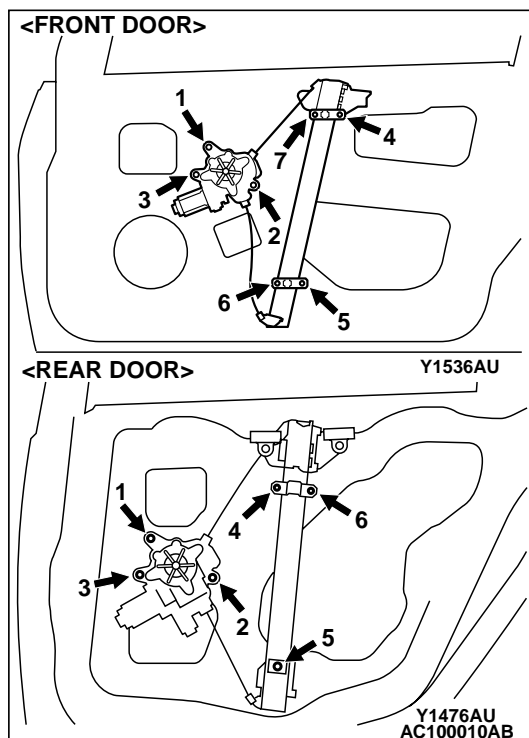

INSPECTION

M1429001400237

POWER WINDOW SWITCH CONTINUITY CHECK

Power window main switch's front <LH> switch check

Connect the terminal number 13 to the battery (+) post, and the terminal number 12 to the battery (-) post.

Main switch

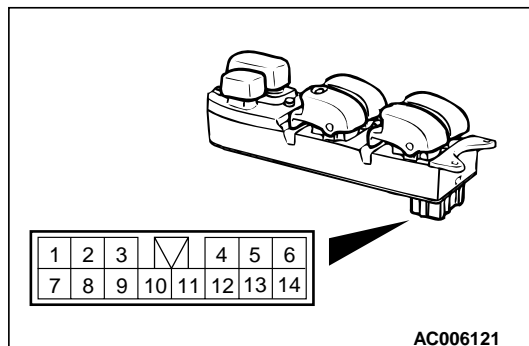

SWITCH POSITION		TESTER CONNECTION	SPECIFIED CONDITION
FRONT (LH)	UP	8 - 13, 9 - 12,	Less than 2 ohms
	OFF	8 - 12, 9 - 12, 8 - 9	
	DOWN	9 - 13, 8 - 12	
FRONT (RH)	UP	3 - 13, 11 - 12*	Less than 2 ohms
	OFF	3 - 11, 3 - 12*, 11 - 12*	
	DOWN	11 - 13, 3 - 12*	
REAR (LH)	UP	1 - 13, 2 - 12*	Less than 2 ohms
	OFF	1 - 2, 1 - 12*, 2 - 12*	
	DOWN	2 - 13, 1 - 12*	
REAR (RH)	UP	14 - 13, 6 - 12*	Less than 2 ohms
	OFF	6 - 14, 6 - 12*, 14 - 12*	
	DOWN	6 - 13, 14 - 12*	

NOTE: *: Set switch to UNLOCK position

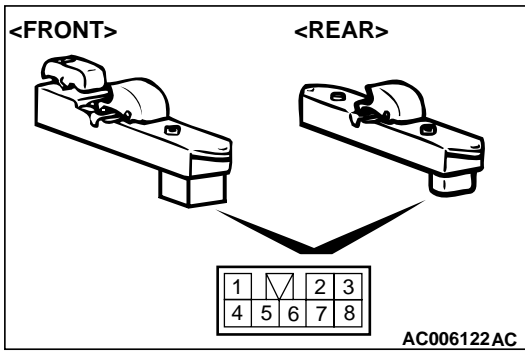

Sub switch

SWITCH POSITION		TESTER CONNECTION	SPECIFIED CONDITION
Sub switch	UP	5 – 7, 6 – 8	Less than 2 ohms
	OFF	4 – 7, 6 – 8	
	DOWN	4 – 7, 5 – 6	

POWER WINDOW REGULATOR MOTOR CONTINUITY CHECK

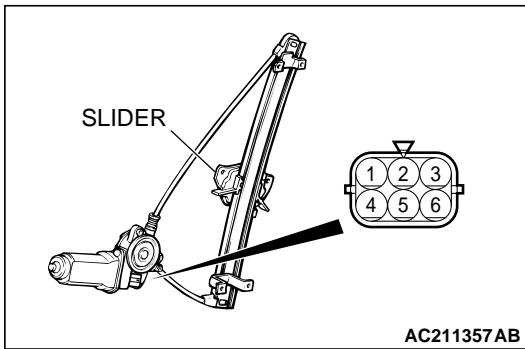

BATTERY CONNECTION	SLIDER POSITION
<ul style="list-style-type: none"> • Connect terminal No. 1 and the negative battery terminal. • Connect terminal No. 4 and the positive battery terminal. 	UP
<ul style="list-style-type: none"> • Connect terminal No. 4 and the negative battery terminal. • Connect terminal No. 1 and the positive battery terminal. 	DOWN

**DOOR HANDLE AND LATCH
REMOVAL AND INSTALLATION**

M1423004600287

Pre-removal Operation

- Door Trim Removal (Refer to P.52A-13).

Post-installation Operation

- Door Inside Handle Play Check (Refer to P.42-33).
- Door Outside Handle Play Check (Refer to P.42-33).
- Door Trim Installation (Refer to P.52A-13).

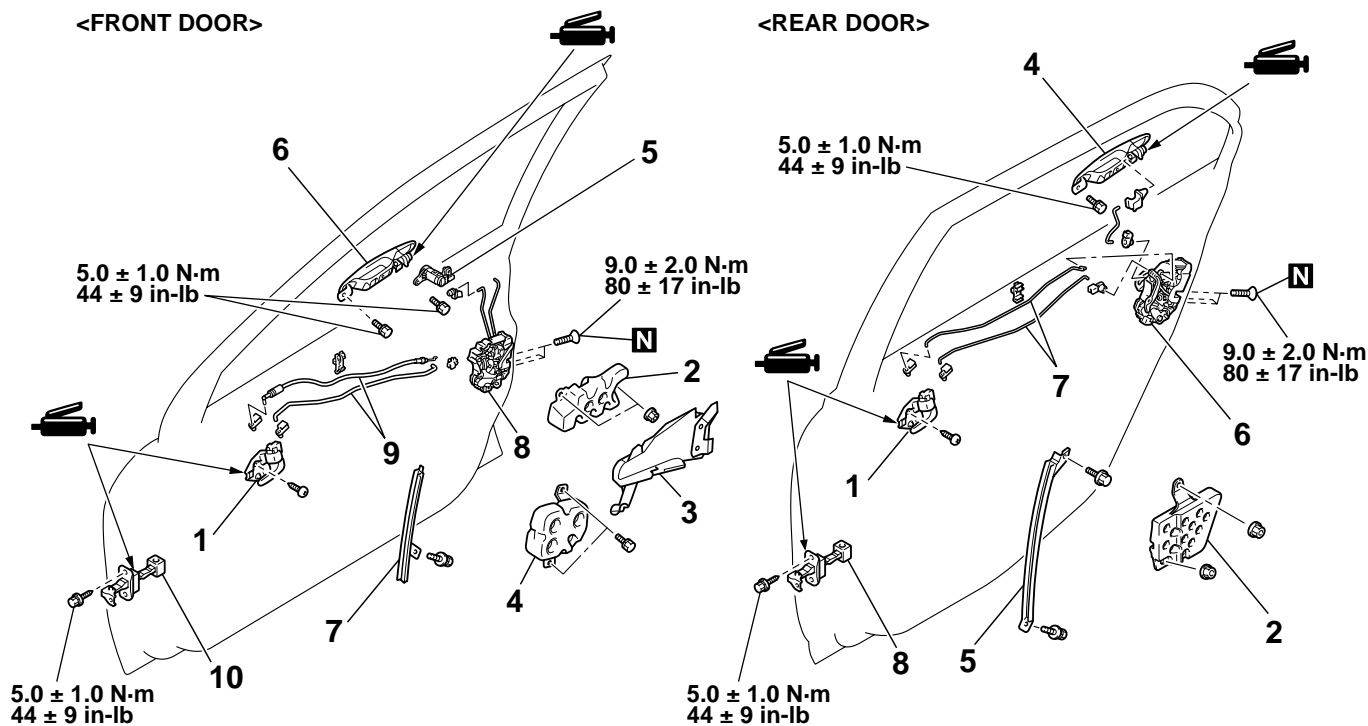

AC211922 AB

**DOOR HANDLE AND DOOR LATCH
ASSEMBLY REMOVAL STEPS**

- >>C<<
1. DOOR INSIDE HANDLE
 - WATERPROOF FILM (REFER TO P.42-45).
 2. DOOR ENERGY ABSORBER CORE
 3. DOOR ENERGY ABSORBER UPPER CORE
 4. DOOR ENERGY ABSORBER LOWER CORE
 - DOOR BELTLINE INNER WEATHERSTRIP (REFER TO P.42-45).

**DOOR HANDLE AND DOOR LATCH
ASSEMBLY REMOVAL STEPS**

- CENTER SASH UPPER (REAR DOOR) (REFER TO P.42-36).
5. DOOR LOCK KEY CYLINDER
 6. DOOR OUTSIDE HANDLE
- >>B<<
7. LOWER SASH
 8. DOOR LATCH ASSEMBLY
 9. LINK
- DOOR CHECK REMOVAL STEPS**
- WATERPROOF FILM (REFER TO P.42-45).
- >>A<<
10. DOOR CHECK

INSTALLATION SERVICE POINTS

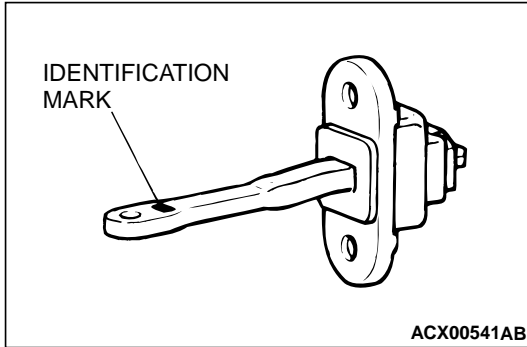

>>A<< DOOR CHECK INSTALLATION

Install the door check so that the identification mark faces upwards.

ITEM		IDENTIFICATION MARK
Front Door	Left door	39L
	Right door	39R
Rear Door	Left door	40L
	Right door	40R

>>B<< LOWER SASH INSTALLATION

Securely insert the rear lower sash into the window rear sash.

>>C<< DOOR INSIDE HANDLE INSTALLATION

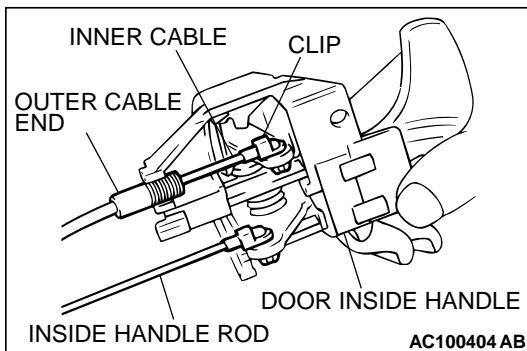

1. Install the inside lock cable to the door inside handle as follows:
 - (1) Install the inner cable end in the inside lock cable to the clip in the door inside handle.
 - (2) Turn the inside lock knob to the door lock position.
 - (3) Install the outer cable end to the door inside handle securely.
 - (4) Install the clip to the inner cable.
2. Install the inside handle rod to the door inside handle.
3. Install the door inside handle to the door.

INSPECTION

FRONT DOOR LOCK ACTUATOR CHECK

Actuator Operation Check

LEVER POSITION	BATTERY CONNECTION	LEVER OPERATION
At the "LOCK" position	<ul style="list-style-type: none"> Connect terminal No. 4 and the negative battery terminal. Connect terminal No. 6 and the positive battery terminal. 	The lever moves from the "LOCK" position to the "UNLOCK" position.
At the "UNLOCK" position	<ul style="list-style-type: none"> Connect terminal No. 6 and the negative battery terminal. Connect terminal No. 4 and the positive battery terminal. 	The lever moves from the "UNLOCK" position to the "LOCK" position.

Actuator Switch Check <Left side>

LEVER POSITION	TESTER CONNECTION	SPECIFIED CONDITION
At the "LOCK" position	1 - 2	Open circuit
At the "UNLOCK" position		Less than 2 ohms

REAR DOOR LOCK ACTUATOR CHECK

Actuator Operation Check

LEVER POSITION	BATTERY CONNECTION	LEVER OPERATION
At the "LOCK" position	<ul style="list-style-type: none"> Connect terminal No. 4 and the negative battery terminal. Connect terminal No. 6 and the positive battery terminal. 	The lever moves from the "LOCK" position to the "UNLOCK" position.
At the "UNLOCK" position	<ul style="list-style-type: none"> Connect terminal No. 6 and the negative battery terminal. Connect terminal No. 4 and the positive battery terminal. 	The lever moves from the "UNLOCK" position to the "LOCK" position.

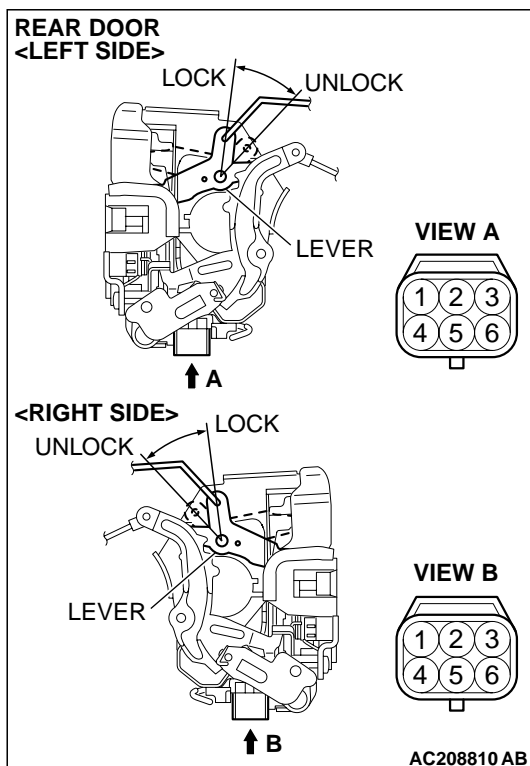
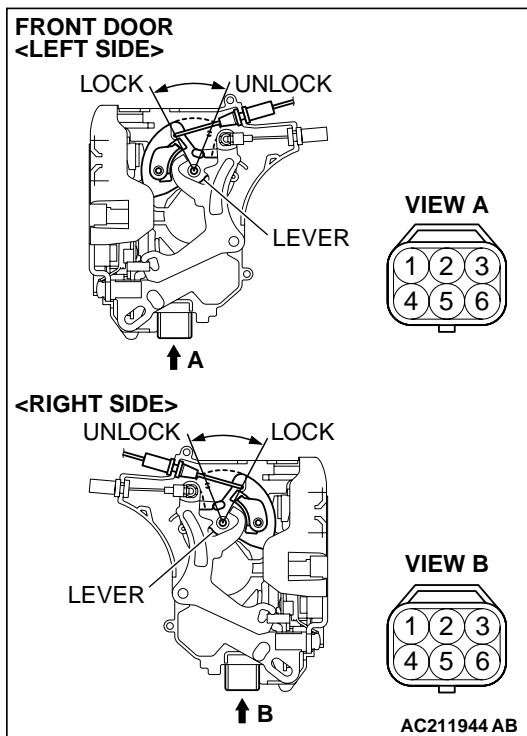

DOOR LOCK KEY CYLINDER SWITCH CHECK

<Driver's side>

SWITCH POSITION	TESTER CONNECTION	SPECIFIED CONDITION
LOCK	2 – 3	Less than 2 ohms
NEUTRAL (OFF)	1 – 2, 2 – 3	Open circuit
UNLOCK	1 – 2	Less than 2 ohms

<Passenger's side>

SWITCH POSITION	TESTER CONNECTION	SPECIFIED CONDITION
LOCK	1 – 2	Less than 2 ohms
NEUTRAL (OFF)	1 – 2, 2 – 3	Open circuit
UNLOCK	2 – 3	Less than 2 ohms

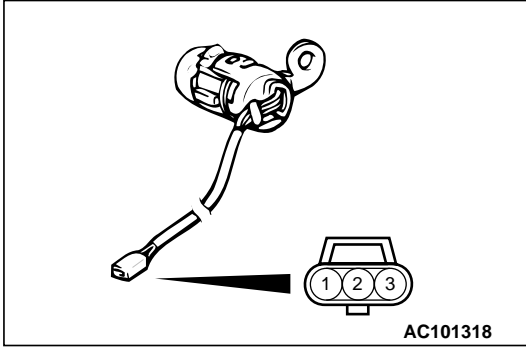

CENTRAL DOOR LOCK SWITCH CONTINUITY CHECK

Remove the power window switch. (Refer to P.42-36.)

<Driver's side>

SWITCH POSITION	TESTER CONNECTION	SPECIFIED CONDITION
LOCK	5 – 12	Less than 2 ohms
OFF	5 – 12, 5 – 10, 5 – 12	Open circuit
UNLOCK	10 – 12	Less than 2 ohms

<Passenger's side>

SWITCH POSITION	TESTER CONNECTION	SPECIFIED CONDITION
LOCK	1 – 2	Less than 2 ohms
OFF	1 – 2, 2 – 3, 1 – 3	Open circuit
UNLOCK	2 – 3	Less than 2 ohms

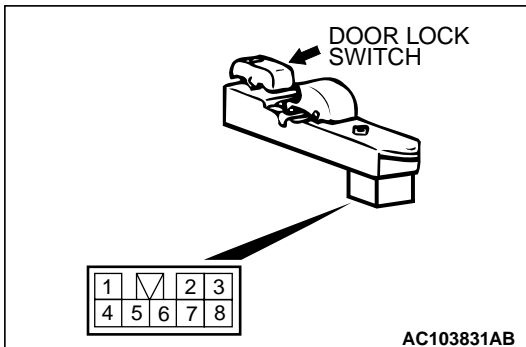
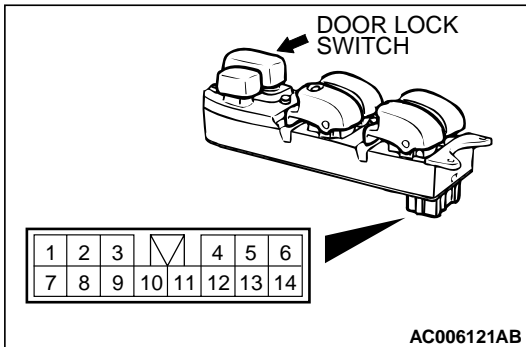

**WINDOW GLASS RUNCHANNEL AND DOOR OPENING WEATHERSTRIP
REMOVAL AND INSTALLATION**

M1423003100256

<FRONT DOOR>

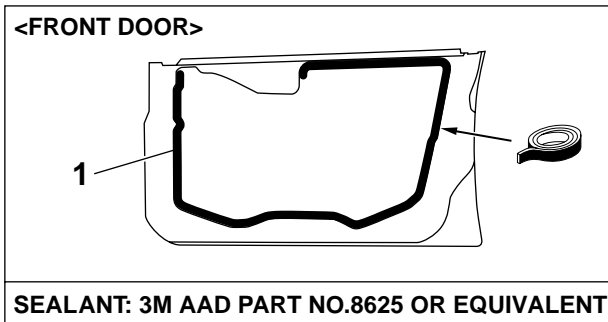
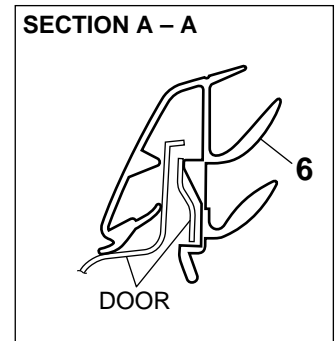
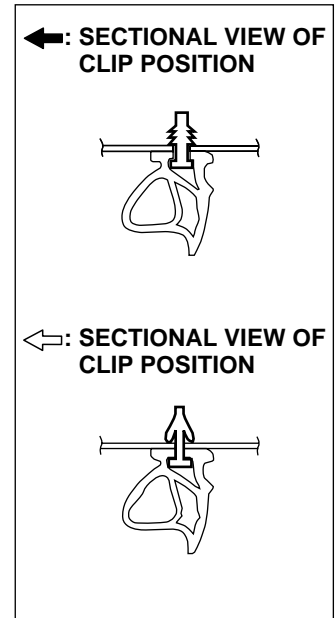
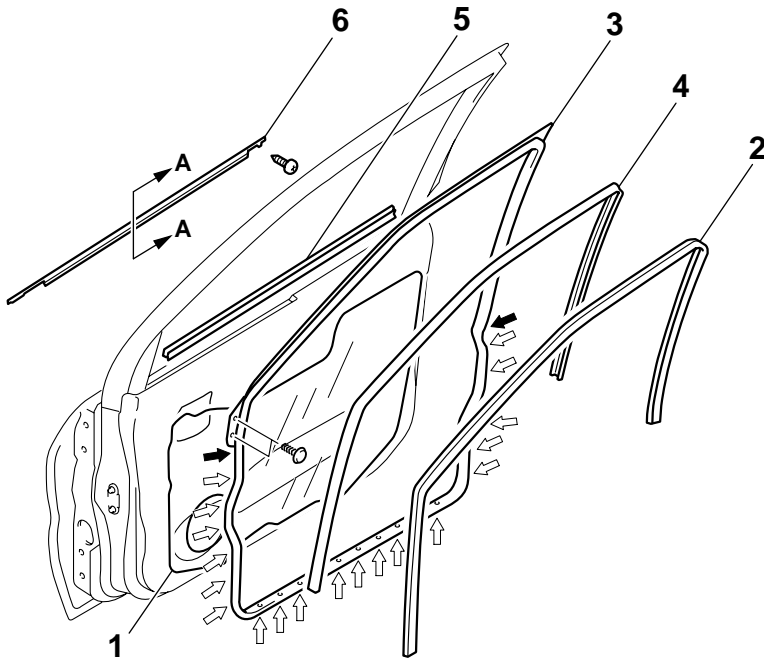

**WATERPROOF FILM REMOVAL
STEPS**

- DOOR TRIM ASSEMBLY (REFER TO GROUP 52A, TRIMS P.52A-11).
- SPEAKER (REFER TO GROUP 52A, TRIMS P.52A-11).

1. WATERPROOF FILM

**DOOR INNER OPENING
WEATHERSTRIP REMOVAL STEPS**

- SCUFF PLATE, CENTER PILLAR LOWER TRIM AND COWL SIDE TRIM (REFER TO GROUP 52A, TRIMS P.52A-11).

2. DOOR INNER OPENING WEATHERSTRIP (BODY SIDE)

**DOOR OUTER OPENING
WEATHERSTRIP REMOVAL STEPS**

- FRONT DOOR CHECK MOUNTING BOLT (DOOR SIDE) (REFER TO P.42-34).

<<A>> >>A<<

**DOOR OUTER OPENING
WEATHERSTRIP REMOVAL STEPS**

3. DOOR OUTER OPENING WEATHERSTRIP

**DOOR WINDOW GLASS
RUNCHANNEL REMOVAL**

4. DOOR WINDOW GLASS RUNCHANNEL

**DOOR BELTLINE INNER
WEATHERSTRIP REMOVAL STEPS**

- FRONT DOOR TRIM (REFER TO G52A, DOOR TRIM P.52A-13).

5. DOOR BELTLINE INNER WEATHERSTRIP

**DOOR BELTLINE MOULDING
REMOVAL STEPS**

- DOOR MIRROR ASSEMBLY (REFER TO GROUP 51, DOOR MIRROR P.51-32).
 - DOOR WINDOW GLASS (REFER TO P.42-36).
6. DOOR BELTLINE MOULDING

AC212058 AB

<REAR DOOR>

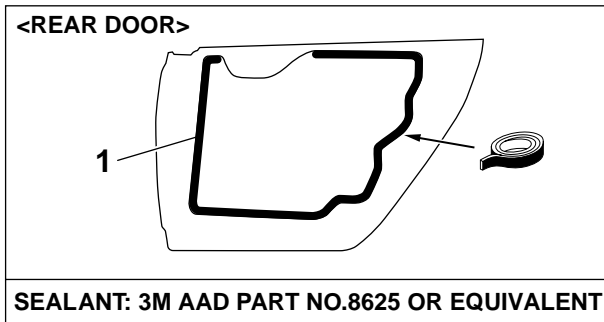
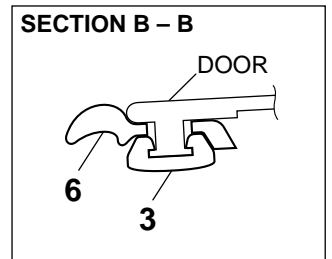
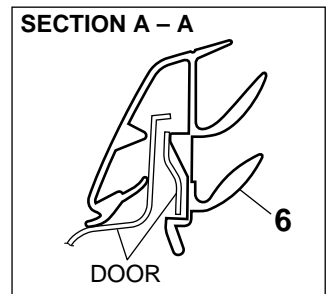
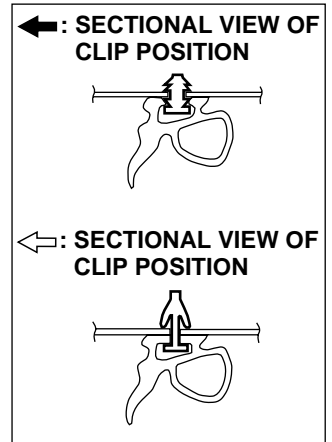
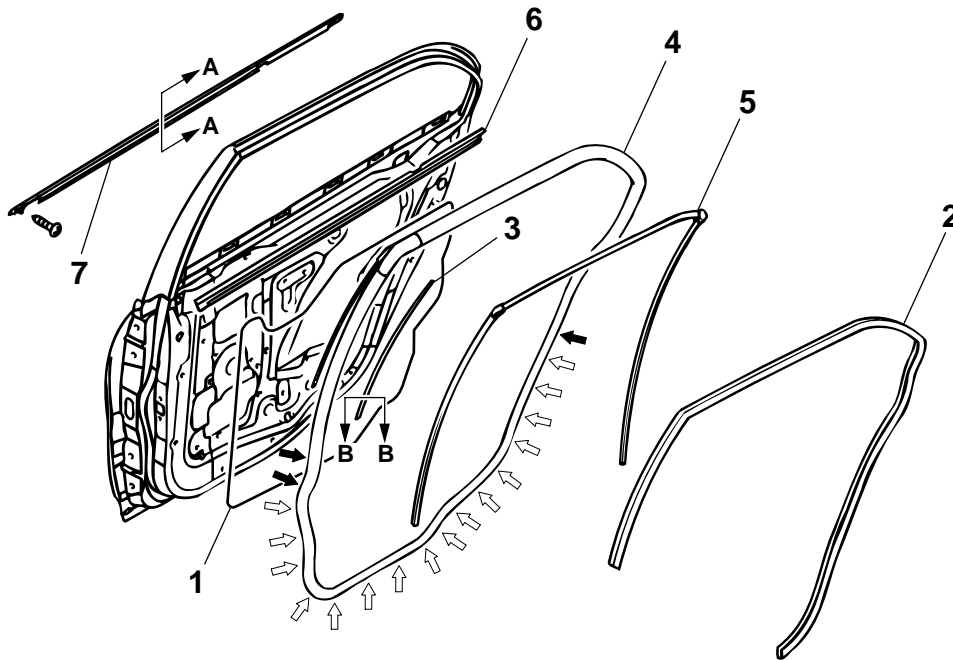

AC212072 AB

WATERPROOF FILM REMOVAL STEPS

1. WATERPROOF FILM

DOOR INNER OPENING

WEATHERSTRIP REMOVAL STEPS

- SCUFF PLATE, CENTER PILLAR LOWER TRIM AND COWL SIDE TRIM (REFER TO GROUP 52A, TRIMS P.52A-11).

2. DOOR INNER OPENING WEATHERSTRIP (BODY SIDE)

DOOR OUTER OPENING

WEATHERSTRIP REMOVAL STEPS

- REAR DOOR CHECK MOUNTING BOLT (DOOR SIDE) (REFER TO P.42-34).

3. RETAINER WEATHERSTRIP

- <<A>> >>A<<
4. DOOR OUTER OPENING WEATHERSTRIP

DOOR WINDOW GLASS RUNCHANNEL REMOVAL

5. DOOR WINDOW GLASS RUNCHANNEL

DOOR BELTLINE INNER

WEATHERSTRIP REMOVAL STEPS

- REAR DOOR TRIM (REFER TO GROUP 52A, DOOR TRIM P.52A-13).
- CENTER SASH UPPER (REFER TO P.42-36).

6. DOOR BELTLINE INNER WEATHERSTRIP

DOOR BELTLINE MOULDING REMOVAL STEPS

- DOOR WINDOW GLASS (REFER TO P.42-36).
- STATIONARY GLASS (REFER TO P.42-36).
- 7. DOOR BELTLINE MOULDING

REMOVAL SERVICE POINT

<<A>> DOOR OUTER OPENING WEATHERSTRIP REMOVAL

Make a fabricated tool as shown in the illustration to remove the door weatherstrip.

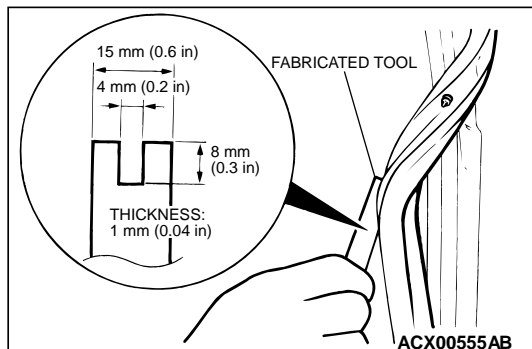

INSTALLATION SERVICE POINT

>>A<< DOOR OUTER OPENING WEATHERSTRIP INSTALLATION

The clip color identifies the left and right weatherstrips so be sure to use the colors so as to install correctly.

APPLICABLE SIDE	IDENTIFICATION COLOR
Right door	Pink
Left door	Natural (White)

TRUNK LID

TRUNK LID DIAGNOSIS

INTRODUCTION TO TRUNK LID DIAGNOSIS

Difficult locking and unlocking, uneven clearance and height, and generation of wind noise from the trunk lid may be caused by improper adjustment of the trunk lid.

M1421005800352

TRUNK LID DIAGNOSTIC TROUBLESHOOTING STRATEGY

Use these steps to plan your diagnostic strategy. If you follow them carefully, you will be sure that you have exhausted most of the possible ways to find a trunk lid fault.

1. Gather information from the customer.

2. Verify that the condition described by the customer exists.
3. Find the malfunction by following the Symptom Chart.
4. Verify malfunction is eliminated.

M1421005900326

SYMPTOM CHART

M1421006000360

SYMPTOM	INSPECTION PROCEDURE	REFERENCE PAGE
Difficult locking and unlocking	1	P.42-48
Uneven body clearance	2	P.42-48
Uneven height	3	P.42-48

SYMPTOM PROCEDURES

INSPECTION PROCEDURE 1: Difficult Locking and Unlocking

DIAGNOSIS

STEP 1. Check the release cable routing condition.

Q: Is the release cable routing condition good?

YES : Go to Step 3.

NO : Repair the release cable, then go to Step 2.

STEP 2. Check the engagement of the trunk lid latch and trunk lid striker.

Q: Are the trunk lid latch and trunk lid striker engaged correctly?

YES : Adjust the trunk lid striker. Refer to [P.42-50](#).

NO : Then go to Step 3.

STEP 3. Retest the system.

Q: Does the trunk lid lock operate easily?

YES : The procedure is complete.

NO : Return to Step 1.

INSPECTION PROCEDURE 2: Uneven Body Clearance

DIAGNOSIS

STEP 1. Check the clearance around the trunk lid.

Q: Are the apertures between the trunk lid and the adjacent body panels aligned correctly?

YES : Adjust the trunk lid panel assembly. Refer to [P.42-50](#).

NO : Then go to Step 2.

STEP 2. Retest the system.

Q: Are the clearances between the body panels even?

YES : The procedure is complete.

NO : Return to Step 1.

INSPECTION PROCEDURE 3: Uneven Height

DIAGNOSIS

STEP 1. Check the trunk lid bumper height.

Q: Is the trunk lid bumper height proper?

YES : Adjust the trunk lid bumper. Refer to [P.42-51](#).

NO : Then go to Step 2.

STEP 2. Retest the system.

Q: Are the trunk lid and body height even?

YES : The procedure is complete.

NO : Return to Step 1.

SPECIAL TOOL

M1421000600193

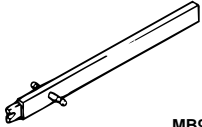
TOOL	TOOL NUMBER	NAME	APPLICATION
 MB991244	MB991244	Torsion bar remover and installer	Removal and installation of trunk lid torsion bar

ON-VEHICLE SERVICE

TRUNK LID ADJUSTMENT

M1421001000031

1. If the clearance around the trunk lid panel assembly is not uniform and locking and unlocking of the trunk lid is difficult, make adjustments to the trunk lid bumpers (refer to [P.42-50](#)) and trunk lid hinges (refer to [P.42-50](#)).
2. If the clearance around the trunk lid panel assembly is uniform, but locking and unlocking of the trunk lid is difficult, make adjustments to the trunk lid bumpers (refer to [P.42-50](#)) and trunk lid striker (refer to [P.42-50](#)).
3. If there is a difference in height between the side outer panels and the side edges of the trunk lid panel assembly, check the trunk lid hinges and, if necessary, replace them

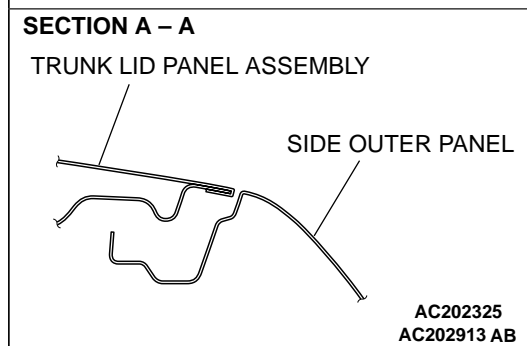
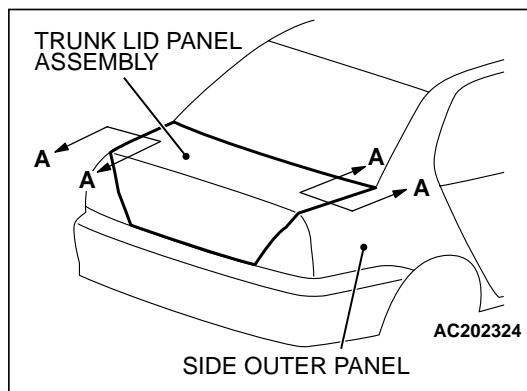

4. If the clearance around the trunk lid panel assembly is not uniform, and the trunk lid can be locked and unlocked smoothly, make adjustments to the trunk lid bumpers (refer to [P.42-50](#)) and trunk lid hinges (Refer to [P.42-50](#)).
5. If the locking and unlocking of the trunk lid still is difficult after making the above adjustments, adjust the trunk lid striker (Refer to [P.42-50](#)).

ADJUSTMENT OF CLEARANCE AROUND TRUNK LID

M1421008100028

Loosen the trunk lid panel assembly mounting bolts and move the trunk lid panel assembly to make the clearance around the trunk lid uniform

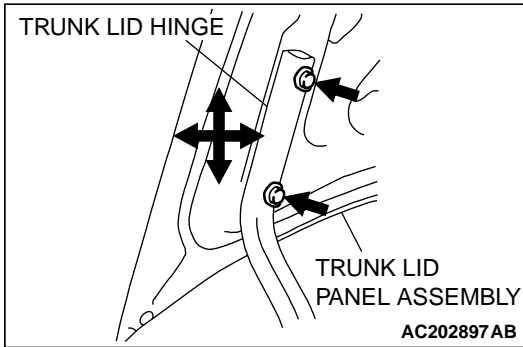

TRUNK LID STRIKER ADJUSTMENT

M1421008200025

After checking the trunk lid release cable for proper routing, loosen the trunk lid striker mounting bolts. Change the position of the trunk lid striker relative to the trunk lid latch assembly so that trunk lid locking and unlocking effort is correct

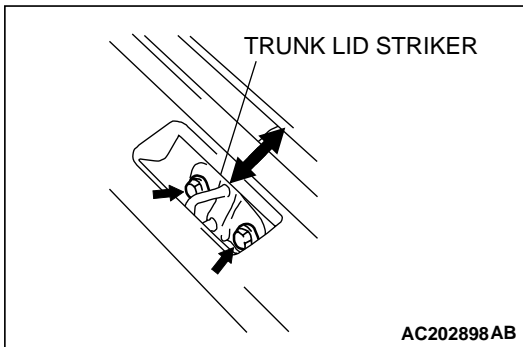

TRUNK LID HEIGHT ADJUSTMENT

M1421008300022

Turn each trunk lid bumper until the height shown in the drawing is reached. If the trunk lid panel height on one side is different from that on the other side (even after the trunk lid bumpers have been adjusted to the height indicated in the drawing), turn the trunk lid bumper(s) slightly to make fine adjustments to the trunk lid panel height

NOTE: When the bumper is new, one full turn of the trunk lid bumper changes the height approximately 3 mm. Turn it clockwise to reduce height. Turn it counterclockwise to increase height

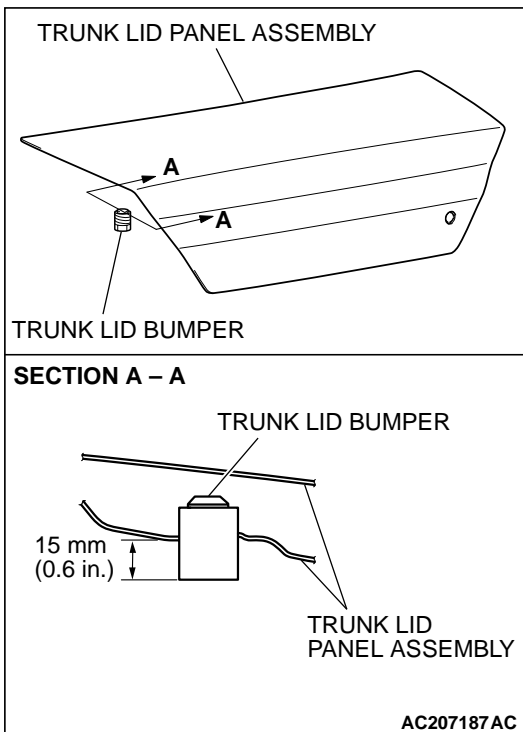

TRUNK LID
REMOVAL AND INSTALLATION

M1421002200179

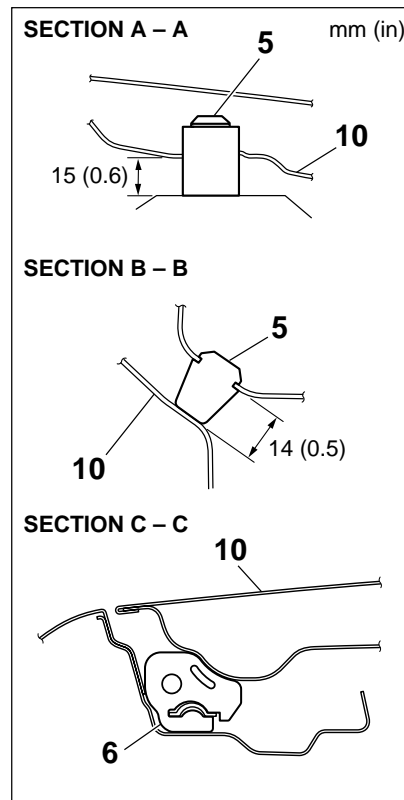
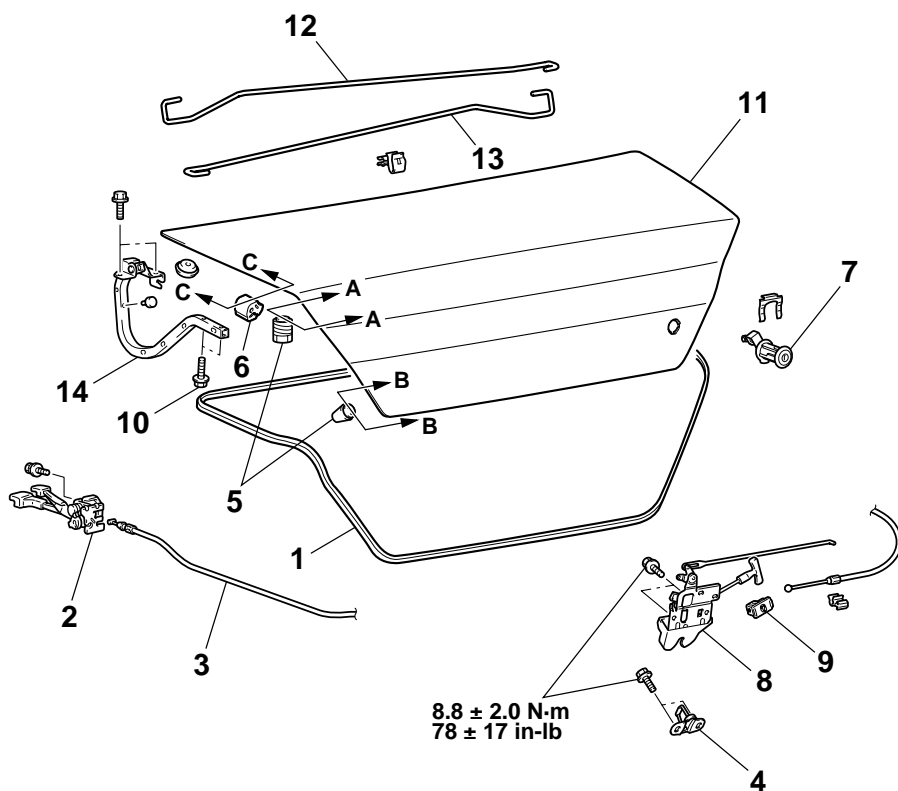

AC212008 AB

**TRUNK LID WEATHERSTRIP
REMOVAL STEPS**

- REAR END TRIM (REFER TO GROUP 52A, TRIM P.52A-11).

>>B<< 1. TRUNK LID WEATHERSTRIP
**TRUNK LID RELEASE CABLE AND
TRUNK LID RELEASE HANDLE
REMOVAL STEPS**

- TRUNK REAR SIDE TRIM (LH) (REFER TO GROUP 52A, TRIM P.52A-11).
 - REAR SEAT (REFER TO GROUP 52A, SEAT P.52A-22).
 - CENTER PILLAR LOWER TRIM (REFER TO GROUP 52A, TRIM P.52A-11).
 - COWL SIDE TRIM (REFER TO GROUP 52A, TRIM P.52A-11).
 - ACCELERATOR PEDAL STOPPER (REFER TO GROUP 17, ACCELERATOR PEDAL P.51-8).
2. TRUNK LID RELEASE HANDLE
 3. TRUNK LID RELEASE CABLE

<<A>> >>A<<
<<A>> >>A<<

**TRUNK LID STRIKER REMOVAL
STEPS**

- REAR END TRIM (REFER TO GROUP 52A, TRIM P.52A-11).

4. TRUNK LID STRIKER

TRUNK LID PANEL REMOVAL STEPS

5. TRUNK LID BUMPER
6. DAMPER
7. TRUNK LID LOCK CYLINDER
8. TRUNK LID LATCH ASSEMBLY
9. HANDLE HOLDER
10. TRUNK LID HINGE MOUNTING BOLT

11. TRUNK LID PANEL ASSEMBLY

TRUNK LID LATCH REMOVAL

7. TRUNK LID LATCH ASSEMBLY

TRUNK LID HINGE REMOVAL STEPS

- REAR SHIELD TRIM (REFER TO GROUP 52A, TRIM P.52A-11).
 - REAR SEAT (REFER TO GROUP 52A, SEAT P.52A-22).
11. TRUNK LID PANEL ASSEMBLY
 12. TRUNK LID TORSION BAR (LH)
 13. TRUNK LID TORSION BAR (RH)
 14. TRUNK LID HINGE

GREASE APPLICATION AREA

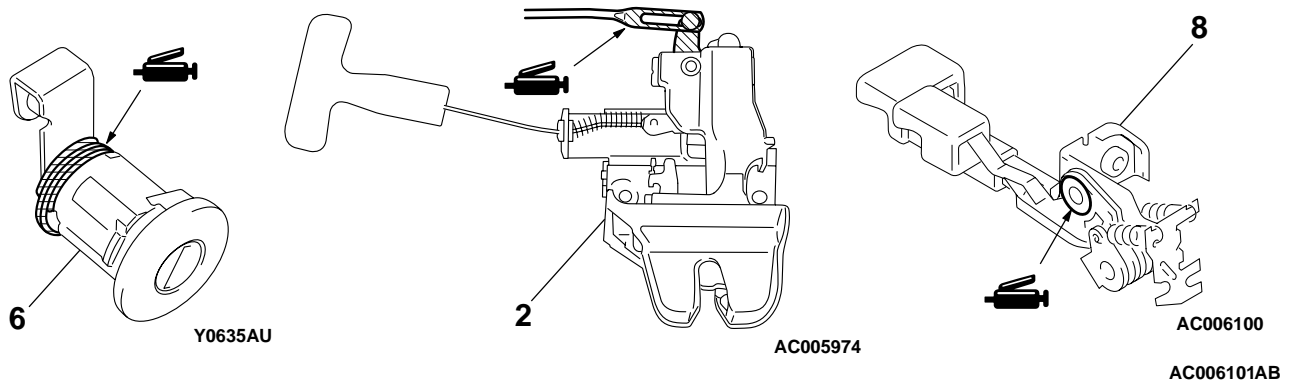

REMOVAL SERVICE POINT

<<A>> TRUNK LID TORSION BAR REMOVAL

1. Attach the special tool to the illustrated portion of the trunk lid torsion bar <LH> on the right hand of the vehicle, then use the tool to detach the trunk lid torsion bar <LH> from the trunk lid hinge <RH>
2. Remove the trunk lid torsion bar <RH> in the same way as the trunk lid torsion bar <LH>.

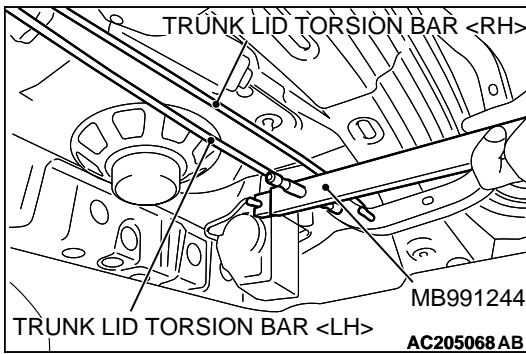

INSTALLATION SERVICE POINTS

>>A<< TRUNK LID TORSION BAR INSTALLATION

Install the trunk lid torsion bars using the following procedure.

CAUTION

Install the trunk lid torsion bar <RH> before the trunk lid torsion bar <LH>. If the sequence is reversed, the trunk lid torsion bar <RH> will not be able to be installed because the special tool will interfere with the trunk lid torsion bar <LH> during installation of the trunk lid torsion bar <RH>.

1. Identify the LH and RH torsion bars by the color mark made at the center of each torsion bar.

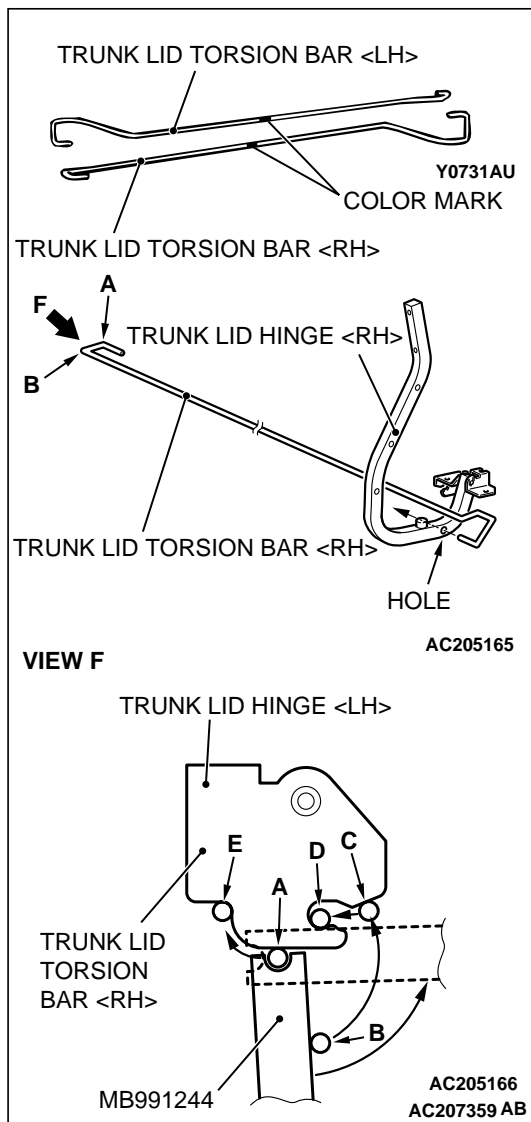

TRUNK LID TORSION BAR		MARK COLOR
LH	Vehicles with rear spoiler <TYPE A>	Green
	Vehicles with rear spoiler <TYPE B>	Sky blue
	Vehicles without rear spoiler	No mark
RH	Vehicles with rear spoiler <TYPE A>	Yellow
	Vehicles with rear spoiler <TYPE B>	White
	Vehicles without rear spoiler	Red

2. Insert the right end of the trunk lid torsion bar <RH> in the hole in the trunk lid hinge <RH>.
3. Press portion A of the trunk lid torsion bar <RH> left end against point A on the trunk lid hinge <LH> as shown in View F in the drawing.
4. Twist the portion B of the trunk lid torsion bar <RH> left end using the special tool until it is moved from point B and pressed against point C of the trunk lid hinge <LH> as shown in View F. Then force the portion into point D.
5. Twist the portion A of the trunk lid torsion bar <RH> left end until it reaches point E on the trunk lid hinge <LH> as shown in View F.
6. Attach the trunk lid torsion bar <LH> to the trunk lid hinge <RH> using the same method as the trunk lid torsion bar <RH>.

>>B<< TRUNK LID WEATHERSTRIP INSTALLATION

Install the trunk lid weatherstrip so that the marking and the joint are aligned with the body center line,

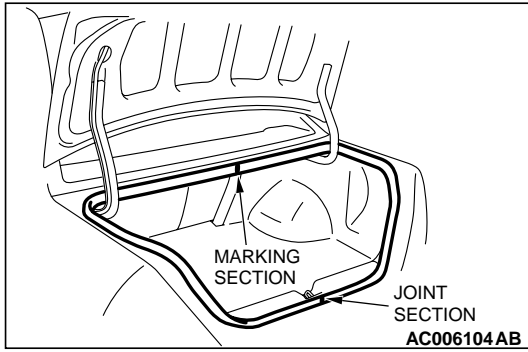

INSPECTION

M1421004800122

TRUNK LID LATCH SWITCH CONTINUITY CHECK

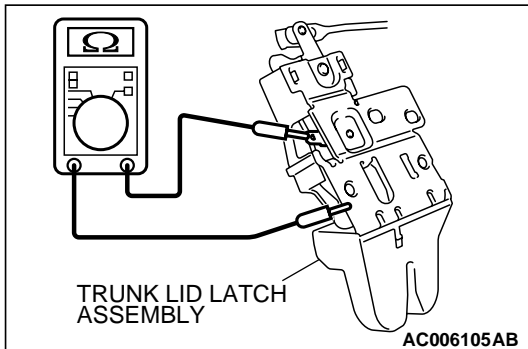

SWITCH POSITION	TESTER CONNECTION	SPECIFIED CONDITION
ON (Latch open)	1 – Ground	Less than 2 ohms
OFF (Latch shut)	–	Open circuit

KEYLESS ENTRY SYSTEM

GENERAL DESCRIPTION

M1428000100207

Some models are equipped with a radio-controlled keyless entry system. The main features are:

- Antenna and receiver are incorporated in the ETACS-ECU.
- ID code can be registered by using the scan tool (MUT-II).
- Transmitter is a key holder type, which incorporates lock switch and unlock switch.

- The locking is answered back by two times' flashing of the room lamp, two times' flashing of the turn signal lamp and one time sounding of the horn answerback.
- The unlocking is answered back by illuminating of the room lamp for 15 seconds and one time flashing of the turn signal lamp.

KEYLESS ENTRY SYSTEM DIAGNOSIS

M1428000700232

The keyless entry system is controlled by the Simplified Wiring System (SWS). For troubleshooting, refer to GROUP 54B, Diagnosis [P.54B-22](#).

SPECIAL TOOLS

M1428000600224

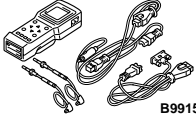
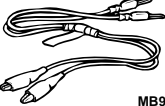
TOOL	TOOL NUMBER AND NAME	SUPERSESION	APPLICATION
	MB991502 Scan tool (MUT-II)	DRB-III scan tool	For registration of secret code
	MB991529 Diagnostic trouble code check harness	MB991529	For setting of hazard answerback function

ON-VEHICLE SERVICE

HOW TO REPLACE THE TRANSMITTER BATTERY

M1428000900195

⚠ CAUTION

Do not allow water or dust to enter the inside of the transmitter when it is open. Also, do not touch the precision electronic device.

1. Remove the set screw to remove the battery from the transmitter.
2. Install a battery with its (+) side face-down.

Battery required for replacement: Coin type battery CR2032

3. Insert the claw first, and assemble the transmitter.
4. Verify that the keyless entry system operates.

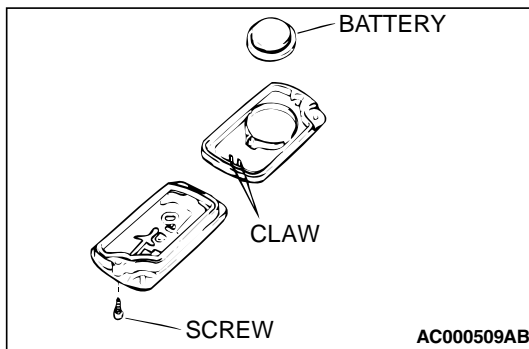

KEYLESS ENTRY SYSTEM TIMER LOCK FUNCTION INSPECTION

M1428004000075

Unlock the transmitter and check to see that the doors lock within 30 seconds. If it doesn't, then execute troubleshooting remedies. Refer to GROUP 54B, Diagnosis [P.54B-6](#).

ENABLING/DISABLING THE ANSWERBACK FUNCTION

M1428003200173

If the keyless entry system locks or unlocks the doors, the dome light flashes or illuminates, the hazard warning light flashes (hazard answerback function) and the horn sounds (horn answerback function). The hazard and horn answerback functions can be enabled or disabled according to the following procedure:

**ENABLING/DISABLING THE HAZARD
ANSWERBACK FUNCTION**

The hazard answerback function can be enabled or disabled by one of the two following procedures.

<When the transmitter is used after connecting scan tool MB991502 to the data link connector or grounding data link connector terminal (1)>

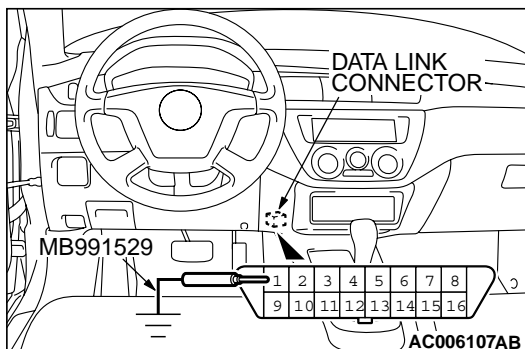
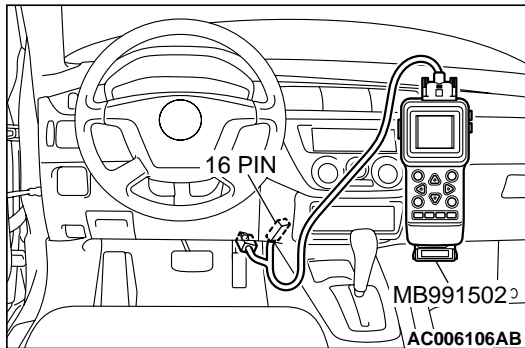

1. Enter the hazard answerback customize mode by observing one of the following steps. If the ETACS-ECU enters the customize mode, its tone alarm will sound once.
 - (1) Turn the ignition switch to "LOCK"(OFF) position.
 - (2) Turn off the hazard warning light switch.
 - (3) Connect scan tool MB991502 to the data link connector terminal (1).
 - (4) Close the driver's side door.
 - (5) Leave the windshield washer switch on for at least ten seconds. Then the ETACS-ECU tone alarm will sound once.
2. If the transmitter "LOCK" button is pushed consecutively twice (within two seconds), the ETACS-ECU tone alarm will sound, indicating that the hazard answerback function can be enabled or disabled when the doors are locked.
 - **Enable the hazard answerback function when the doors are locked: The ETACS-ECU tone alarm will sound once.**
 - **Disable the hazard answerback function when the doors are locked: The ETACS-ECU tone alarm will sound twice.**
3. If the transmitter "UNLOCK" button is pushed consecutively twice (within two seconds), the ETACS-ECU tone alarm will sound, indicating that the hazard answerback function can be enabled or disabled when the doors are unlocked.
 - **Enable the hazard answerback function when the doors are unlocked: The ETACS-ECU tone alarm will sound once.**
 - **Disable the hazard answerback function when the doors are unlocked: The ETACS-ECU tone alarm will sound twice.**
4. Exit the hazard answerback customize mode by observing one of the following steps.
 - (1) Disconnect scan tool MB991502 from the data link connector, or disconnect data link connector terminal (1) from the ground.

- (2) Turn the ignition switch to position other than "LOCK"(OFF), or remove the ignition key.
- (3) Open the driver's side door,
- (4) Any other warning tone alarm output occurs

NOTE: If any operation is not done for at least three minutes after the ETACS-ECU has entered the customize mode, the hazard answerback customize mode will be canceled automatically.

<When only the transmitter is used>

1. Remove the ignition key.
2. Push the "LOCK" button while holding the "UNLOCK" button pushed for four to ten seconds.
3. If the "LOCK" button and "UNLOCK" button are released in that order, the ETACS-ECU tone alarm will sound, indicating that the hazard answerback function can be enabled or disabled when the doors are locked.
 - **Enable the hazard answerback function when the doors are locked: The ETACS-ECU tone alarm will sound once.**
 - **Disable the hazard answerback function when the doors are locked: The ETACS-ECU tone alarm will sound twice.**
4. If the "UNLOCK" button and "LOCK" button are released in that order, the ETACS-ECU tone alarm will sound, indicating that the hazard answerback function can be enabled or disabled when the door are unlocked.
 - **Enable the hazard answerback function when the doors are unlocked: The ETACS-ECU tone alarm will sound once.**
 - **Disable the hazard answerback function when the doors are unlocked: The ETACS-ECU tone alarm will sound twice.**

**ENABLING/DISABLING THE HORN
ANSWERBACK FUNCTION**

<When only the transmitter is used>

1. Remove the ignition key.
2. Push the "UNLOCK" button while holding the "LOCK" button pushed for four to 10 seconds.
3. If the "LOCK" button and "UNLOCK" button are released at the same time, the ETACS-ECU tone alarm will sound, indicating that the horn answerback function can be enabled or disabled.
 - **Enable the horn answerback function: The ETACS-ECU tone alarm will sound once.**
 - **Disable the horn answerback function: The ETACS-ECU tone alarm will sound twice.**

4. If the “LOCK” button and “UNLOCK” button are released at the same time, the ETACS-ECU tone alarm will sound, indicating that the horn answerback function can be enabled or disabled.
- **Enable the horn answerback function*:** The ETACS-ECU tone alarm will sound once.
 - **Disable the horn answerback function:** The ETACS-ECU tone alarm will sound twice.
 - **Enable the horn answerback function**:** The ETACS-ECU tone alarm will sound three times.

NOTE:

*: The horn will sound if the doors are locked with the keyless entry system.

** : The horns sound when the other doors are locked by the keyless entry system with some door(s) has been locked.

HOW TO REGISTER SECRET CODE

M1428001000236

Each individual secret code is registered inside the transmitter, and so it is necessary to register these codes with the EEPROM inside the receiver in the following cases.

- When the transmitter or ETACS-ECU is replaced
- If more transmitters are to be used
- If it appears that a problem is occurring because of faulty registration of a code.

A maximum of four different codes can be stored in the EEPROM memory (four different transmitters can be used). When the code for the first transmitter is registered, the previously registered codes for all transmitters are cleared. Therefore, if you are using four transmitters or are adding more transmitters, the codes for all transmitters must be registered at the same time.

1. Check that the doors lock normally when the key is used.
2. Insert the ignition key.

⚠ CAUTION

To prevent damage to scan tool MB991502, always turn the ignition switch to “LOCK” (OFF) position before connecting or disconnecting scan tool MB991502.

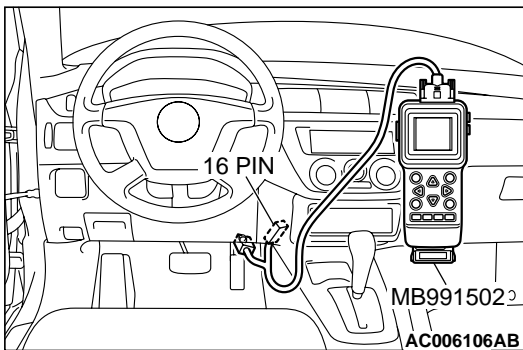

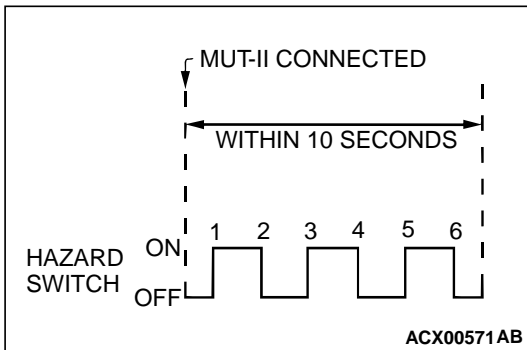
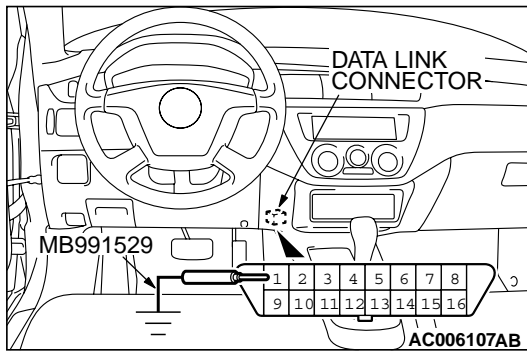

3. Connect the scan tool to the data link connector. If the scan tool is not used, ground terminal (1) of the data link connector.
NOTE: This will connect terminal (1) of the data link connector to ground, and the system will be in secret code registration standby mode.
4. Press the hazard switch six times within 10 seconds.
NOTE: At this time the code registration monitor request is output (all doors locked and unlocked) and becomes registration mode.
NOTE: The hazard warning light switch is turned on and off alternately whenever it is pushed.
5. Press the transmitter button, and then press it two times within 10 seconds of the first press. This will register the code.
6. When registration is completed, the code registration monitor request is output (all doors locked and unlocked).
7. If you are using two or more transmitters or have added a second transmitter, the same registration procedure should be carried out within one minute after registering the code for the first transmitter. After the second registration is completed, the code registration monitor request is output (all doors locked and unlocked).
8. Registration mode will be canceled under the following conditions:
 - When the secret code for four transmitters has been registered;
 - When one minute has been passed after registration mode started;
 - When scan tool MB991502 is disconnected (the ground connection is broken);
 - When the key is removed from the key cylinder;
9. After the registration is completed, carry out the following work, and then check that the keyless entry system operates normally.
 - Remove the ignition key.
 - Close all of the doors.

SUNROOF ASSEMBLY

GENERAL DESCRIPTION

A motor-driven outer slide-type glass sunroof with a tilt-up mechanism is adopted in some models as optional equipment. Even when the sunroof is

fully closed, a sufficient amount of light and a feeling of openness can still be obtained by opening the sunroof sunshade.

M1426000100201

SUNROOF DIAGNOSIS





The sunroof system is controlled by the Simplified Wiring System (SWS). For troubleshooting,

refer to GROUP 54B, Diagnosis [P.54B-6](#).

M1426000700247

SPECIAL TOOLS

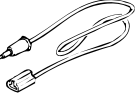
M1426000600206

TOOL	TOOL NUMBER AND NAME	SUPER SESSION	APPLICATION
     MB991223AD	MB991223 Harness set <ul style="list-style-type: none"> • A: MB991219 Test harness • B: MB991220 LED harness • C: MB991221 LED harness adapter • D: MB991222 Probe 	MB991223	Measurement of terminal voltage <ul style="list-style-type: none"> • A: Connector pin contact pressure inspection • B: Power circuit inspection • C: Power circuit inspection • D: Commercial tester connection

ON-VEHICLE SERVICE

WATER TEST

M1426000900229

Check if there are any leaks in the sunroof by the following procedure.

1. Fully close the roof lid glass.
2. Adjust the water pressure so that water comes out of the hose to a height of approximately 50 cm (19.7 inches) when the hose is held vertically facing upwards.
3. Hold the end of the hose approximately 30 cm (11.8 inches) above the roof and let the water run onto the weatherstrip for 5 minutes or more.
4. Check if any water leaks can be found in the room while watering. Even though there are any water leaks around the roof lid glass, it can be acceptable as long as water is caught in the drip area.

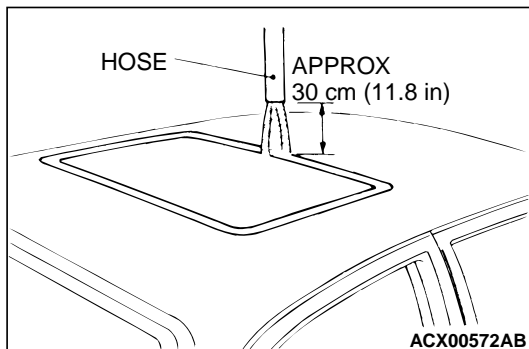

SUNROOF TIMER FUNCTION CHECK

M1426004300070

Keep the door closed, turn OFF the ignition switch and check to see if the sunroof operates for 30 seconds after that. If operations malfunction then execute troubleshooting remedies (Refer to GROUP 54B, Diagnosis P.54B-6).

SUNROOF FIT ADJUSTMENT

M1426001000230

1. Fully close the roof lid glass.
2. Fully open the sunshade.
3. Loosen the screws fixing the roof lid glass assembly, move the roof lid glass assembly along the long hole of the drive cable assembly, adjust the height of the roof lid glass, and check that the space between the roof lid glass and body is consistent along the whole circumference.
4. After adjusting, check that the sunroof operates smoothly.

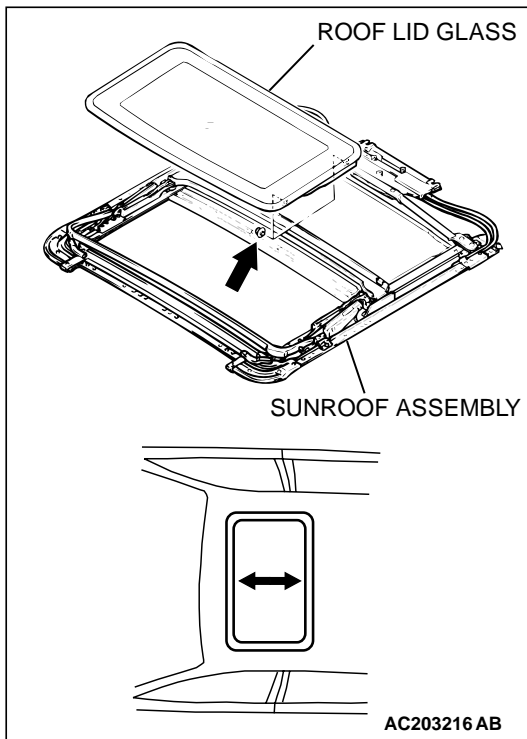

SUNROOF SAFETY FUNCTION CHECK

M1426004400088

1. Close the roof lid glass by applying an approximately 10mm (0.39 inch) thickness wood chip placed in a right angle with the roof lid glass.
2. Check to see if the roof lid glass opens after the motor turns when the roof lid glass catches the wooden chip (Refer to GROUP 54B, Diagnosis P.54B-6).

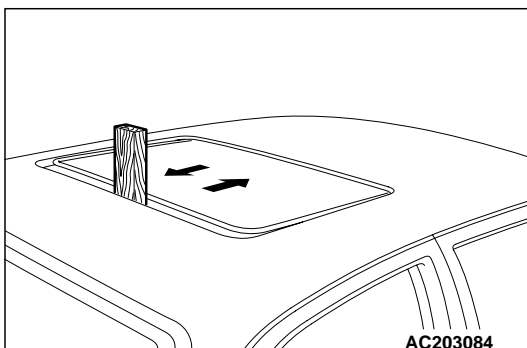

SUNROOF CHECK

M1426004700067

Check to see that the sunroof operates by pressing the sunroof switch. Execute troubleshooting remedies if operations malfunction. (Refer to GROUP 54B, Diagnosis P.54B-6.)

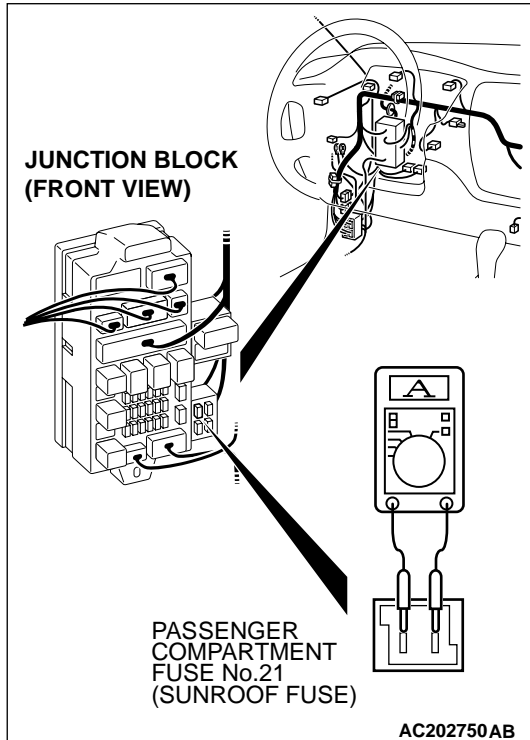

ROOF LID GLASS OPERATION CURRENT CHECK

M1426003200111

1. Remove the fuse of the sunroof then connect the circuit tester as shown in the Figure.
2. Turn ON the sunroof switch then measure the operating current of the intermediary segment when operations is starting, the sunroof is fully closed, the sunroof is fully opened and the sunroof is tilted fully up.

Standard value: 7 A or less [at 20 °C (68 °F)]

3. Check the following areas if the operating current of the roof lid glass exceeds the standard value.
 - Sunroof assembly assembling state, deformation and biting of any foreign substances.
 - Drive cable fastening
 - Tilting of roof lid glass

SUNROOF INITIALIZED ADJUSTMENT

M1426004600071

1. Assemble the roof lid glass assembly and sunroof motor assembly on the sunroof assembly.
2. Connect the sunroof motor assembly connector and sunroof switch connector to the wire ring harness connector on the vehicle side.
3. Fully open the roof lid glass by pressing the sunroof switch then fully close the sunroof by repeating to press the close switch.
4. Continuously press the close switch for a minimum of 3 seconds from the fully closed state.
5. Press the open switch to fully open the sunroof then press the close switch to fully close the sunroof.

NOTE: Do not stop the sunroof before the sunroof is fully opened or fully closed in Step 5, above. If the fully open or close operation is interrupted/stopped then start over from Step 3.

OPERATION CHECK

M1426002600279

Check that the following items. If faulty, replace the sunroof-ECU (sunroof motor assembly).

⚠ CAUTION

Check that the following items are normal before carrying out this operation check.

1. Installation condition of the sunroof assembly
2. Installation condition, deforms and attached foreign material of the sunroof drive cable
3. Unfitted sunroof lid glass
4. Sunroof switch and sunroof motor assembly

Basic operation

NO.	SUNROOF FUNCTION	REQUIREMENTS FOR THE SUNROOF TO FUNCTION	NORMAL OPERATION
01	OPEN	1. Ignition switch: ON 2. Sunroof switch: OPEN	The sunroof opens fully and automatically.
02	CLOSE	1. Ignition switch: ON 2. Sunroof switch: CLOSE/TILT-DOWN	The sunroof closes while the sunroof switch is pushed to the CLOSE/TILT-DOWN position.
03	TILT-UP	1. Ignition switch: ON 2. Sunroof switch: TILT-UP	The sunroof tilts up fully and automatically.
04	TILT-DOWN	1. Ignition switch: ON 2. Sunroof switch: CLOSE/TILT-DOWN	The sunroof closes while the sunroof switch is pushed to the CLOSE/TILT-DOWN position.
05	AUTOMATIC OPERATION INTERRUPTION	A 1. Ignition switch: ON 2. Sunroof switch: TILT-UP or CLOSE/TILT DOWN (Push the sunroof switch to the CLOSE/TILT-DOWN position while the sunroof is automatically opening and release the switch within two seconds)	The sunroof stops the automatic opening operation.
		B 1. Ignition switch: ON 2. Sunroof switch: CLOSE/TILT DOWN (Push the sunroof switch to the CLOSE/TILT-DOWN position more than two seconds while the sunroof is automatically opening)	The sunroof stops the automatic opening operation, and the sunroof closes while the sunroof switch is pushed to the CLOSE/TILT-DOWN position.

Jam preventing mechanism

NO.	SUNROOF FUNCTION	REQUIREMENTS FOR THE SUNROOF TO FUNCTION	NORMAL OPERATION
01	CLOSE	1. Ignition switch: ON 2. Sunroof switch: CLOSE/TILT-DOWN 3. Sunroof initial position: being closed or opened 4. Interrupt the sunroof operation before the sunroof is fully closed.	After you interrupts the sunroof operation, it opens by the predetermined distance and then stops automatically.
02	TILT-DOWN	1. Ignition switch: ON 2. Sunroof switch: CLOSE/TILT-DOWN 3. Sunroof initial position: being tilting down 4. Interrupt the sunroof operation before the sunroof is fully close.	The sunroof tilts up automatically after it is interrupted.

Sunroof timer mechanism

In cases except the followings, the basic operation and jam preventing mechanism will be maintained for thirty seconds after the ignition switch is turned to the LOCK (OFF) position. (Sunroof timer function)

- If you open a door within that period (i.e. a door switch is on), the sunroof timer function will be cancelled immediately.
- If you closes the sunroof fully while the timer is working, the sunroof timer function is cancelled after that sunroof operation.
- If you turns the ignition switch to the LOCK (OFF) position while the timer is working, the sunroof will continue moving until it closes fully regardless of the time-out period.

SUNROOF ASSEMBLY
REMOVAL AND INSTALLATION

M1426001200256

Post-installation Operation <Roof lid glass assembly, Sunroof assembly>

- Sunroof Water Test (Refer to P.42-60).
- Sunroof Fit Adjustment (Refer to P.42-61).
- Sunroof Initializing Adjustment (Refer to P.42-62).

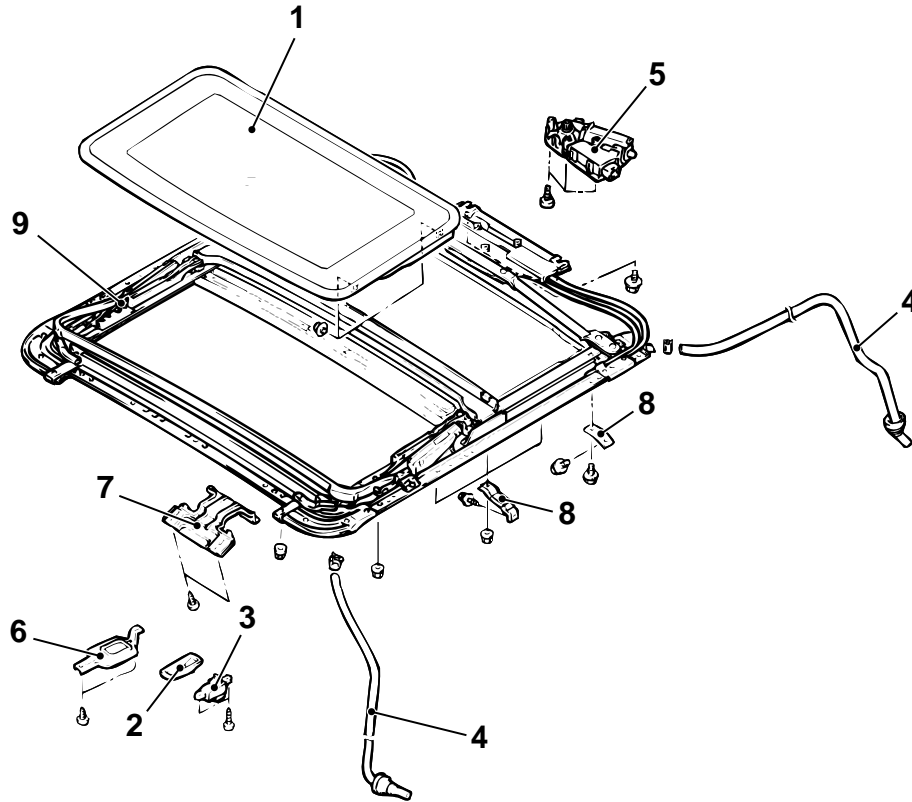

AC202751 AB

1. ROOF LID GLASS ASSEMBLY
SUNROOF SWITCH REMOVAL STEPS

2. SUNROOF SWITCH COVER
3. SUNROOF SWITCH

DRAIN PIPE REMOVAL STEPS

- SPLASH SHIELD (REFER TO P.42-9).
- HEADLINING (REFER TO GROUP 52A P.52A-18).

<<A>> >>A<<

4. DRAIN PIPE

SUNROOF MOTOR ASSEMBLY REMOVAL STEPS

- HEADLINING (REFER TO GROUP 52A P.52A-18).

>>B<<

5. SUNROOF MOTOR ASSEMBLY

SUNROOF ASSEMBLY REMOVAL STEPS

- HEADLINING (REFER TO GROUP 52A P.52A-18).

<<A>> >>A<<

4. DRAIN PIPE

6. SUNROOF SWITCH BRACKET

7. ROOM LAMP BRACKET

8. SET BRACKET

>>B<<

9. SUNROOF ASSEMBLY

Required Special Tool:

- MB991223: Harness set

INSTALLATION SERVICE POINTS**<<A>> DRAIN PIPE REMOVAL**

Tie a cord to the end of the drain pipe, and wind tape around it so that there is no unevenness. Then pull the drain pipe out to the wheel house side.

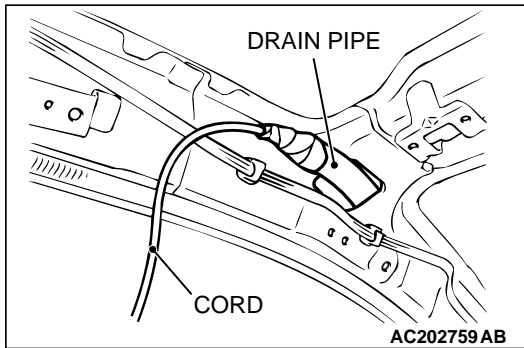
**<> SUNROOF ASSEMBLY REMOVAL**

Using round nose pliers or the like, turn the caulking the way shown in the illustration and then remove the sunroof assembly.

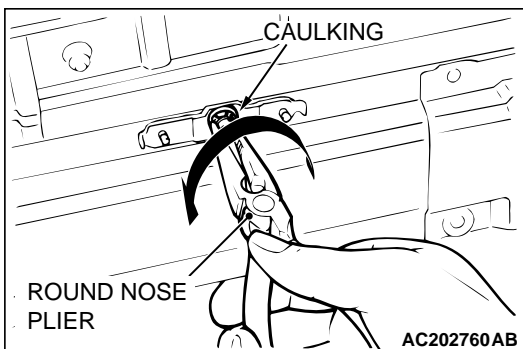
**INSTALLATION SERVICE POINTS****>>A<< DRAIN PIPE INSTALLATION**

1. Tie the cord that was used during removal to the end of the drain pipe, and wind tape around it so that there is no unevenness.
2. Pull the cord to pass through the drain pipe.
3. Install the grommet, and then position the drain pipe so that it protrudes from the grommet as shown in the illustration.

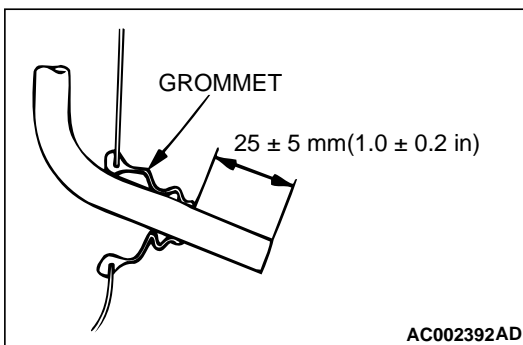
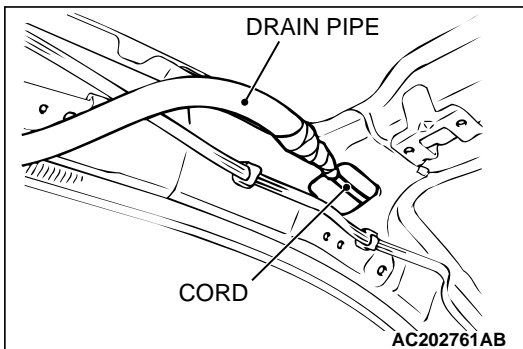

>>B<< SUNROOF MOTOR ASSEMBLY INSTALLATION

1. Install the roof lid glass assembly and the sunroof motor assembly with the sunroof assembly.
2. Connect the sunroof motor assembly connector and the sunroof switch connector to the vehicle wiring harness connector.
3. Operate the sunroof switch to slide the roof lid glass to the fully-open position, and then tilt it up in steps of 30 mm (1.18inch) to the fully-open position and then keep pressing the switch for 0.5 second or more.

NOTE: During initialization (learning mode), use only the CLOSE/OPEN switch to move the roof lid glass from the fully-closed position to the fully-open position. During initialization, the TILT UP switch will not work when pressed. Furthermore, the sunroof-ECU will stop running in learning mode as soon as the glass is titled up.

INSPECTION

M1421007600428

SUNROOF SWITCH CONTINUITY CHECK

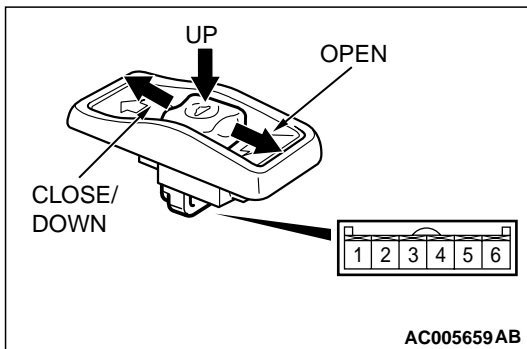

SWITCH POSITION	TESTER CONNECTION	SPECIFIED CONDITION
Open	4 – 5	Less than 2 ohms
Off	3 – 4, 4 – 5, 4 – 6	Open circuit
Tilt up	3 – 4	Less than 2 ohms
Slide closed, Tilt down	4 – 6	

DISASSEMBLY AND ASSEMBLY

M1426001400238

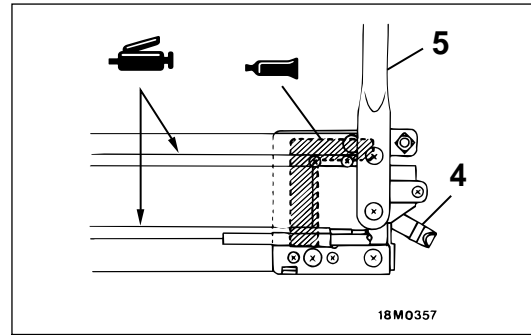
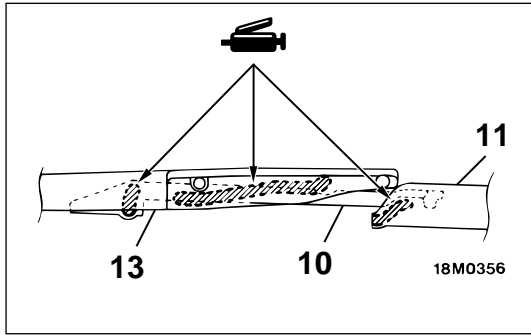

SEALANT: 3M™ AAD PART NO. 8531 OR EQUIVALENT

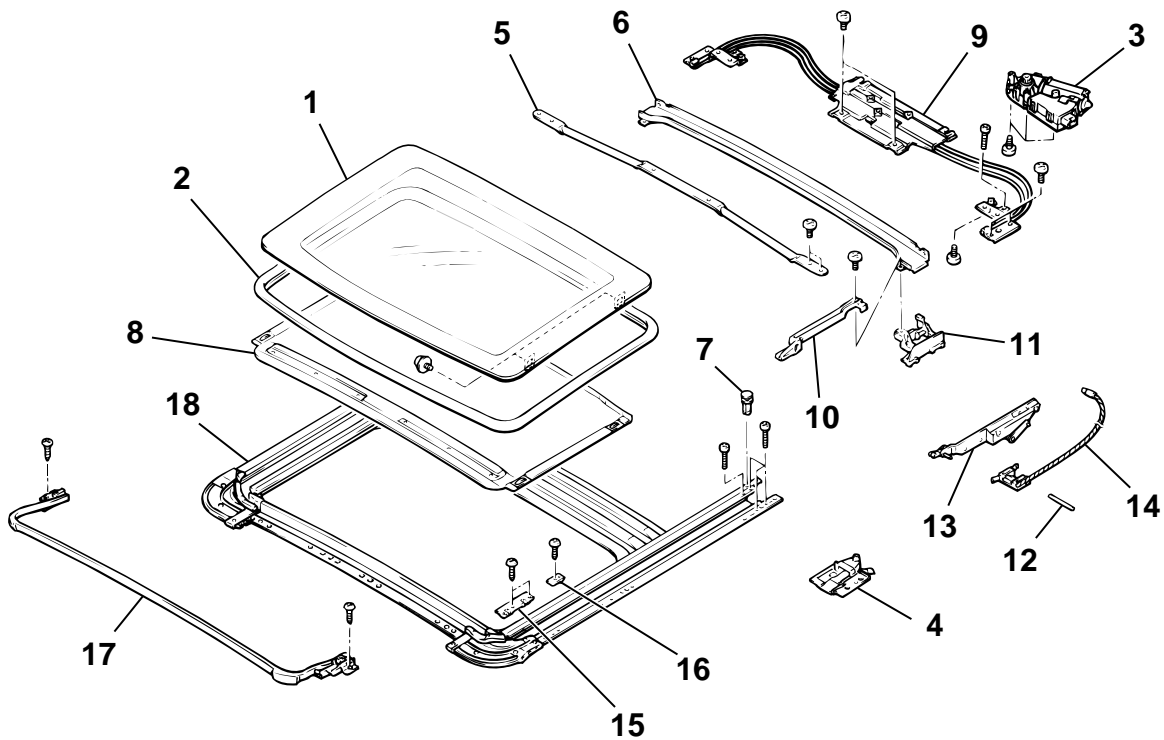

W0373AU

AC202752 AC

DISASSEMBLY STEPS

1. ROOF LID GLASS ASSEMBLY
2. WEATHERSTRIP
3. SUNROOF MOTOR ASSEMBLY
4. REAR DRIP
5. FRAME
6. DRIP RAIL ASSEMBLY
7. CLIP <LEFT SIDE ONLY>
8. SUN SHADE ASSEMBLY
9. DRIVE UNIT ASSEMBLY

DISASSEMBLY STEPS

10. DRIP LINK
11. DRIP SHOE ASSEMBLY
12. SHAFT
13. LIFTER ASSEMBLY
14. CABLE ASSEMBLY
15. SET PLATE
16. REAR SET PLATE
17. DEFLECTOR ASSEMBLY
18. FRAME ASSEMBLY

SPECIFICATIONS

FASTENER TIGHTENING SPECIFICATIONS

M1421005300186

ITEM	SPECIFICATION
Hood	
Hood hinge bolt (hood side)	11 ± 2 N·m (98 ± 17 in-lb)
Hood hinge bolt (body side)	21 ± 4 N·m (16 ± 2 in-lb)
Hood hinge nut (body side)	11 ± 2 N·m (98 ± 17 in-lb)
Hood latch bolt	9.0 ± 2.0 N·m (80 ± 17 in-lb)
Fuel filler lid	
Fuel filler lid bolt	5.0 ± 1.0 N·m (44 ± 9 in-lb)
Strut tower bar	
Strut tower bar bolt	44 ± 5 N·m (32 ± 4 in-lb)
Door	
Door check bolt (body side)	11 ± 2 N·m (98 ± 17 in-lb)
Door check bolt (door side)	5.0 ± 1.0 N·m (44 ± 9 in-lb)
Door hinge bolt (body side)	27 ± 5 N·m (20 ± 4 in-lb)
Door hinge bolt (door side)	21 ± 4 N·m (16 ± 2 in-lb)
Door outside handle bolt	5.0 ± 1.0 N·m (44 ± 9 in-lb)
Door latch assembly screw	9.0 ± 2.0 N·m (80 ± 17 in-lb)
Door switch screw	1.5 ± 0.5 N·m (14 ± 4 in-lb)
Striker screw	11 ± 2 N·m (98 ± 17 in-lb)
Trunk lid	
Trunk lid latch assembly bolt	8.8 ± 2.0 N·m (78 ± 17 in-lb)
Striker bolt	8.8 ± 2.0 N·m (78 ± 17 in-lb)

SERVICE SPECIFICATIONS

M1421000300233

<DOOR>

ITEM	STANDARD VALUE
Door inside handle play mm (in)	Front 2.3 ± 2.1 (0.09 ± 0.08)
	Rear 1.3 ± 1.7 (0.05 ± 0.07)
Door outside handle play mm (in)	Front 9.6 ± 9.2 (0.38 ± 0.36)
	Rear 9.0 ± 9.2 (0.35 ± 0.36)
Power window operation current A	5 ± 1 [Power supply voltage 14.5 ± 0.5V 25°C (77°F)]

<SUNROOF>

ITEM	STANDARD VALUE
Roof lid glass operation current A	7 or more [20°C (68°F)]

SEALANT AND ADHESIVES

M1421000500196

<DOOR>

ITEM	SPECIFIED SEALANT	REMARK
Waterproof film	3 M™ AAD Part No. 8633 or equivalent	Ribbon sealer

<WINDOW GLASS>

ITEM	SPECIFIED ADHESIVES
Rear window glass	3 M™ AAD Part No. 8609 Super Fast Urethane and 3 M™ AAD Part No. 8608 Super Fast Urethane Primer or equivalent
Windshield	

<SUNROOF>

ITEM	SPECIFIED ADHESIVES
Rear drip	3 M™ AAD Part No. 8531 or 8646 or equivalent

COMPONENT IDENTIFICATIONS

M1421005400235

<DOOR CHECK>

APPLICABLE LOCATION	IDENTIFICATION MARK	
LH	Front door	39L
	Rear door	40L
RH	Front door	39R
	Rear door	40R

<DOOR OUTER OPENING WEATHERSTRIP>

APPLICABLE SIDE	IDENTIFICATION COLOR
Left door	Natural (White)
Right door	Pink

<TRUNK LID TORSION BAR>

EQUIPMENT	IDENTIFICATION COLOR	
Vehicles without rear spoiler	LH	–
	RH	Red
Vehicles with rear spoiler	LH	Green
	RH	Yellow