

## GROUP 55

# HEATER, AIR CONDITIONING AND VENTILATION

## CONTENTS

<b>GENERAL DESCRIPTION</b> .....	<b>55-3</b>	RECEIVER DRIER TEST .....	55-71
<b>SERVICE PRECAUTIONS</b> .....	<b>55-4</b>	PRESSURE SWITCH CHECK .....	55-71
CAUTION LABELS .....	55-4	COMPRESSOR DRIVE BELT ADJUSTMENT .....	55-71
<b>MANUAL A/C DIAGNOSIS</b> .....	<b>55-5</b>	CHARGING .....	55-71
INTRODUCTION TO HEATER, AIR CONDITIONING AND VENTILATION DIAGNOSIS .....	55-5	PERFORMANCE TEST .....	55-72
HEATER, AIR CONDITIONING AND VENTILATION DIAGNOSTIC TROUBLESHOOTING STRATEGY .....	55-5	REFRIGERANT LEAK REPAIR PROCEDURE .....	55-73
SYMPTOM CHART .....	55-5	COMPRESSOR NOISE CHECK .....	55-74
SYMPTOM PROCEDURES .....	55-6	POWER RELAY CHECK .....	55-74
CHECK AT ECU TERMINAL .....	55-69	IDLE-UP OPERATION CHECK .....	55-75
<b>SPECIAL TOOLS</b> .....	<b>55-70</b>	<b>HEATER CONTROL ASSEMBLY AND A/C SWITCH</b> .....	<b>55-76</b>
<b>ON-VEHICLE SERVICE</b> .....	<b>55-70</b>	REMOVAL AND INSTALLATION .....	55-76
REFRIGERANT LEVEL TEST .....	55-70	INSPECTION .....	55-77
A/C COMPRESSOR CLUTCH TEST .....	55-70	HEATER CONTROL ASSEMBLY DISASSEMBLY AND ASSEMBLY .....	55-78

Continued on next page

## WARNINGS REGARDING SERVICING OF SUPPLEMENTAL RESTRAINT SYSTEM (SRS) EQUIPPED VEHICLES

**⚠ WARNING**

- *Improper service or maintenance of any component of the SRS, or any SRS-related component, can lead to personal injury or death to service personnel (from inadvertent firing of the air bag) or to the driver and passenger (from rendering the SRS inoperative).*
- *Service or maintenance of any SRS component or SRS-related component must be performed only at an authorized MITSUBISHI dealer.*
- *MITSUBISHI dealer personnel must thoroughly review this manual, and especially its GROUP 52B - Supplemental Restraint System (SRS) before beginning any service or maintenance of any component of the SRS or any SRS-related component.*

## NOTE

The SRS includes the following components: SRS air bag control unit, SRS warning light, front impact sensors, air bag module, clock spring, and interconnecting wiring. Other SRS-related components (that may have to be removed/installed in connection with SRS service or maintenance) are indicated in the table of contents by an asterisk (\*).

**HEATER UNIT, HEATER CORE, BLOWER  
ASSEMBLY AND EVAPORATOR UNIT\***

.....	<b>55-79</b>
REMOVAL AND INSTALLATION .....	55-79
HEATER UNIT DISASSEMBLY AND ASSEMBLY .....	55-80
BLOWER ASSEMBLY DISASSEMBLY AND ASSEMBLY .....	55-81

**BLOWER ASSEMBLY AND RESISTOR**

.....	<b>55-82</b>
REMOVAL AND INSTALLATION .....	55-82
INSPECTION .....	55-83

**EVAPORATOR ASSEMBLY .....**

REMOVAL AND INSTALLATION .....	55-85
INSPECTION .....	55-86

**COMPRESSOR ASSEMBLY AND TENSION  
PULLEY .....**

REMOVAL AND INSTALLATION .....	55-87
--------------------------------	-------

INSPECTION .....	55-89
DISASSEMBLY AND ASSEMBLY .....	55-89
INSPECTION .....	55-91

**CONDENSER AND CONDENSER FAN  
MOTOR .....**

REMOVAL AND INSTALLATION .....	55-92
INSPECTION .....	55-93

**REFRIGERANT LINE .....**

REMOVAL AND INSTALLATION .....	55-94
--------------------------------	-------

**VENTILATORS .....**

REMOVAL AND INSTALLATION .....	55-95
--------------------------------	-------

**SPECIFICATIONS .....**

FASTENER TIGHTENING SPECIFICATION .....	55-97
GENERAL SPECIFICATION .....	55-97
SERVICE SPECIFICATIONS .....	55-97
LUBRICANT .....	55-97

## GENERAL DESCRIPTION

M1552000100265

The heater system uses a two-way-flow full-air-mix system that features high performance and low operating noise. It includes an independent face air blowing function. In addition, an air purifier has been included.

### SAFETY PRECAUTIONS

#### **⚠ WARNING**

***Wear safety goggles and gloves when servicing the refrigeration system to prevent severe damage to eyes and hands.***

Because R-134a refrigerant is a hydro fluorocarbon (HFC) which contains hydrogen atoms in place of chlorine atoms, it will not cause damage to the ozone layer.

Ozone filters out harmful radiation from the sun. To assist in protecting the ozone layer, Mitsubishi Motors Corporation recommends an R-134a refrigerant recycling device.

Refrigerant R-134a is transparent and colorless in both the liquid and vapor state. Since it has a boiling point of  $-29.8^{\circ}\text{C}$  ( $-21.64^{\circ}\text{F}$ ) at atmospheric pressure, it will be a vapor at all normal temperatures and pressures. The vapor is heavier than air, non-flammable, and non-explosive. The following precautions must be observed when handling R-134a.

#### **⚠ WARNING**

***Do not heat R-134a above  $40^{\circ}\text{C}$  ( $104.0^{\circ}\text{F}$ ) or it may catch fire and explode.***

R-134a evaporates so rapidly at normal atmospheric pressures and temperatures that it tends to freeze anything it contacts. For this reason, extreme care must be taken to prevent any liquid refrigerant from contacting the skin and especially the eyes. Always wear safety goggles when servicing the refrigeration part of the A/C system. Keep a bottle of sterile mineral oil handy when working on the refrigeration system.

1. Should any liquid refrigerant get into the eyes, use a few drops of mineral oil to wash them out. R-134a is rapidly absorbed by the oil.
2. Next splash the eyes with plenty of cold water.
3. Call your doctor immediately even though irritation has ceased after treatment.

#### **⚠ CAUTION**

**Keep R-134a containers upright when charging the system.**

In most instances, moderate heat is required to bring the pressure of the refrigerant in its container above the pressure of the system when charging or adding refrigerant.

A bucket or large pan of hot water not over  $40^{\circ}\text{C}$  ( $104.0^{\circ}\text{F}$ ) is all the heat required for this purpose. Do not heat the refrigerant container with a blow torch or any other means that would raise temperature and pressure above this temperature. Do not weld or steam clean on or near the system components or refrigerant lines.

#### **⚠ WARNING**

***The leak detector for R-134a should be used to check for refrigerant gas leaks.***

#### **⚠ CAUTION**

**Do not allow liquid refrigerant to touch bright metal or it will be stained.**

When metering R-134a into the refrigeration system keep the supply tank or cans in an upright position. If the refrigerant container is on its side or upside down, liquid refrigerant will enter the system and damage the compressor.

Refrigerant will tarnish bright metal and chrome surfaces, and in combination with moisture can severely corrode all metal surfaces.

## OPERATION

### CONDENSER FAN AND RADIATOR FAN CONTROL

For the operation of each fan, refer to GROUP 14, Diagnosis - Symptom Chart [P.14-4](#).

### COMPRESSOR CONTROL

#### **When operating the air conditioning switch**

- The air thermo sensor, which senses the temperature of the air flowing out of the evaporator, deactivates the compressor at  $3.2^{\circ}\text{C}$  ( $37.7^{\circ}\text{F}$ ) or below.
- The dual pressure switch turns OFF when the refrigerant pressure becomes excessively high or low, thus protecting the compressor circuit. (See Table below.)
- When the air thermo sensor is activated, the dual pressure switch is ON, and the ignition switch, blower switch, and air conditioning switch are ON, the A/C compressor relay is energized.

**When operating the air outlet changeover control knob**

- When the air outlet changeover control knob is moved to DEFROSTER or DEFROSTER/FOOT position, the defroster switch, which is connected in series to the air conditioning switch, is turned on. The other compressor control than the above is the same as that when operating the air conditioning switch.

**A/c Compressor Relay ON Conditions**

Ignition switch (IG2)	ON	<i>NOTE: A/C compressor relay is de-energized when any one switch, sensor or control unit shown on the left turns off.</i>	
Blower switch	ON		
Air conditioning switch or defroster switch	ON		
Air thermo sensor	*	<i>NOTE: The * marked device measures the temperature of the outlet air, and according to the control characteristics of the magnetic clutch for the compressor, the automatic compressor controller outputs the "HI" signal (12V). When air of 3.2°C (37.7°F) or less blows out of the evaporator, the compressor magnetic clutch will be turned off.</i>	
Dual pressure switch	Low-pressure side 221 kPa (32.1 psi) or higher		ON
	High-pressure side 2,354 kPa (341.4 psi) or below		ON
A/C compressor relay driving transistor (within engine control module)	ON		

**SERVICE PRECAUTIONS**

**CAUTION LABELS**

M1552017400053

The refrigerant gas warning label must be adhered in the location shown in the figure on the left. Follow the instructions on the label when servicing.

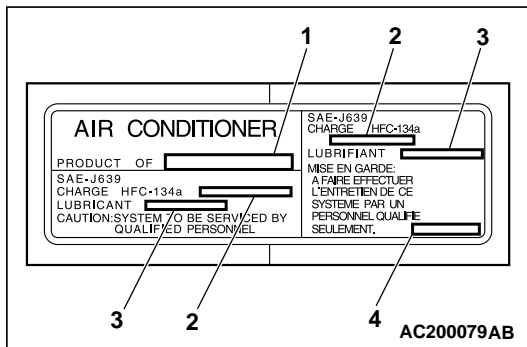
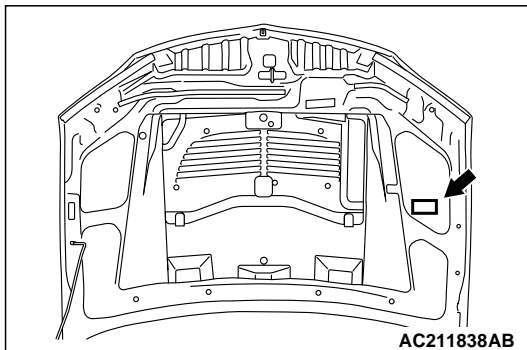

No.	Contents
1	Name of air conditioner manufacturer
2	Amount of refrigerant
3	Name of compressor oil
4	Parts number

## MANUAL A/C DIAGNOSIS

### INTRODUCTION TO HEATER, AIR CONDITIONING AND VENTILATION DIAGNOSIS

M1552012200292

Air is drawn into the heater assembly from either the outside, or from the inside of the passenger cabin if DEFROST, maximum cooling or RECIRCULATION are selected. The air is then forced through the evaporator where heat is removed, cooling and de-humidifying the air. Depending on the temperature selected, a portion of this air is then forced through the heater core to achieve the selected discharge temperature.

If the system does not cool properly, look for a problem with the refrigerant, blower or air distribution systems. If the system does not heat properly, look for a problem with the coolant, blower or air distribution systems. In either case all system fuses, circuit breaker and relays should be checked.

### HEATER, AIR CONDITIONING AND VENTILATION DIAGNOSTIC TROUBLESHOOTING STRATEGY

M1552009600319

Use these steps to plan your diagnostic strategy. If you follow them carefully, you will be sure that you have exhausted most of the possible ways to find a heater, air conditioning and ventilation fault.

1. Gather information from the customer.

2. Verify that the condition described by the customer exists.
3. Find the malfunction by following the Symptom Chart.
4. Verify malfunction is eliminated.

### SYMPTOM CHART

M1552009900406

SYMPTOM	INSPECTION PROCEDURE	REFERENCE PAGE
When the ignition switch is "ON" the A/C does not operate.	1	P.55-6
When the air outlet changeover control knob is moved to defroster or defroster/foot position, the A/C or the inside/outside air changeover damper motor does not operate.	2	P.55-6
Inside/outside air selection is not possible.	3	P.55-7
When the A/C is operating, temperature inside the passenger compartment does not decrease (cool air is not emitted).	4	P.55-15
Blower fan and motor does not turn.	5	P.55-36
Blower air volume cannot be changed.	6	P.55-48
Defroster function does not operate.	7	P.55-54
Defroster timer function does not operate.	8	P.55-64
Malfunction of the A/C-ECU power supply system.	9	P.55-65
A/C condenser fan is inoperative.	-	Refer to GROUP 13A, symptom chart P.13A-27

## SYMPTOM PROCEDURES

**INSPECTION PROCEDURE 1: When the Ignition Switch is "ON" the A/C does not operate.****TECHNICAL DESCRIPTION (COMMENT)**

The blower system or the compressor system may be defective if there is no cool air coming from the spit hole.

**TROUBLESHOOTING HINTS**

- Malfunction of blower motor
- Malfunction of A/C compressor

**DIAGNOSIS**

**Check that the blower motor operation when the blower switch is moved to the "HI" position.**

- (1) Turn the ignition switch to the "ON" position.
- (2) Turn the blower switch to the "HI" position.

**Q: Does the blower motor operate when the blower switch is moved to the "HI" position?**

**YES :** Refer to Inspection procedure 4 "When the A/C is operating, Temperature inside the Passenger compartment does not decrease (cool air not emitted) [P.55-15.](#)"

**NO :** Refer to Inspection procedure 5 "Blower fan and motor does not turn [P.55-36.](#)"

**INSPECTION PROCEDURE 2: When the Air Outlet Changeover Control Knob is Moved to Defroster or Defroster/Foot Position, the A/C or the Inside/outside Air Changeover Damper Motor does not operate.****TECHNICAL DESCRIPTION (COMMENT)**

If the inside/outside air changeover damper motor does not operate normally, the inside/outside air changeover damper motor system may be defective.

**TROUBLESHOOTING HINTS**

- Malformation of the A/C-ECU
- Malformation of the inside/outside air changeover damper motor

**DIAGNOSIS****Required Special Tools:**

- MB991223: Test Harness Set

**Check operations of the outside/inside air selection damper control motor.**

- (1) Turn the ignition switch to the "ON" position.
- (2) Outside/Inside Air Selection Damper Motor Switch: This is used to switch from the inside air to outside air or vice version.
- (3) Check to see that the outside/inside air selection damper motor operates normally.

**Q: Does outside/inside air selection damper control motor work normally?**

**YES :** Replace the A/C-ECU.

**NO :** Refer to Inspection procedure 3 "Inside / Outside Air changeover is not possible [P.55-7.](#)"

INSPECTION PROCEDURE 3: Inside/Outside Air Selection is not possible.

Inside/Outside Air Changeover Damper Motor Circuit

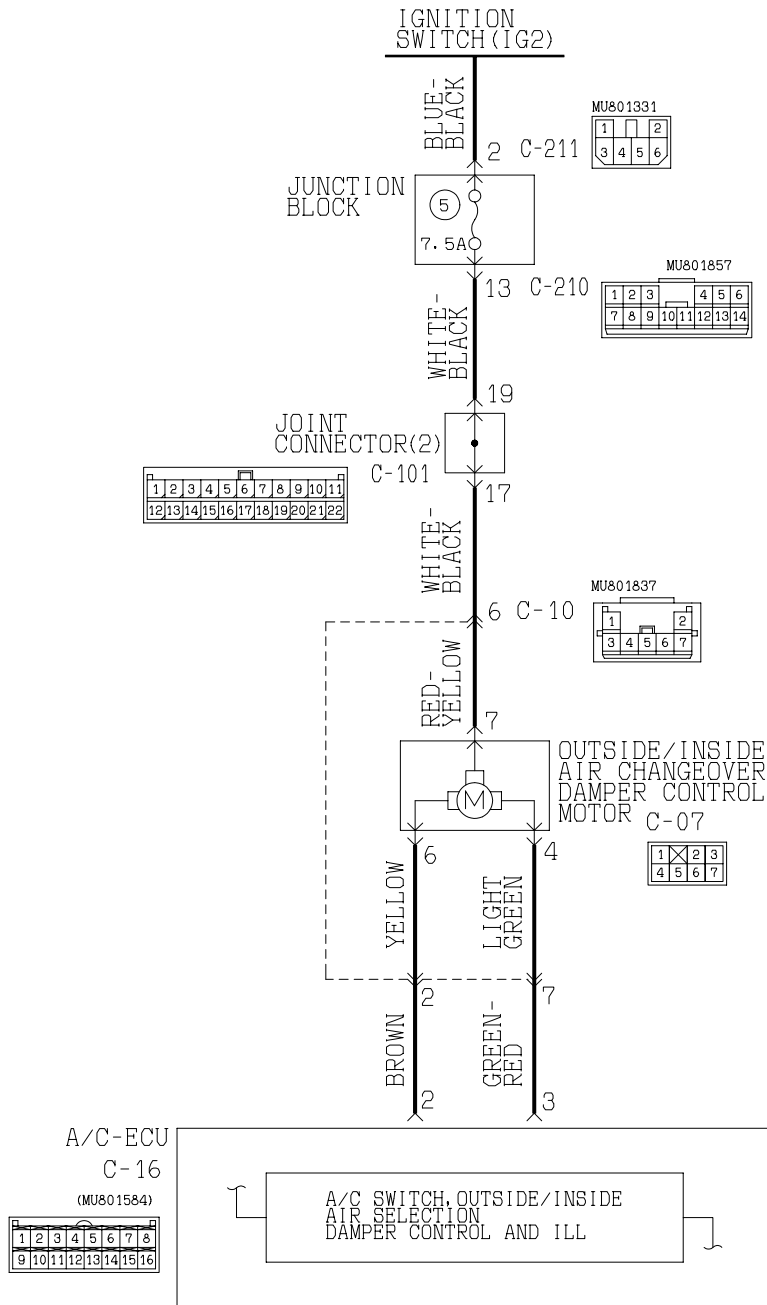

W3J03M05AA

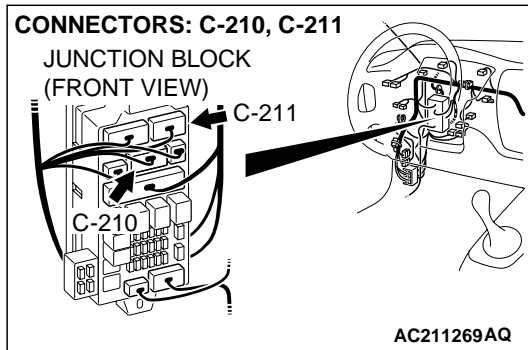
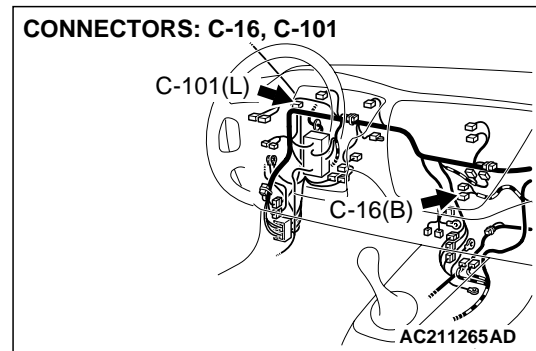
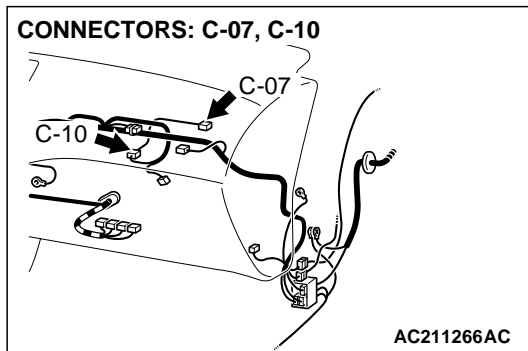

### CIRCUIT OPERATION

The inside/outside air selection damper motor is energized through the ignition switch (IG2). The motor is controlled by the A/C-ECU.

### TECHNICAL DESCRIPTION

If the inside/outside air selection damper motor does not operate normally, the inside/outside air selection damper motor system may be defective.

### TROUBLESHOOTING HINTS

- Malformation of the inside/outside air selection damper motor
- Malformation of the A/C-ECU
- The wiring harness or connectors may have loose, corroded, or damaged terminals, or terminals pushed back in the connector

### DIAGNOSIS

#### Required Special Tools:

- MB991223: Test Harness Set

#### STEP 1. Check the defogger and A/C operations.

#### Q: Do the defogger and A/C work normally?

**YES** : Go to Step 2.

**NO** : Refer to Inspection procedure 9 "Malfunction of the A/C-ECU Power Supply system" P.55-65."



**STEP 2. Check the outside/inside air selection damper control motor**

**⚠ CAUTION**

**Cut off the battery voltage when the damper is in the inside or outside air position.**

Check the outside/inside air selection damper control motor by the following procedures.

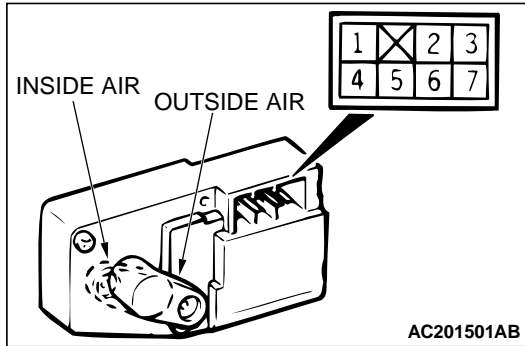

LEVER POSITION	BATTERY CONNECTION	LEVER OPERATION
At the inside position	<ul style="list-style-type: none"> <li>• Connect terminal 7 to the positive battery terminal</li> <li>• Connect terminal 6 to the negative battery terminal</li> </ul>	The lever moves from the inside position to the outside position
At the outside position	<ul style="list-style-type: none"> <li>• Connect terminal 7 to the positive battery terminal</li> <li>• Connect terminal 4 to the negative battery terminal</li> </ul>	The lever moves from the outside position to the inside position

**Q: Does outside/inside air selection damper control motor work normally?**

**YES :** Go to Step 3.

**NO :** Replace the outside/inside air selection damper control motor. Check that the outside/inside air selection damper control motor works normally.

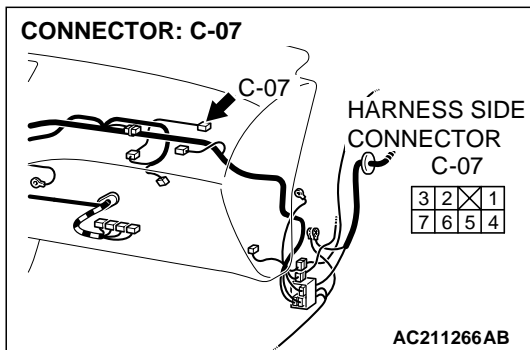
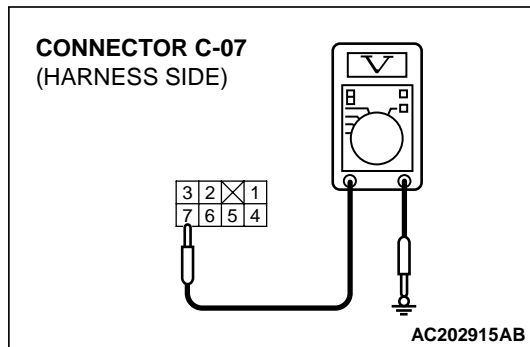
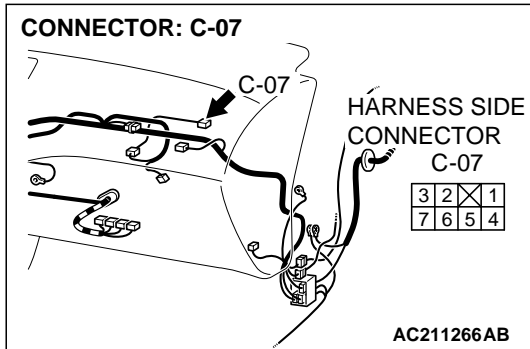

**STEP 3. Measure the voltage at outside/inside air selection damper control motor connector C-07.**

- (1) Disconnect outside/inside air selection damper control motor connector C-07, and measure the voltage at the harness side.
- (2) Turn the ignition switch to the "ON" position.

- (3) Measure the voltage between terminal 7 and ground.
  - The measured value should be approximately 12 volts (battery positive voltage).

**Q: Does the measured voltage correspond with this range?**

**YES :** Go to Step 6.

**NO :** Go to Step 4.

**STEP 4. Check outside/inside air selection damper control motor connector C-07 for loose, corroded or damaged terminals, or terminals pushed back in the connector.**

**Q: Is outside/inside air selection damper control motor connector C-07 in good condition?**

**YES :** Go to Step 5.

**NO :** Repair or replace the connector. Refer to GROUP 00E, Harness Connector Inspection P.00E-2. Check that the outside/inside air selection damper control motor works normally.

**STEP 5. Check the wiring harness between outside/inside air selection damper control motor connector C-07 (terminal 7) and the ignition switch (IG2).**

**CONNECTORS: C-07, C-10**

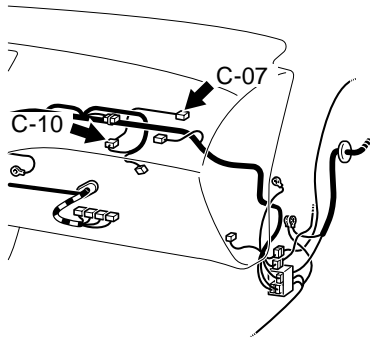

HARNESS SIDE CONNECTOR  
C-07



HARNESS SIDE CONNECTOR  
C-10

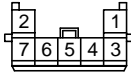

AC211308AB

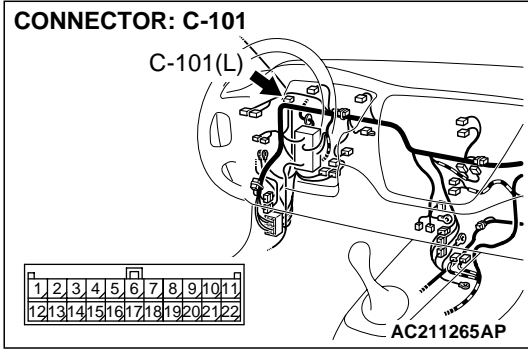

*NOTE: Also check intermediate connector C-10, joint connector (2) C-101, junction block connectors C-210 and C-211 for loose, corroded, or damaged terminals, or terminals pushed back in the connector. If intermediate connector C-10, joint connector (2) C-101, junction block connectors C-210 or C-211 is damaged, repair or replace the connector as described in GROUP 00E, Harness Connector Inspection P.00E-2.*

**Q: Is the wiring harness between outside/inside air selection damper control motor connector C-07 (terminal 7) and the ignition switch (IG2) in good condition?**

**YES :** Check that the outside/inside air selection damper control motor works normally.

**NO :** Repair the wiring harness. Check that the outside/inside air selection damper control motor works normally.

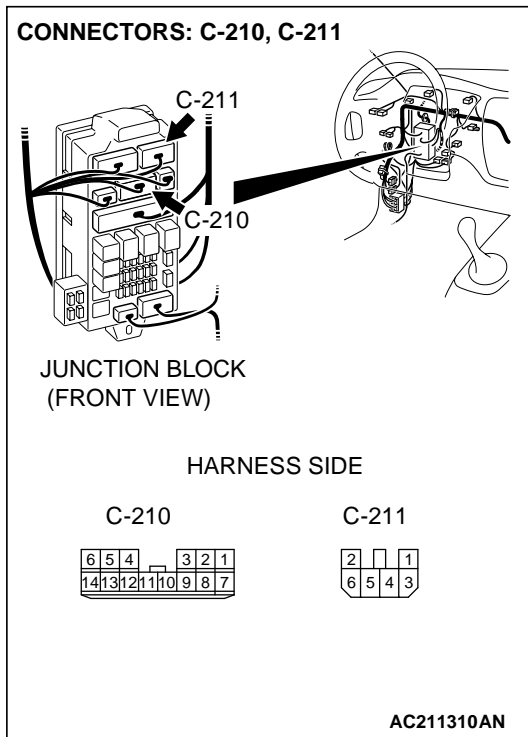

**STEP 6.** Check outside/inside air selection damper control motor connector C-07 and A/C-ECU connector C-16 for loose, corroded or damaged terminals, or terminals pushed back in the connector.

**Q:** Is outside/inside air selection damper control motor connector C-07 and A/C-ECU connector C-16 in good condition?

**YES :** Go to Step 7.

**NO :** Repair or replace the connector. Refer to GROUP 00E, Harness Connector Inspection [P.00E-2](#). Check that the outside/inside air selection damper control motor works normally.

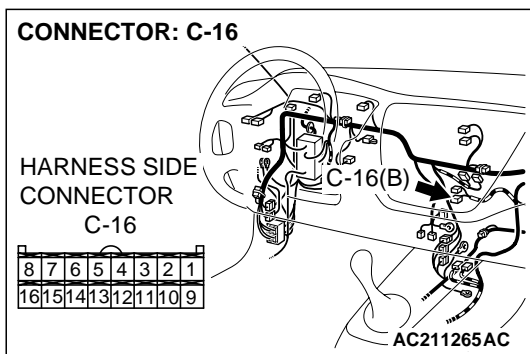
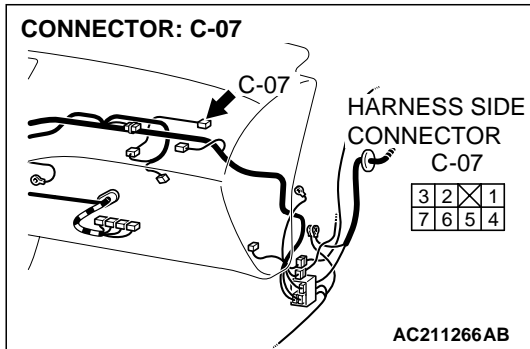

**STEP 7. Check the wiring harness between outside/inside air selection damper control motor connector C-07 (terminals 6 and 4) and A/C-ECU connector C-16 (terminals 2 and 3).**

*NOTE: Also check intermediate connector C-10 for loose, corroded, or damaged terminals, or terminals pushed back in the connector. If intermediate connectors C-10 is damaged, repair or replace the connector as described in GROUP 00E, Harness Connector Inspection P.00E-2.*

**Q: Is the wiring harness between outside/inside air selection damper control motor connector C-07 (terminal 6 and 4) and A/C-ECU connector C-16 (terminal 2 and 3) in good condition?**

**YES :** Replace the A/C-ECU, and check that the outside/inside air selection damper control motor works normally.

**NO :** Repair the wiring harness. Check that the outside/inside air selection damper control motor works normally.

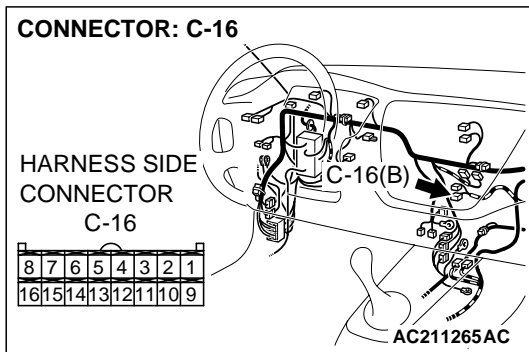
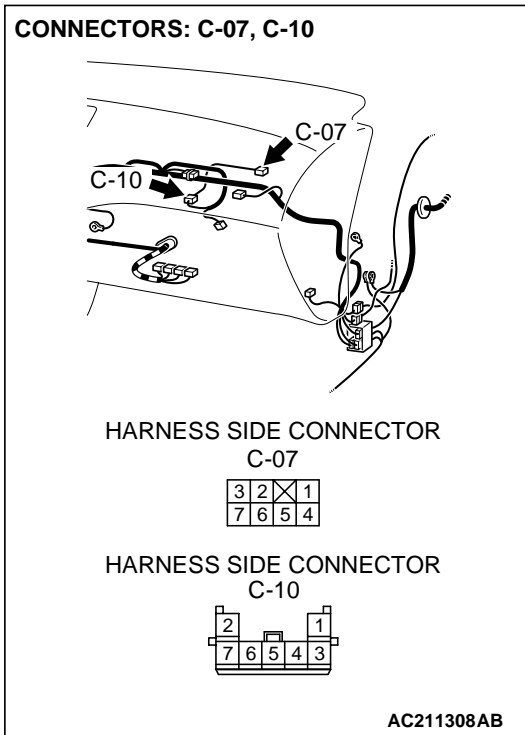

**INSPECTION PROCEDURE 4: When the A/C is Operating, Temperature Inside the Passenger Compartment does not Decrease (Cool Air is not Emitted).**

A/C Compressor and Air Thermo Sensor Circuit

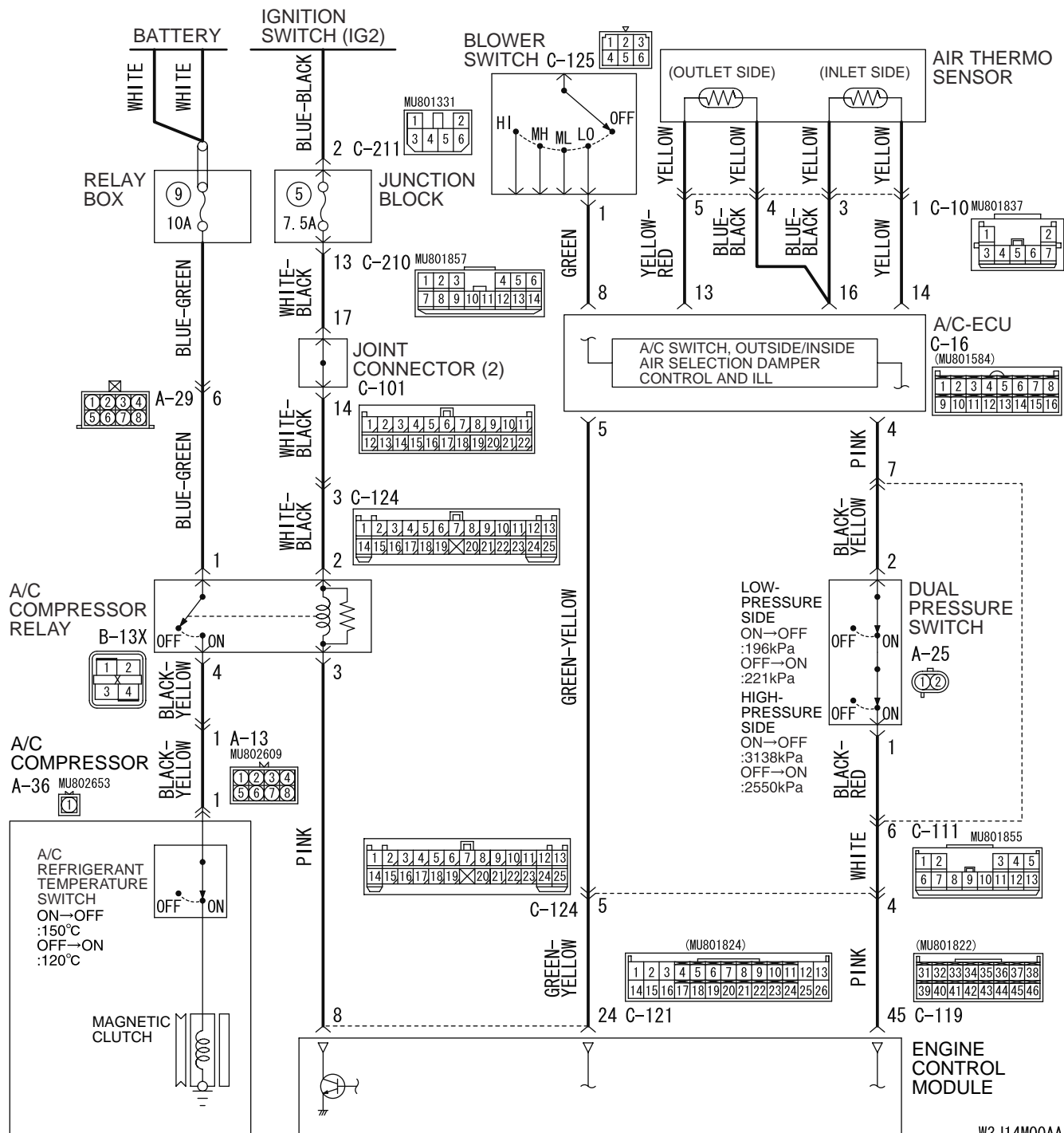

W3J14M00AA

CONNECTORS: A-13, A-29

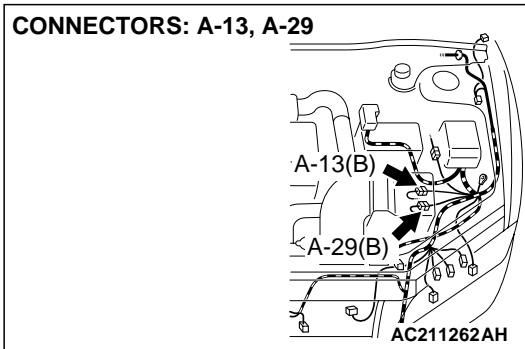
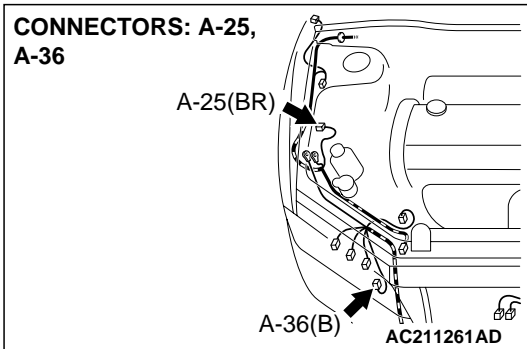
CONNECTORS: A-25,  
A-36

CONNECTOR: B-13X

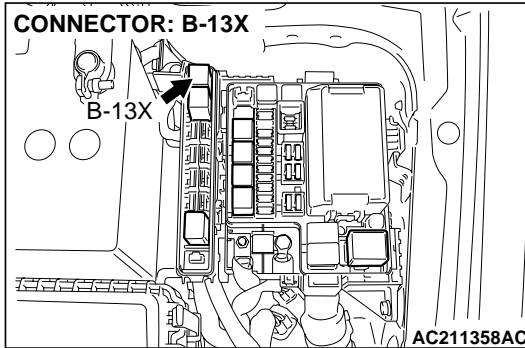

CONNECTORS: C-10, C-111, C-119, C-121

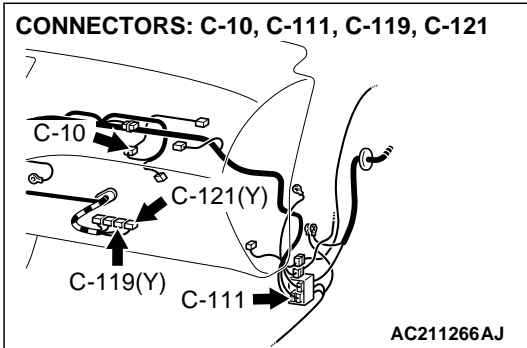

CONNECTORS: C-16, C-101, C-124, C-125

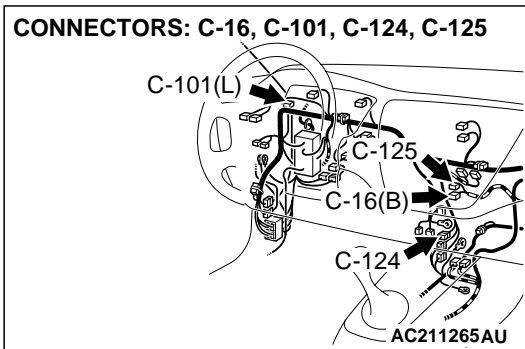

CONNECTORS: C-210, C-211

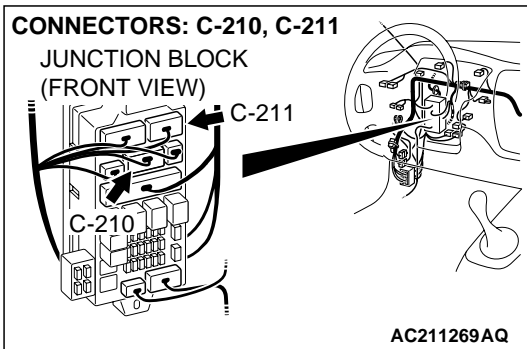
**TECHNICAL DESCRIPTION (COMMENT)**

If cool air is not distributed when the A/C switch is on, the air thermo sensor or the A/C compressor relay system may be defective.

**TROUBLESHOOTING HINTS**

- Malformation of the air thermo sensor
- Malformation of the dual pressure switch
- Malformation of the A/C compressor relay
- Malformation of the A/C refrigerant temperature switch
- Malformation of the magnetic clutch
- Malformation of the A/C-ECU
- Malformation of the ECM
- The wiring harness or connectors may have loose, corroded, or damaged terminals, or terminals pushed back in the connector



**DIAGNOSIS**

**Required Special Tools:**

- MB991223: Test Harness Set

**STEP 1. Check the defogger and outside/inside air selection damper control motor operation.**

**Q: Do the defogger and outside/inside air selection damper control motor work normally?**

**YES :** Go to Step 2.

**NO :** Refer to Inspection procedure 9 "Malfunction does not operate P.55-65."

**STEP 2. Check the blower motor operation.**

**Q: Does the blower motor work normally?**

**YES :** Go to Step 3.

**NO :** Refer to Inspection procedure 5 "Blower Fan and motor does not turn P.55-36."

**STEP 3. Check the A/C compressor.**

Check the A/C compressor for compressor oil leaks.

**Q: Is the check result satisfactory?**

**YES :** Go to Step 4.

**NO :** Replace the A/C compressor or the expansion valve.

**STEP 4. Check the A/C compressor relay continuity.**

Follow the table below to check the A/C compressor relay for continuity.

BATTERY VOLTAGE	TESTER CONNECTION	SPECIFIED CONDITION
Not applied	1 – 4	Open circuit
<ul style="list-style-type: none"> <li>• Connect terminal 2 to the positive battery terminal</li> <li>• Connect terminal 3 to the negative battery terminal</li> </ul>	1 – 4	Less than 2 ohms

**Q: Is the A/C compressor relay in good condition?**

**YES :** Go to Step 5.

**NO :** Replace the A/C compressor relay. Check that the air conditioning works normally.

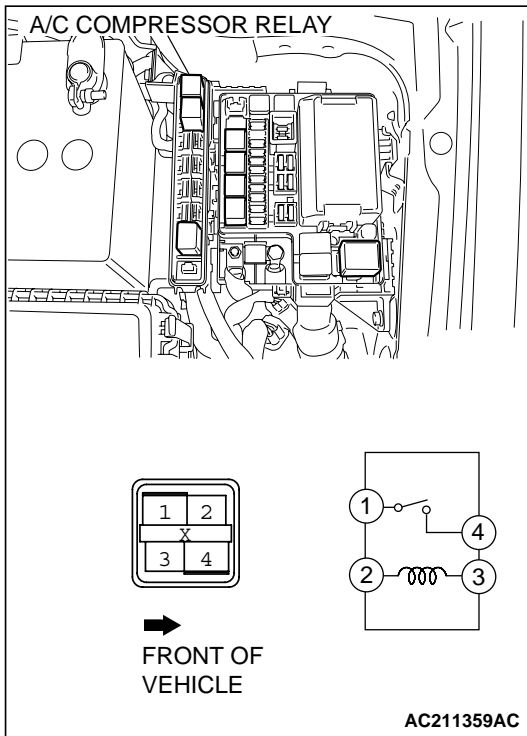

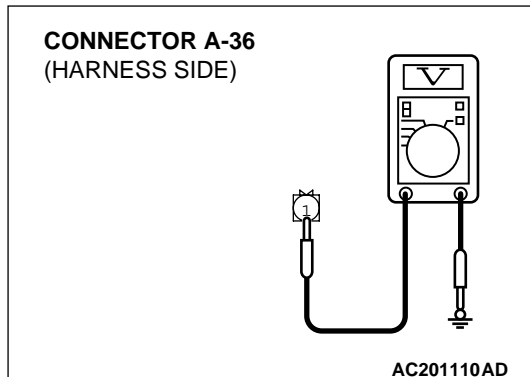
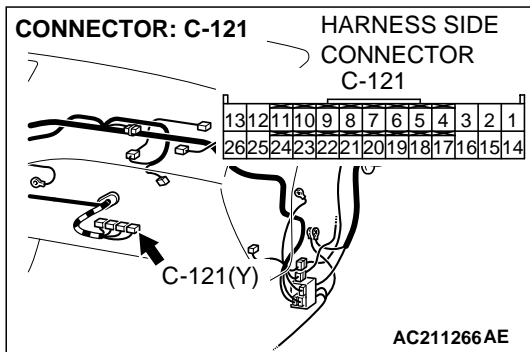
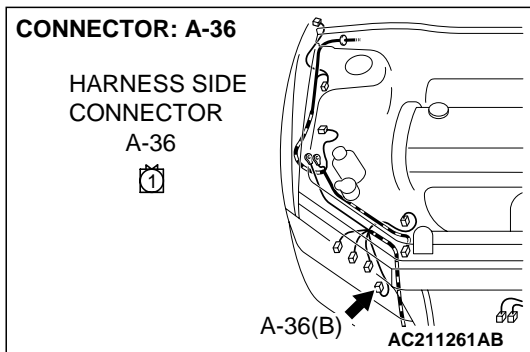

**STEP 5. Measure the voltage at A/C compressor connector A-36.**

(1) Disconnect A/C compressor connector A-36 and measure the voltage at the harness side.

(2) Disconnect engine control module connector C-121, and ground terminal 8.

(3) Turn the ignition switch to the "ON" position.

(4) Measure the voltage between terminal 1 and ground.

- The measured value should be approximately 12 volts (battery positive voltage).

**Q: Does the measured voltage correspond with this range?**

**YES :** Go to Step 16.

**NO :** Go to Step 6.

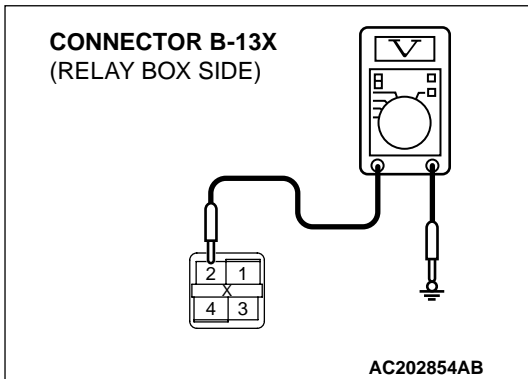
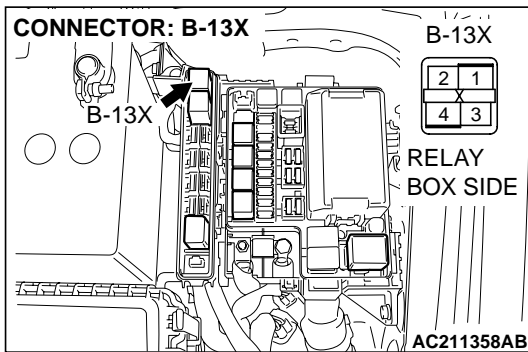

**STEP 6. Measure the voltage at A/C compressor relay connector B-13X.**

- (1) Disconnect A/C compressor connector B-13X and measure the voltage at the relay box side.
- (2) Turn the ignition switch to the "ON" position.

- (3) Measure the voltage between terminal 2 and ground.
  - The measured value should be approximately 12 volts (battery positive voltage).

**Q: Does the measured voltage correspond with this range?**

**YES :** Go to Step 9.

**NO :** Go to Step 7.

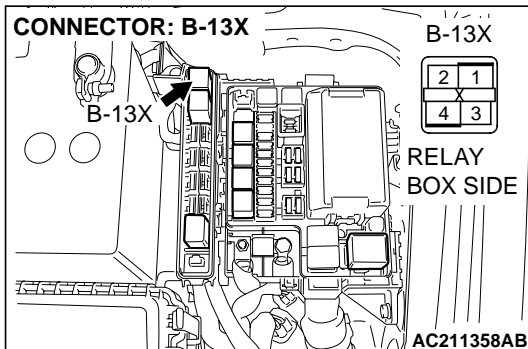

**STEP 7. Check A/C compressor relay connector B-13X for loose, corroded or damaged terminals, or terminals pushed back in the connector.**

**Q: Is A/C compressor relay connector B-13X in good condition?**

**YES :** Go to Step 8.

**NO :** Repair or replace the connector. Refer to GROUP 00E, Harness Connector Inspection [P.00E-2](#). Check that the air conditioning works normally.

**STEP 8.** Check the wiring harness between A/C compressor relay connector B-13X (terminal 2) and the ignition switch (IG2).

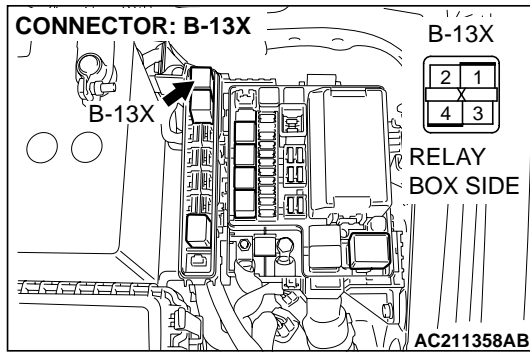

CONNECTORS: C-101, C-124

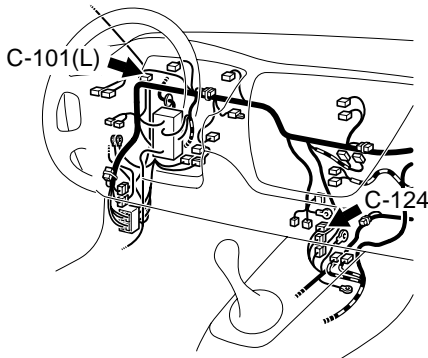

HARNESS SIDE CONNECTOR

C-101

11	10	9	8	7	6	5	4	3	2	1
22	21	20	19	18	17	16	15	14	13	12

C-124

13	12	11	10	9	8	7	6	5	4	3	2	1
25	24	23	22	21	20	19	18	17	16	15	14	

AC211307AB

*NOTE: Also check intermediate connector C-124, joint connector (2) C-101, junction block connectors C-210 and C-211. If intermediate connector C-124, joint connector (2) C-101, or junction block connectors C-210 or C-211 is loose, corroded or damaged terminals, or terminals pushed back in the connector., repair or replace the connector as described in GROUP 00E, Harness Connector Inspection P.00E-2.*

**Q: Is the wiring harness between A/C compressor relay connector B-13X (terminal 2) and the ignition switch (IG2) in good condition?**

**YES :** Check that the air conditioning works normally.

**NO :** Repair the wiring harness. Check that the air conditioning works normally.

CONNECTORS: C-210, C-211

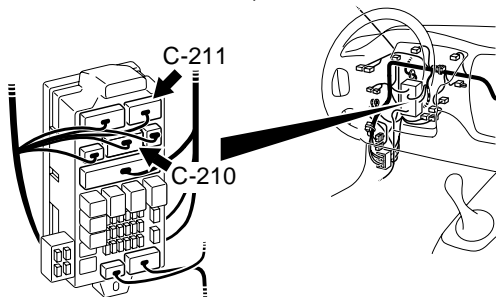

JUNCTION BLOCK  
(FRONT VIEW)

HARNESS SIDE

C-210

6	5	4	3	2	1		
14	13	12	11	10	9	8	7

C-211

2	1		
6	5	4	3

AC211310AN

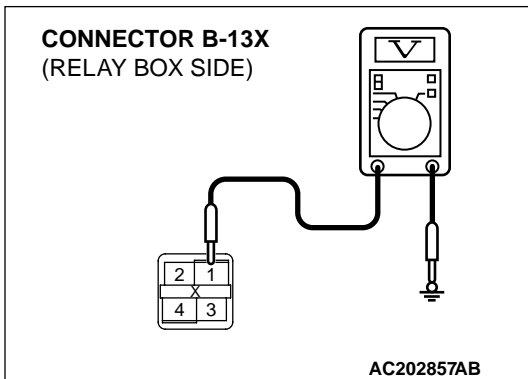
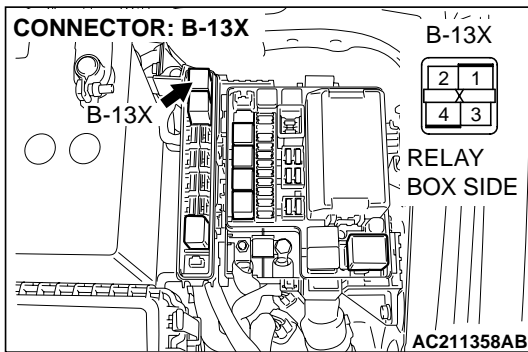

**STEP 9. Measure the voltage at A/C compressor relay connector B-13X.**

(1) Disconnect A/C compressor connector B-13X and measure the voltage at the relay box side.

(2) Measure the voltage between terminal 1 and ground.

- The measured value should be approximately 12 volts (battery positive voltage).

**Q: Does the measured voltage correspond with this range?**

**YES :** Go to Step 12.

**NO :** Go to Step 10.

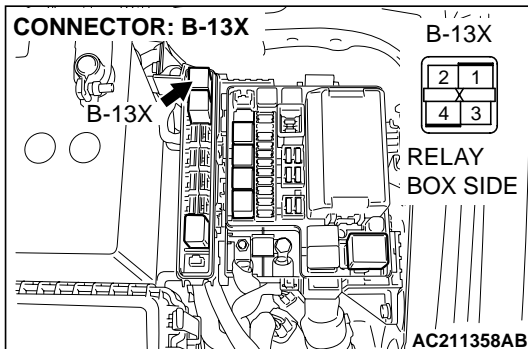

**STEP 10. Check A/C compressor relay connector B-13X for loose, corroded or damaged terminals, or terminals pushed back in the connector.**

**Q: Is A/C compressor relay connector B-13X in good condition?**

**YES :** Go to Step 11.

**NO :** Repair or replace the connector. Refer to GROUP 00E, Harness Connector Inspection [P.00E-2](#). Check that the air conditioning works normally.

**STEP 11. Check the wiring harness between A/C compressor relay connector B-13X (terminal 1) and the battery.**

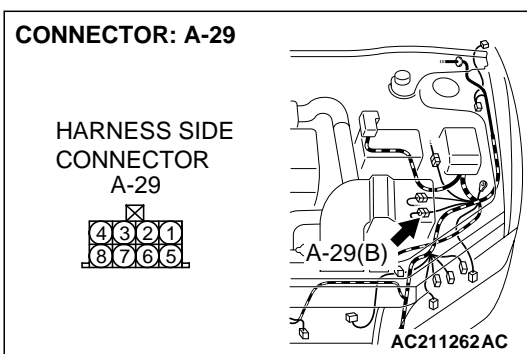
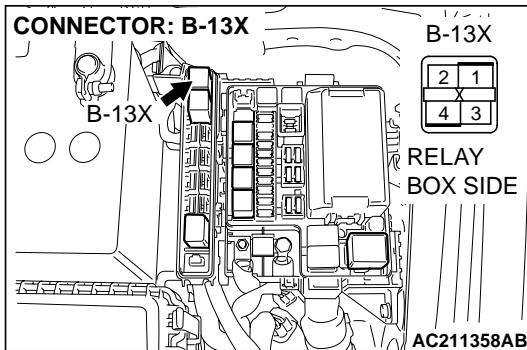

*NOTE: Also check intermediate connector A-29. If intermediate connectors A-29 is loose, corroded or damaged terminals, or terminals pushed back in the connector., repair or replace the connector as described in GROUP 00E, Harness Connector Inspection P.00E-2.*

**Q: Is the wiring harness between A/C compressor relay connector B-13X (terminal 1) and the battery in good condition?**

**YES :** Check that the air conditioning works normally.

**NO :** Repair the wiring harness. Check that the air conditioning works normally.

**STEP 12. Check A/C compressor relay connector B-13X and A/C compressor connector A-36 for loose, corroded or damaged terminals, or terminals pushed back in the connector.**

**Q: Is A/C compressor relay connector B-13X and A/C compressor connector A-36 in good condition?**

**YES :** Go to Step 13.

**NO :** Repair or replace the connector. Refer to GROUP 00E, Harness Connector Inspection P.00E-2. Check that the air conditioning works normally.

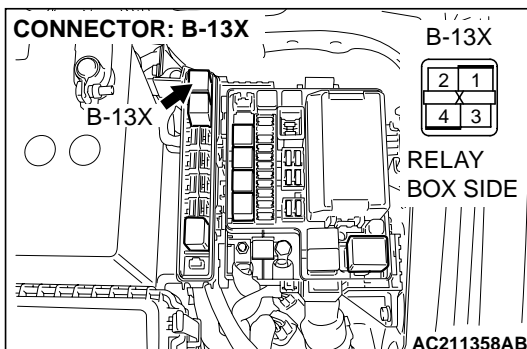
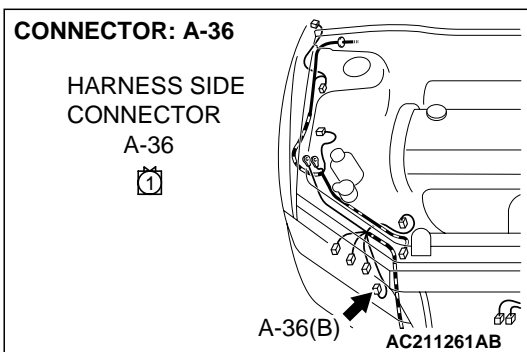

**STEP 13.** Check the wiring harness between A/C compressor relay connector B-13X (terminal 4) and A/C compressor connector A-36 (terminal 1).

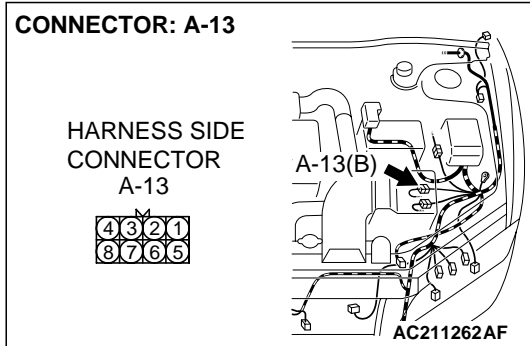
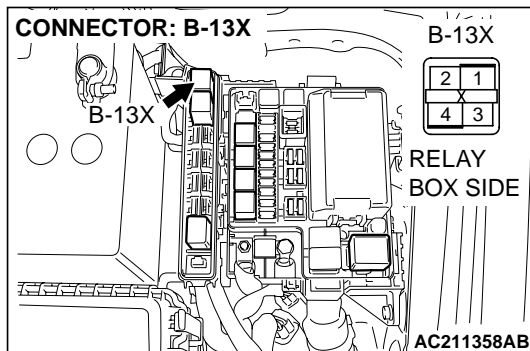
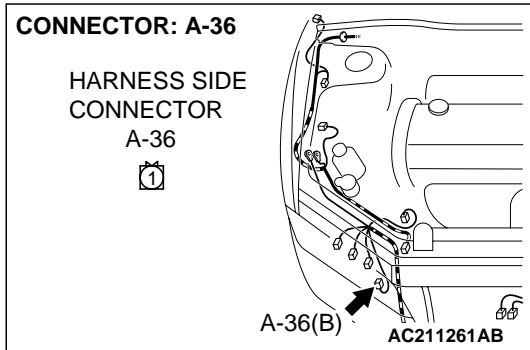

*NOTE: Also check intermediate connector A-13. If intermediate connectors A-13 is loose, corroded or damaged terminals, or terminals pushed back in the connector., repair or replace the connector as described in GROUP 00E, Harness Connector Inspection P.00E-2.*

**Q: Is the wiring harness between A/C compressor relay connector B-13X (terminal 4) and A/C compressor connector A-36 (terminal 1) in good condition?**

**YES :** Go to Step 14.

**NO :** Repair the wiring harness. Check that the air conditioning works normally.



**STEP 14.** Check engine control module connector C-121 and A/C compressor relay connector B-13X for loose, corroded or damaged terminals, or terminals pushed back in the connector.

**Q:** Are engine control module connector C-121 and A/C compressor relay connector B-13X in good condition?

**YES :** Go to Step 15.

**NO :** Repair or replace the connector. Refer to GROUP 00E, Harness Connector Inspection P.00E-2. Check that the air conditioning works normally.

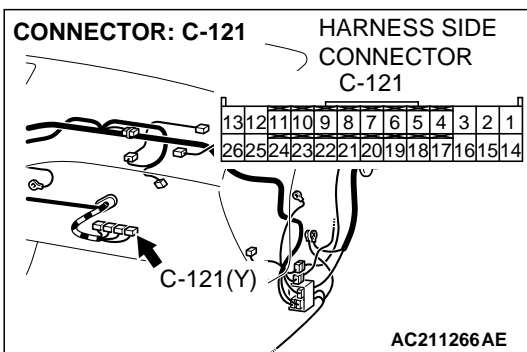
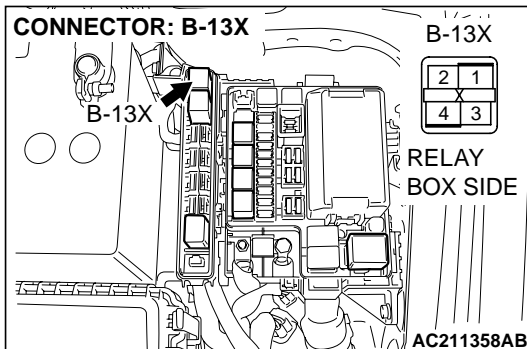

**STEP 15.** Check the wiring harness between engine control module connector C-121 (terminal 8) and A/C compressor relay connector B-13X (terminal 3).

**Q:** Is the wiring harness between engine control module connector C-121 (terminal 8) and A/C compressor relay connector B-13X (terminal 3) in good condition?

**YES :** Check that the air conditioning works normally.

**NO :** Repair the wiring harness. Check that the air conditioning works normally.

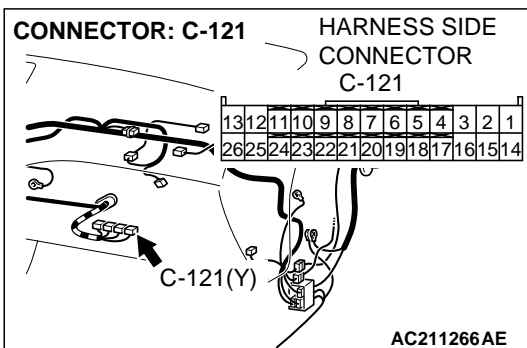
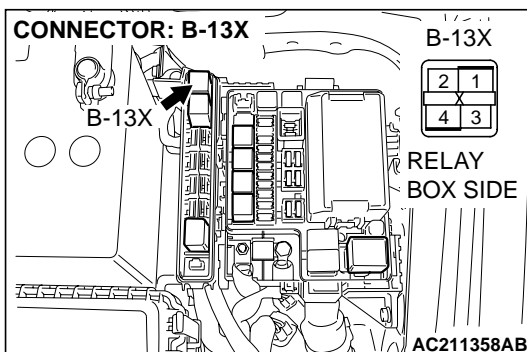

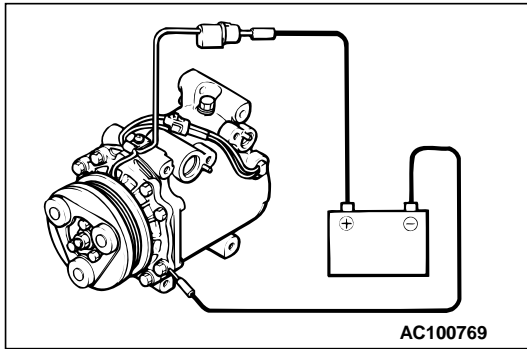
**STEP 16. Check the magnetic clutch operation.**

Connect the positive battery terminal to the compressor magnetic clutch connector terminal and ground the battery (-) terminal to the body of the compressor.

**Q: Can the sound of the magnetic clutch (click) be heard?**

**YES :** Go to Step 17.

**NO :** Replace the compressor magnet clutch. Check that the air conditioning works normally.

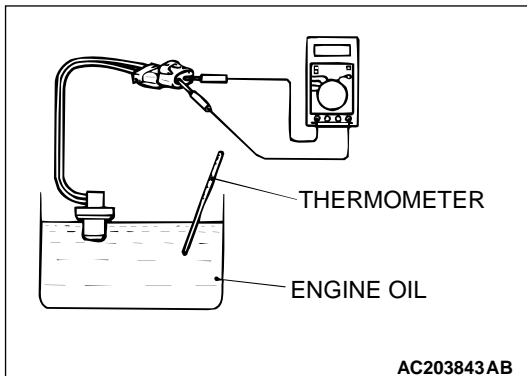
**STEP 17. Check the refrigerant temperature switch.****⚠ CAUTION**

**Do not heat more than necessary.**

(1) Dip the metal part of the refrigerant temperature switch into engine oil and increase the oil temperature using a gas burner or similar.

(2) When the oil temperature reaches the standard value, check that voltage is supplied between the terminals.

**Standard value:**

ITEM	TEMPERATURE
Less than 2 ohms	Slightly below 150°C (302°F)
No continuity	150°C (302°F) or more

*NOTE: When the oil temperature is 150°C (302°F) or more and there is no continuity, the resistance will not be 2Ω or lower until the oil temperature reduces to 120°C (248°F) or less.*

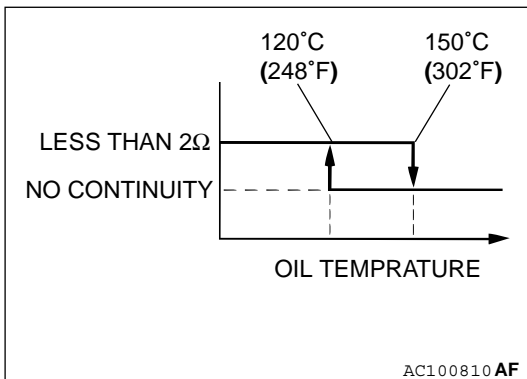

**Q: Is the refrigerant temperature switch operating properly?**

**YES :** Go to Step 18.

**NO :** Replace the refrigerant temperature switch. Check that the air conditioning works normally.

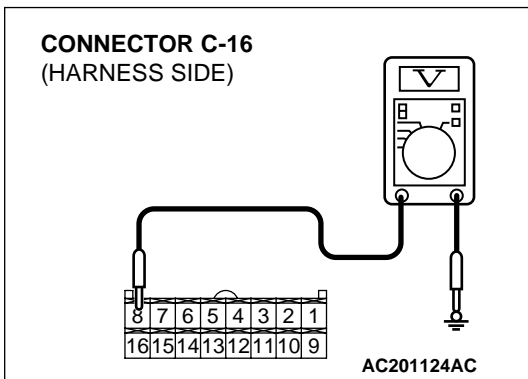
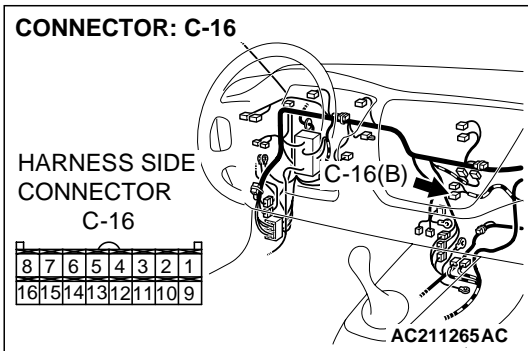

**STEP 18. Measure the voltage at A/C-ECU connector C-16.**

- (1) Disconnect A/C-ECU connector C-16 and measure the voltage at the relay box side.
- (2) Turn the ignition switch to the "ON" position.
- (3) Turn the blower switch to the "ON" position.

- (4) Measure the voltage between terminal 8 and ground.
  - The measured value should be approximately 12 volts (battery positive voltage).

**Q: Does the measured voltage correspond with this range?**

**YES :** Go to Step 21.

**NO :** Go to Step 19.

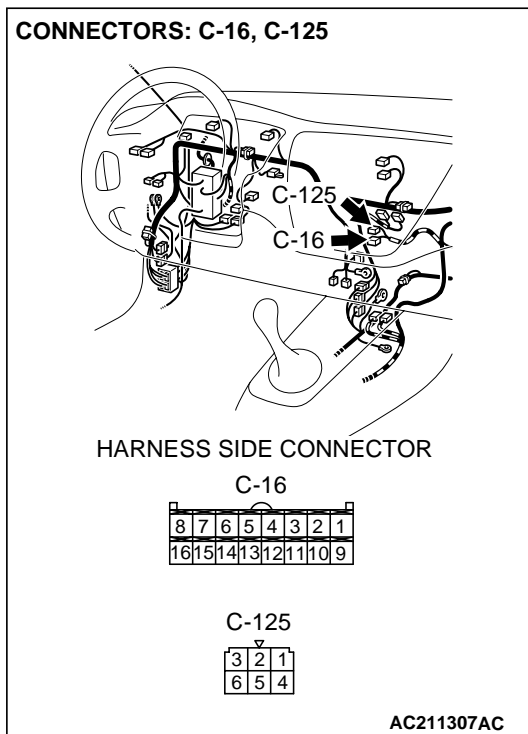

**STEP 19. Check blower switch connector C-125 and A/C-ECU connector C-16 for loose, corroded or damaged terminals, or terminals pushed back in the connector.**

**Q: Is blower switch connector C-125 and A/C-ECU connector C-16 in good condition?**

**YES :** Go to Step 20.

**NO :** Repair or replace the connector. Refer to GROUP 00E, Harness Connector Inspection [P.00E-2](#). Check that the air conditioning works normally.

CONNECTORS: C-16, C-125

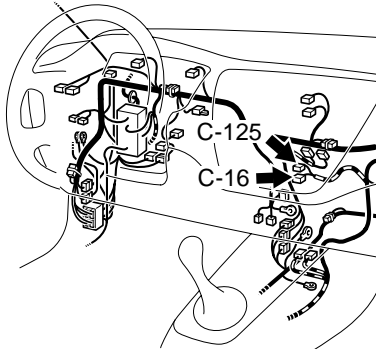

HARNESS SIDE CONNECTOR

C-16

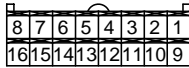

C-125



AC211307AC

**STEP 20. Check the wiring harness between blower switch connector C-125 (terminal 1) and A/C-ECU connector C-16 (terminal 8).**

**Q: Is the wiring harness between blower switch connector C-125 (terminal 1) and A/C-ECU connector C-16 (terminal 8) in good condition?**

**YES :** Check that the air conditioning works normally.

**NO :** Repair the wiring harness. Check that the air conditioning works normally.

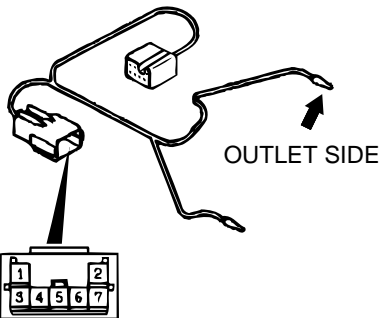

RESISTANCE  
(kΩ)

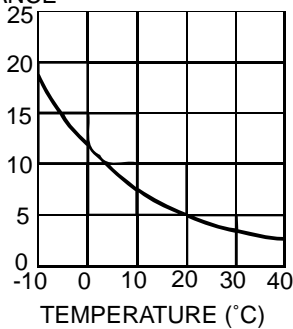

AC100770AC

**STEP 21. Check the air thermo sensor (outlet side)**

- (1) Measure the resistance between air thermo sensor (outlet side) terminal numbers 4 and 5 at two points or more.
- (2) Check that the measured value corresponds with approximately the shown value.

**Q: Is the air thermo sensor (outlet side) in good condition?**

**YES :** Go to Step 22.

**NO :** Replace the air thermo sensor. Check that the air conditioning works normally.

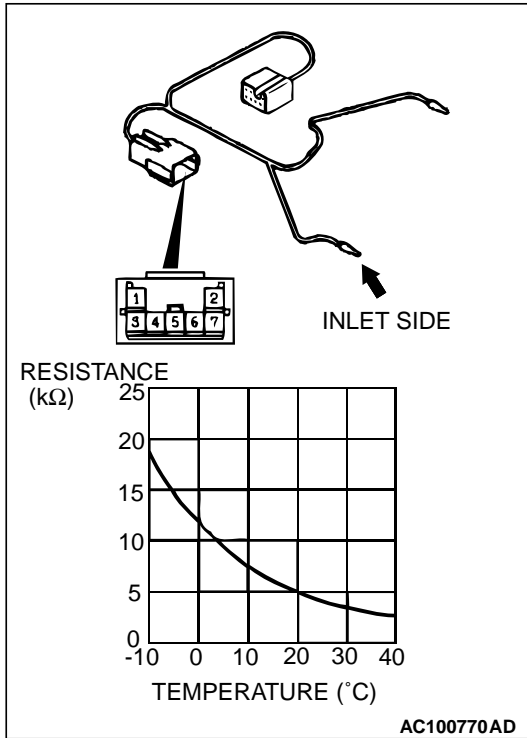

**STEP 22. Check the air thermo sensor (inlet side)**

- (1) Measure the resistance between air thermo sensor (inlet side) terminal numbers 1 and 3 at two points or more.
- (2) Check that the measured value corresponds with approximately the shown value.

**Q: Is the air thermo sensor (inlet side) in good condition?**

**YES :** Go to Step 23.

**NO :** Replace the air thermo sensor. Check that the air conditioning works normally.

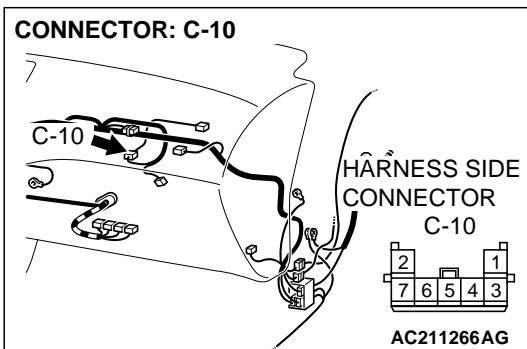

**STEP 23. Check air thermo sensor connector C-10 and A/C-ECU connector C-16 for loose, corroded or damaged terminals, or terminals pushed back in the connector.**

**Q: Are air thermo sensor connector C-10 and A/C-ECU connector C-16 in good condition?**

**YES :** Go to Step 24.

**NO :** Repair or replace the connector. Refer to GROUP 00E, Harness Connector Inspection P.00E-2. Check that the air conditioning works normally.

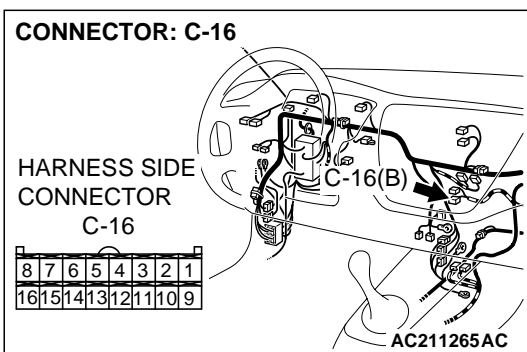

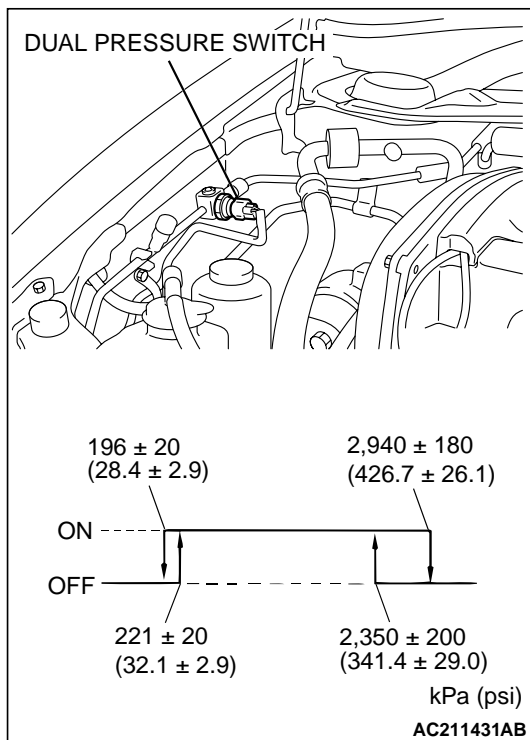
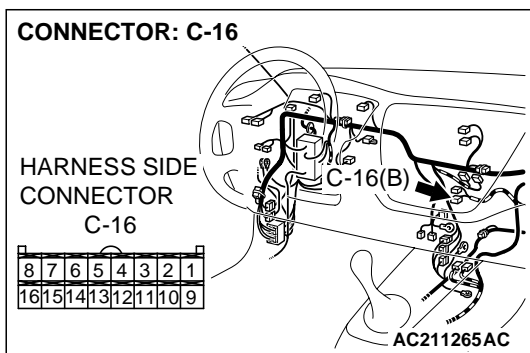
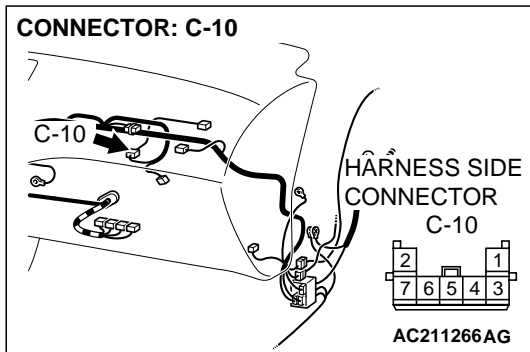

**STEP 24. Check the wiring harness between air thermo sensor connector C-10 (terminals 1, 3, 4 and 5) and A/C-ECU connector C-16 (terminals 14, 16 and 13).**

**Q: Are the wiring harness between air thermo sensor connector C-10 (terminals 1, 3, 4 and 5) and A/C-ECU connector C-16 (terminals 14, 16 and 13) in good condition?**

**YES :** Go to Step 25.

**NO :** Repair the wiring harness. Check that the air conditioning works normally.

**STEP 25. Check the dual pressure switch operation.**

- (1) Remove the dual pressure switch connector and connect the high/low pressure side terminals located on the harness side as shown in the illustration.
- (2) Install a gauge manifold to the high-pressure side service valve of the refrigerant line. Refer to P.55-94.
- (3) When the high/low pressure sides of the dual pressure switch are at operation pressure (ON) the resistance should be less than two ohms between the terminals. If open circuit, replace the switch.

ITEM	SWITCH POSITION	
	OFF to ON	ON to OFF
Low-pressure side kPa (psi)	221 ± 20 (32.1 ± 2.9)	196 ± 20 (28.4 ± 2.9)
High-pressure side kPa (psi)	2,350 ± 200 (341.4 ± 29.0)	2,940 ± 180 (426.7 ± 26.1)

**Q: Is the dual pressure switch operating properly?**

**YES :** Go to Step 26.

**NO :** Replace the dual pressure switch. Check that the air conditioning works normally.

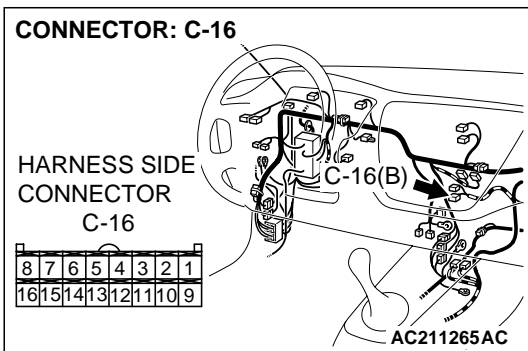
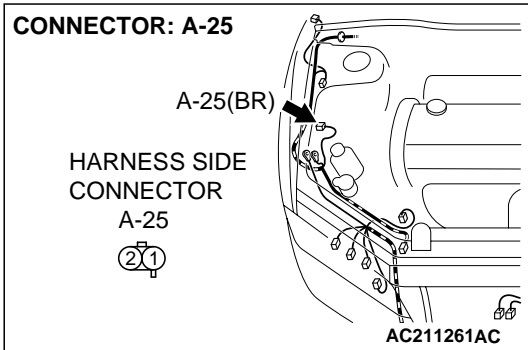

**STEP 26.** Check dual pressure switch connector A-25 and A/C-ECU connector C-16 for loose, corroded or damaged terminals, or terminals pushed back in the connector.

**Q:** Are dual pressure switch connector A-25 and A/C-ECU connector C-16 in good condition?

**YES :** Go to Step 27.

**NO :** Repair or replace the connector. Refer to GROUP 00E, Harness Connector Inspection P.00E-2. Check that the air conditioning works normally.

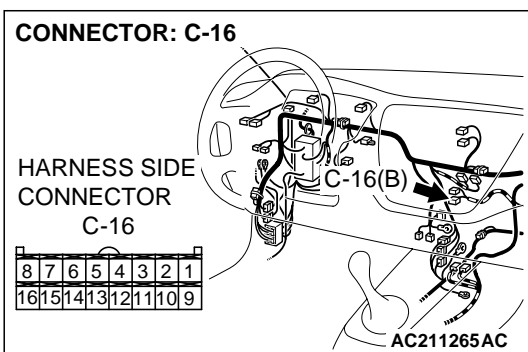
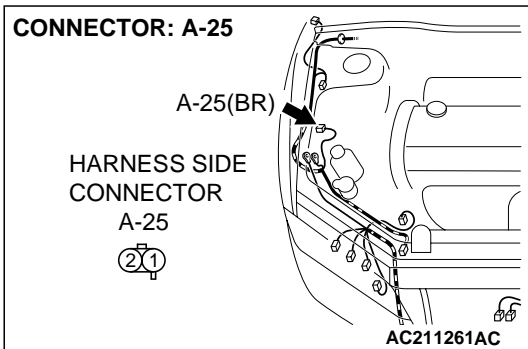

**STEP 27.** Check the wiring harness between dual pressure switch connector A-25 (terminal 2) and A/C-ECU connector C-16 (terminal 4).

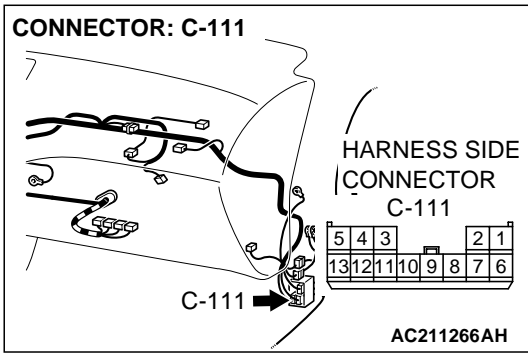

*NOTE: Also check intermediate connector C-111 for loose, corroded, or damaged terminals, or terminals pushed back in the connector. If intermediate connector C-111 is damaged, repair or replace the connector as described in GROUP 00E, Harness Connector Inspection P.00E-2.*

**Q: Is the wiring harness between dual pressure switch connector A-25 (terminal 2) and A/C-ECU connector C-16 (terminal 4) in good condition?**

**YES :** Go to Step 28.

**NO :** Repair the wiring harness. Check that the air conditioning works normally.

**STEP 28. Check dual pressure switch connector A-25 and engine control module connector C-119 for loose, corroded or damaged terminals, or terminals pushed back in the connector.**

**Q: Are dual pressure switch connector A-25 and engine control module connector C-119 in good condition?**

**YES :** Go to Step 29.

**NO :** Repair or replace the connector. Refer to GROUP 00E, Harness Connector Inspection P.00E-2. Check that the air conditioning works normally.

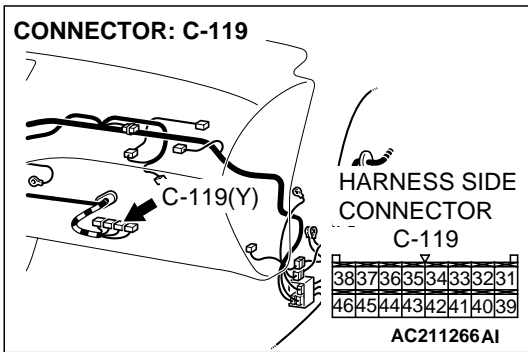
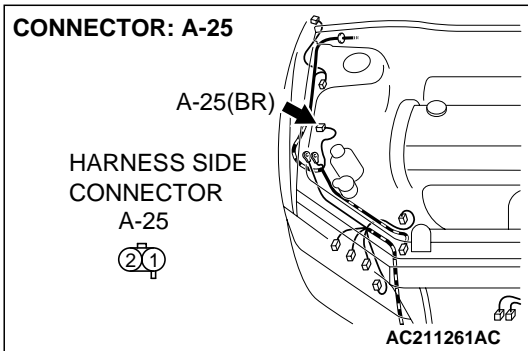



**STEP 29.** Check the wiring harness between dual pressure switch connector A-25 (terminal 1) and engine control module connector C-119 (terminal 45).

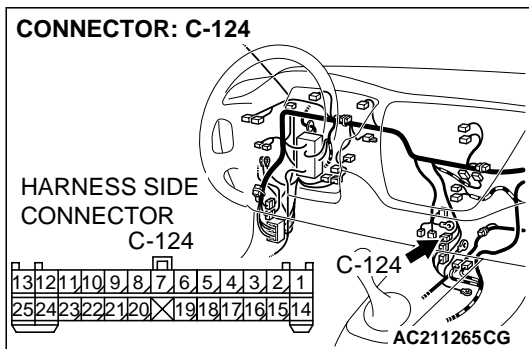
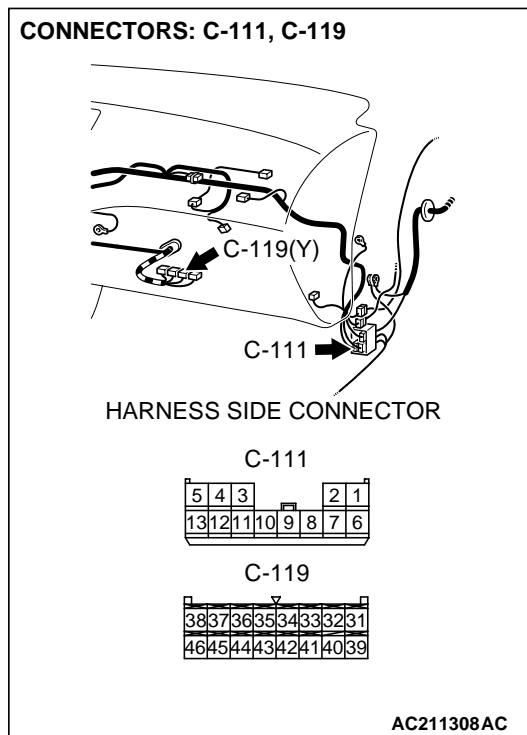
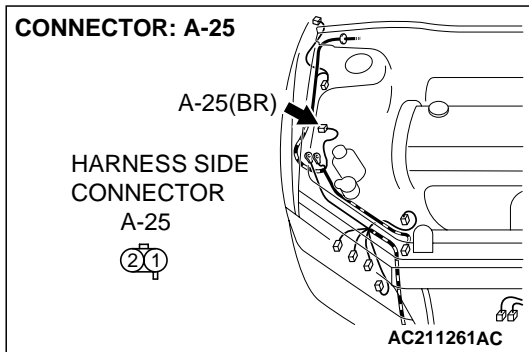

*NOTE:* Also check intermediate connectors C-111 and C-124 for loose, corroded, or damaged terminals, or terminals pushed back in the connector. If intermediate connector C-111 or C-124 is damaged, repair or replace the connector as described in GROUP 00E, Harness Connector Inspection [P.00E-2](#).

**Q:** Is the wiring harness between dual pressure switch connector A-25 (terminal 2) and engine control module connector C-119 (terminal 45) in good condition?

**YES :** Go to Step 30.

**NO :** Repair the wiring harness. Check that the air conditioning works normally.

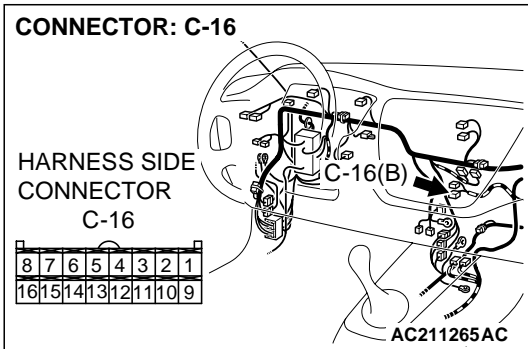

**STEP 30.** Check A/C-ECU connector C-16 and engine control module connector C-121 for loose, corroded or damaged terminals, or terminals pushed back in the connector.

**Q:** Are A/C-ECU connector C-16, engine control module connector C-121 in good condition?

**YES :** Go to Step 31.

**NO :** Repair or replace the connector. Refer to GROUP 00E, Harness Connector Inspection P.00E-2. Check that the air conditioning works normally.

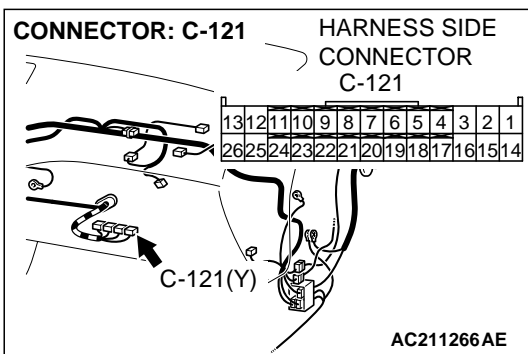

**STEP 31.** Check the wiring harness between A/C-ECU connector C-16 (terminal 5) and engine control module connector C-121 (terminal 24).

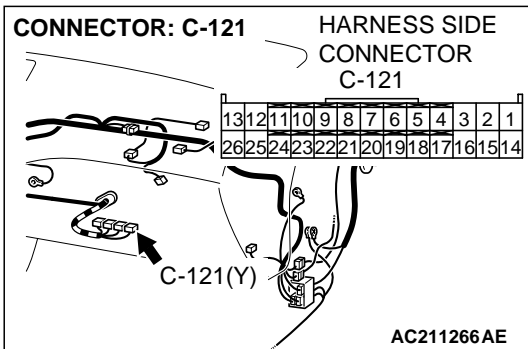
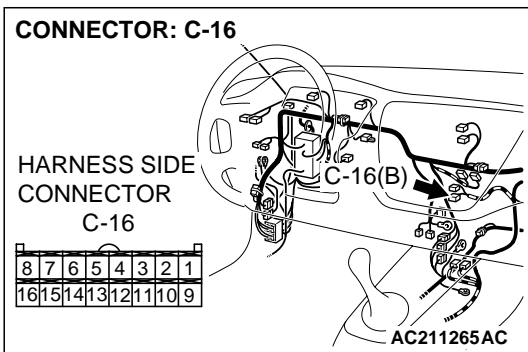

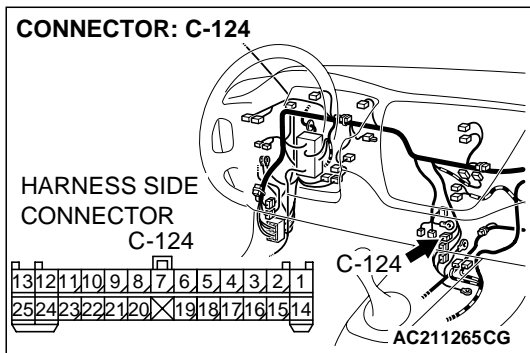

*NOTE: Also check intermediate connector C-124 for loose, corroded, or damaged terminals, or terminals pushed back in the connector. If intermediate connector C-124 is damaged, repair or replace the connector as described in GROUP 00E, Harness Connector Inspection P.00E-2.*

**Q: Is the wiring harness between A/C-ECU connector C-16 (terminal 5) and engine control module connector C-121 (terminal 24) in good condition?**

**YES :** Go to Step 32.

**NO :** Repair the wiring harness. Check that the air conditioning works normally.

---

**STEP 32. Check the refrigerant level.**

Use the refrigerant recovery station to remove all of the refrigerant, and then calculate the amount of the refrigerant and charge it.

**Q: Is the refrigerant level correct?**

**YES :** Go to Step 33.

**NO :** Correct the refrigerant level. (Refer to On-vehicle Service P.55-70) Check that the air conditioning works normally.

---

**STEP 33. Replace the A/C-ECU.**

**Q: Do the air conditioning work normally?**

**YES :** No action is necessary and testing is complete.

**NO :** Replace the engine control module connector. Check that the air conditioning works normally.

INSPECTION PROCEDURE 5: Blower Fan and Motor does not Turn.

Blower Motor Circuit

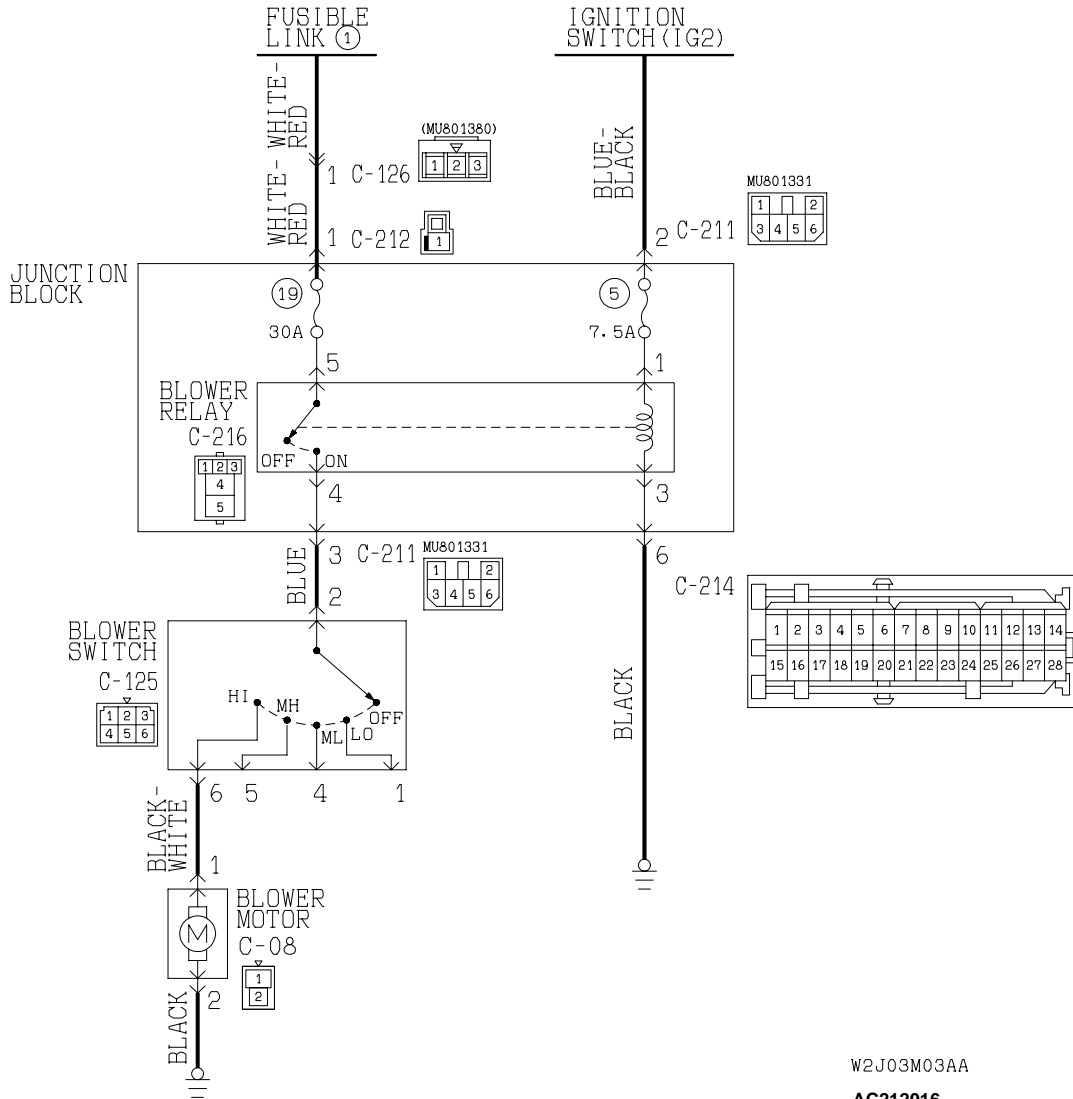

W2J03M03AA  
AC212016

CONNECTOR: C-08

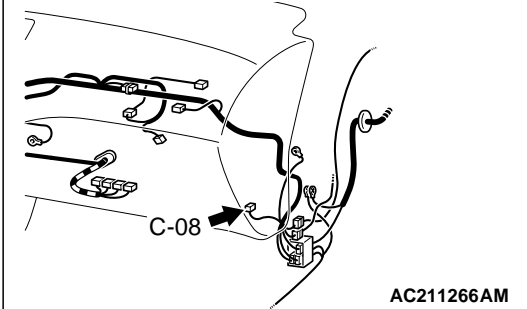

CONNECTORS: C-125, C-126

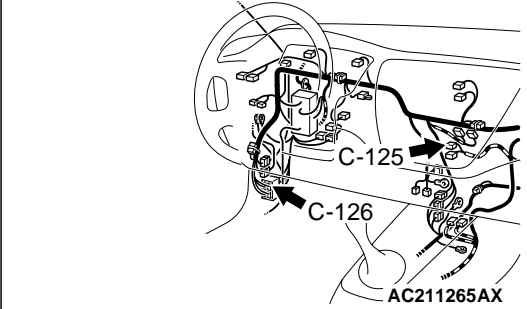

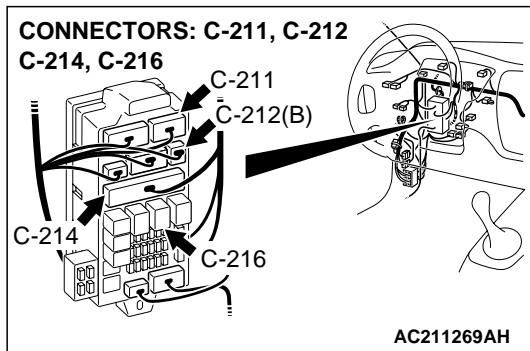

**TECHNICAL DESCRIPTION (COMMENT)**

If the blower fan and motor does not turn when the blower switch is operated, the blower switch may be defective.

**TROUBLESHOOTING HINTS**

- Malfunction of the blower relay
- Malfunction of the blower switch
- Malfunction of the blower motor
- The wiring harness or connectors may have loose, corroded, or damaged terminals, or terminals pushed back in the connector

**DIAGNOSIS**

**Required Special Tools:**

- MB991223: Test Harness Set

**STEP 1. Measure the voltage at blower motor connector C-08.**

- (1) Disconnect blower motor connector C-08, and measure the voltage at the wiring harness side.
- (2) Turn the ignition switch to the "ON" position.
- (3) Turn the blower switch to the "HI" position.

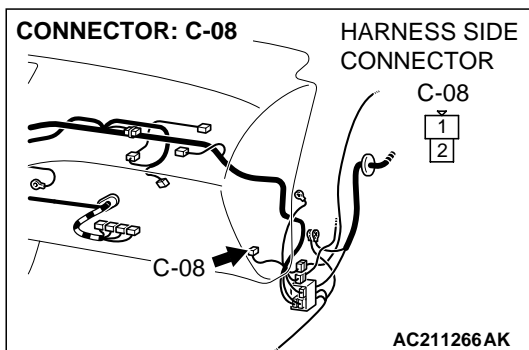

- (4) Measure the voltage between terminal 1 and ground.
  - The measured value should be approximately 12 volts (battery positive voltage).

**Q: Does the measured voltage correspond with this range?**

- YES :** Go to Step 17.  
**NO :** Go to Step 2.

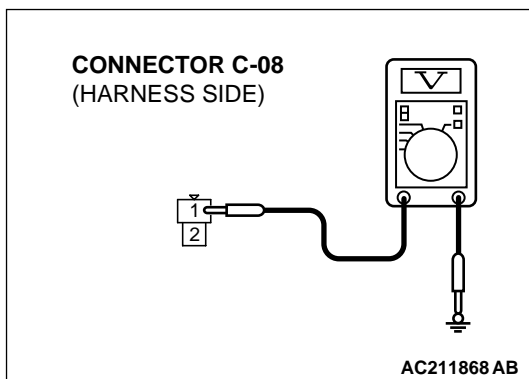

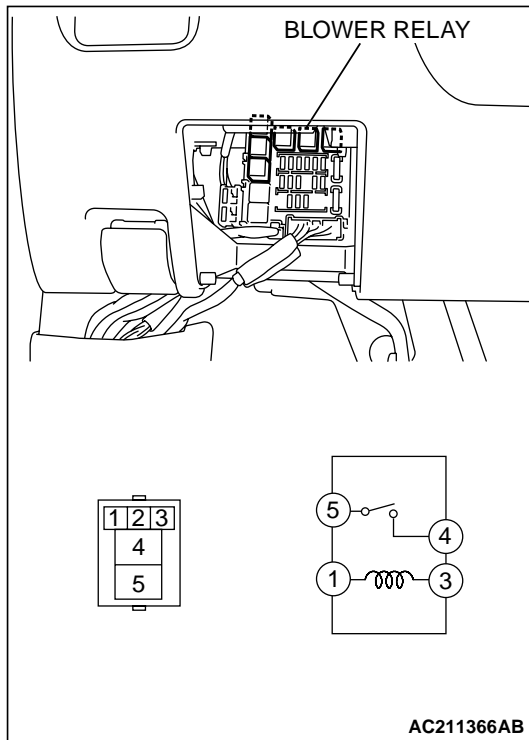
**STEP 2. Check the blower relay continuity.**

Follow the table below to check the blower relay for continuity.

BATTERY VOLTAGE	TESTER CONNECTION	SPECIFIED CONDITION
Not applied	4 – 5	Open circuit
<ul style="list-style-type: none"> <li>Connect terminal 1 to the positive battery terminal</li> <li>Connect terminal 3 to the negative battery terminal</li> </ul>	4 – 5	Less than 2 ohms

**Q: Is the blower relay continuity in good condition?**

**YES :** Go to Step 3.

**NO :** Replace the blower relay. The blower motor should operate normally.

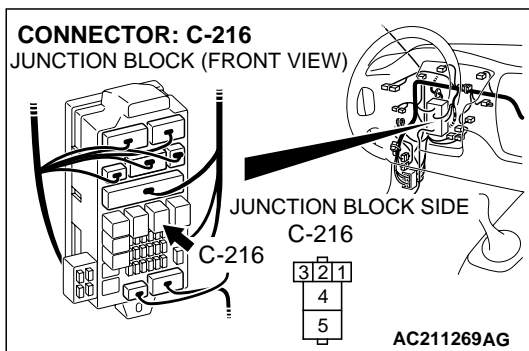
**STEP 3. Measure the voltage at blower relay connector C-216.**

- (1) Disconnect blower relay connector C-216, and measure the voltage at the junction block side.
- (2) Turn the ignition switch to the "ON" position.

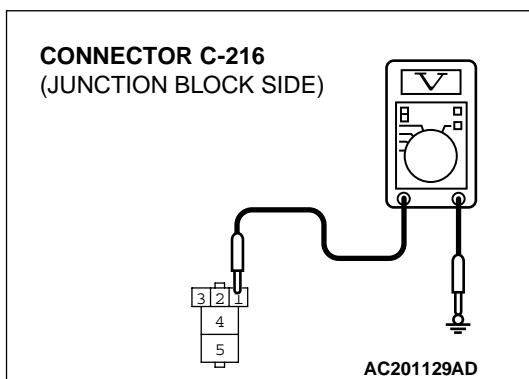

- (3) Measure the voltage between terminal 1 and ground.

- The measured value should be approximately 12 volts (battery positive voltage).

**Q: Does the measured voltage correspond with this range?**

**YES :** Go to Step 6.

**NO :** Go to Step 4.

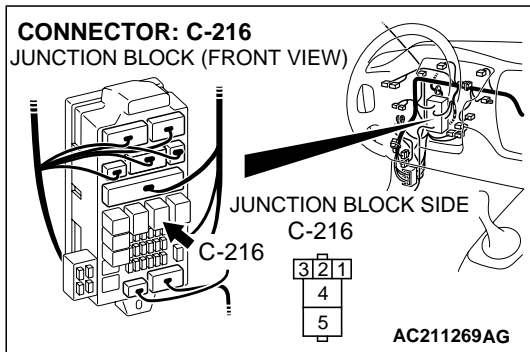

**STEP 4. Check blower relay connector C-216 for loose, corroded or damaged terminals, or terminals pushed back in the connector.**

**Q: Is blower relay connector C-216 in good condition?**

**YES :** Go to Step 5.

**NO :** Repair or replace the connector. Refer to GROUP 00E, Harness Connector Inspection [P.00E-2](#). The blower motor should operate normally.

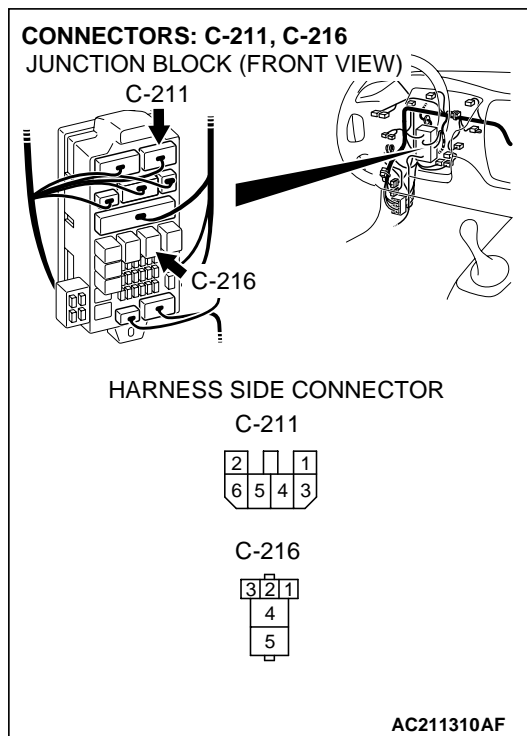

**STEP 5. Check the wiring harness between blower relay connector C-216 (terminal 1) and the ignition switch (IG2).**

*NOTE: Also check junction block connector C-211 for loose, corroded, or damaged terminals, or terminals pushed back in the connector. If junction block connector C-211 is damaged, repair or replace the connector as described in GROUP 00E, Harness Connector Inspection [P.00E-2](#).*

**Q: Is the wiring harness between blower relay connector C-216 (terminal 1) and the ignition switch (IG2) in good condition?**

**YES :** The blower motor should operate normally.

**NO :** Repair the wiring harness. The blower motor should operate normally.

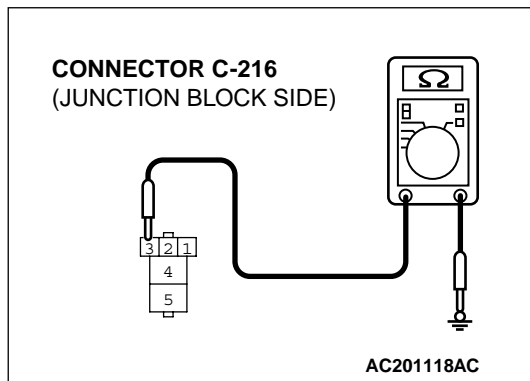
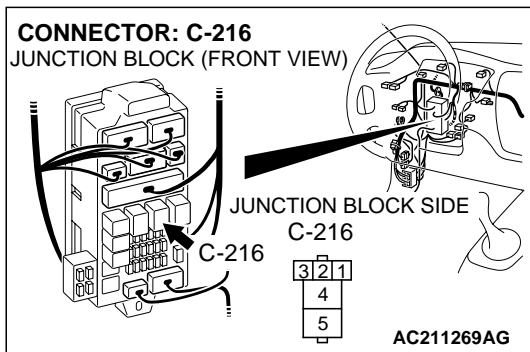

**STEP 6. Measure the resistance at blower relay connector C-216.**

(1) Disconnect connector C-216, and measure the resistance at the junction block side.

(2) Measure the resistance value between terminal 3 and ground.

- The measured value should be 2 ohms or less.

**Q: Does the measured resistance value correspond with this range?**

**YES :** Go to Step 9.

**NO :** Go to Step 7.

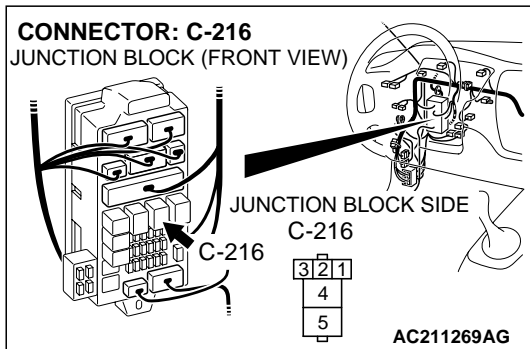

**STEP 7. Check blower relay connector C-216 for loose, corroded or damaged terminals, or terminals pushed back in the connector.**

**Q: Is blower relay connector C-216 in good condition?**

**YES :** Go to Step 8.

**NO :** Repair or replace the connector. Refer to GROUP 00E, Harness Connector Inspection [P.00E-2](#). The blower motor should operate normally.



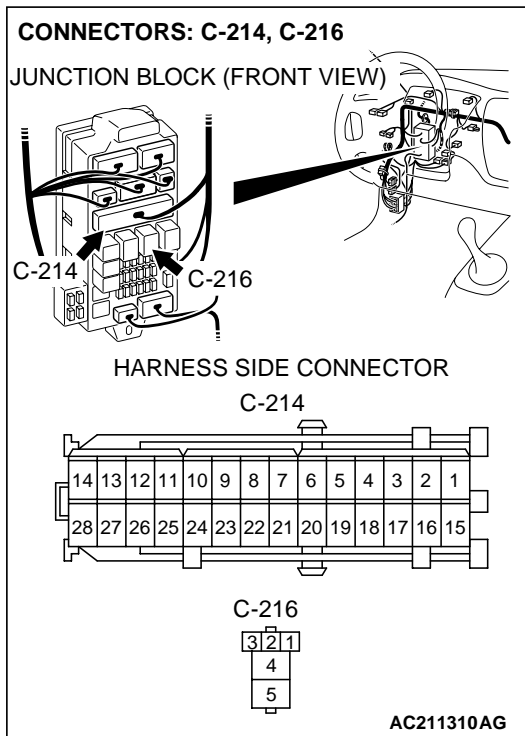

**STEP 8. Check the wiring harness between blower relay connector C-216 (terminal 3) and ground.**

*NOTE: Also check junction block connector C-214 for loose, corroded, or damaged terminals, or terminals pushed back in the connector. If junction block connector C-214 is damaged, repair or replace the connector as described in GROUP 00E, Harness Connector Inspection P.00E-2.*

**Q: Is the wiring harness between blower relay connector C-216 (terminal 3) and ground in good condition?**

**YES :** The blower motor should operate normally.

**NO :** Repair the wiring harness. The blower motor should operate normally.

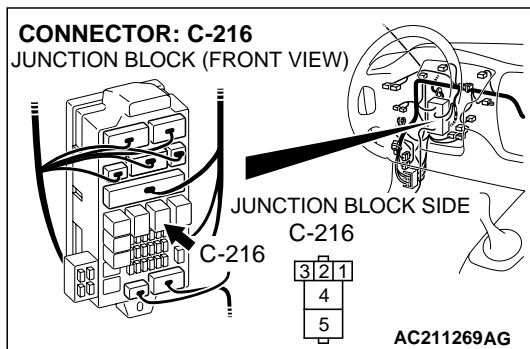

**STEP 9. Measure the voltage at blower relay connector C-216.**

(1) Disconnect blower relay connector C-216, and measure the voltage at the junction block side.

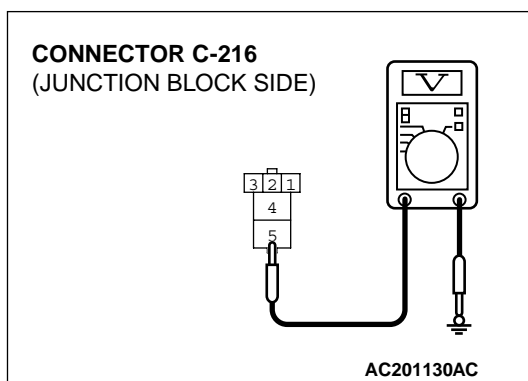

(2) Measure the voltage between terminal 5 and ground.

- The measured value should be approximately 12 volts (battery positive voltage).

**Q: Does the measured voltage correspond with this range?**

**YES :** Go to Step 12.

**NO :** Go to Step 10.

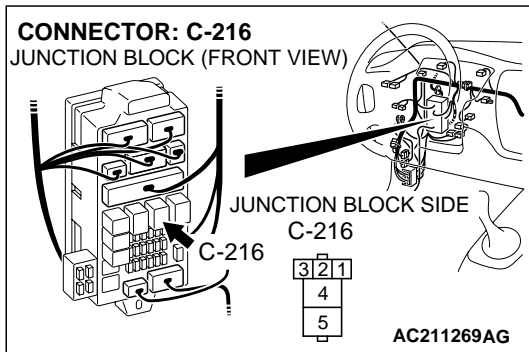

**STEP 10. Check blower relay connector C-216 for loose, corroded or damaged terminals, or terminals pushed back in the connector.**

**Q: Is blower relay connector C-216 in good condition?**

**YES :** Go to Step 11.

**NO :** Repair or replace the connector. Refer to GROUP 00E, Harness Connector Inspection [P.00E-2](#). The blower motor should operate normally.

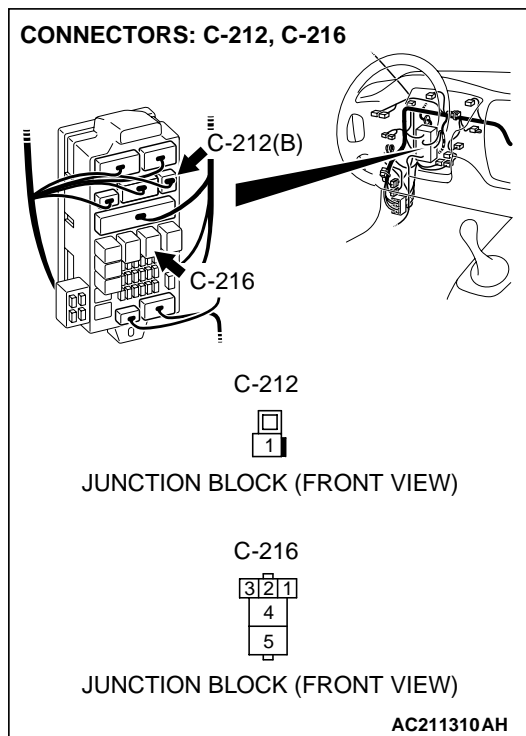

**STEP 11. Check the wiring harness between blower relay connector C-216 (terminal 5) and fusible link (1).**

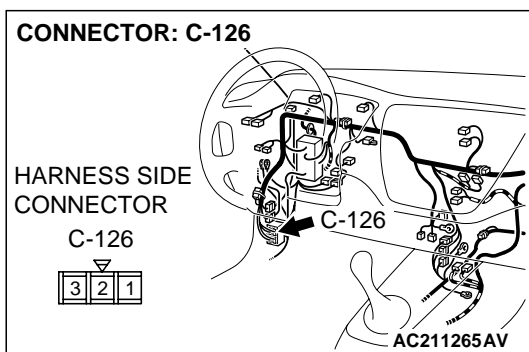

*NOTE: Also check intermediate connector C-126 and junction block connector C-212 for loose, corroded, or damaged terminals, or terminals pushed back in the connector. If intermediate connector C-126 and junction block connector C-212 is damaged, repair or replace the connector as described in GROUP 00E, Harness Connector Inspection [P.00E-2](#).*

**Q: Is the wiring harness between blower relay connector C-216 (terminal 5) and fusible link (1) in good condition?**

**YES :** The blower motor should operate normally.

**NO :** Repair the wiring harness. The blower motor should operate normally.

**STEP 12. Check blower switch connector C-125 and blower relay connector C-216 for loose, corroded or damaged terminals, or terminals pushed back in the connector.**

**Q: Is blower switch connector C-125 and blower relay connector C-216 in good condition?**

**YES :** Go to Step 13.

**NO :** Repair or replace the connector. Refer to GROUP 00E, Harness Connector Inspection P.00E-2. The blower motor should operate normally.

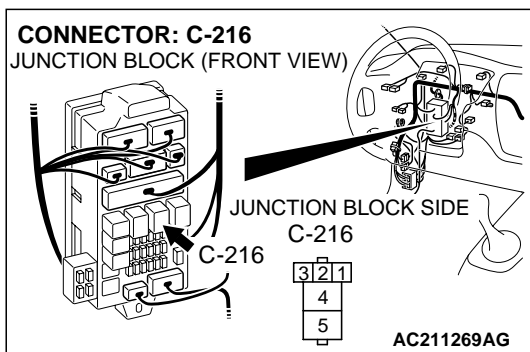
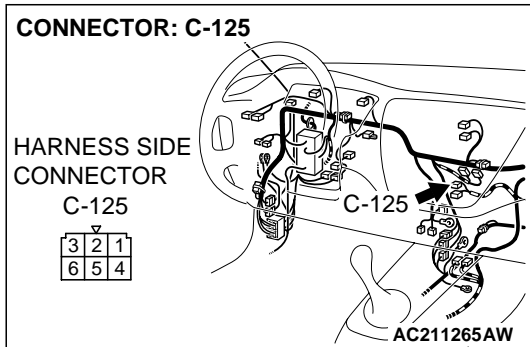

**STEP 13.** Check the wiring harness between blower switch connector C-125 (terminal 2) and blower relay connector C-216 (terminal 4).

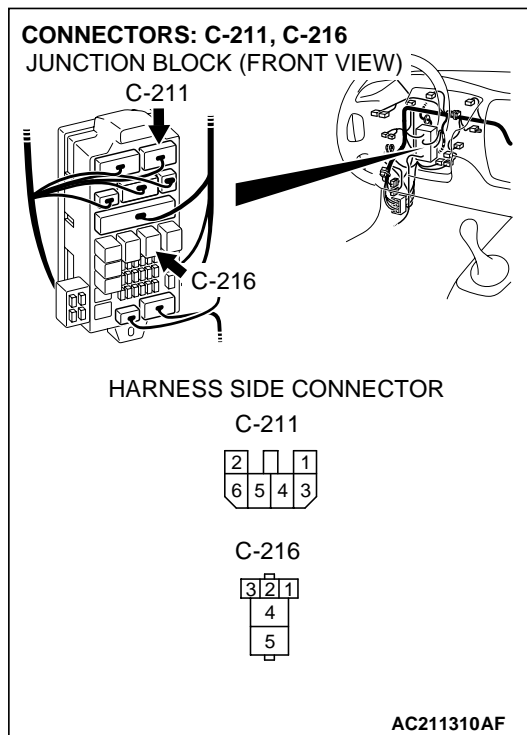
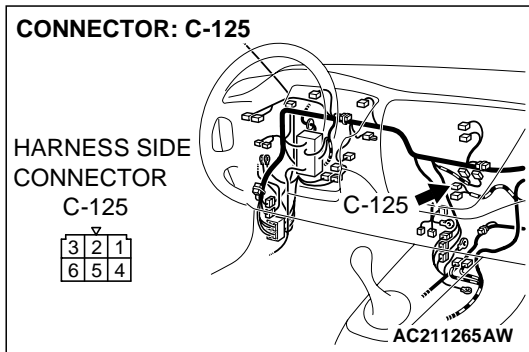

*NOTE:* Also check junction block connector C-211 for loose, corroded, or damaged terminals, or terminals pushed back in the connector. If junction block connector C-211 is damaged, repair or replace the connector as described in GROUP 00E, *Harness Connector Inspection* [P.00E-2](#).

**Q:** Is the wiring harness between blower switch connector C-125 (terminal 2) and blower relay connector C-216 (terminal 4) in good condition?

**YES :** Go to Step 14.

**NO :** Repair the wiring harness. The blower motor should operate normally.

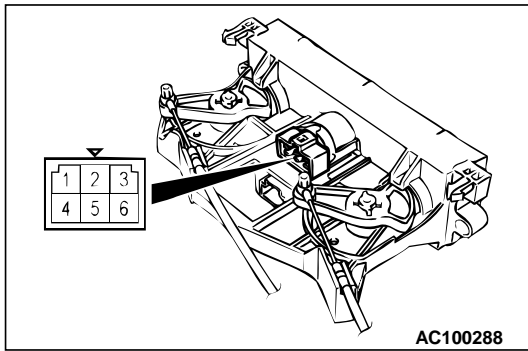

**STEP 14. Check the blower switch continuity.**

Follow the table below to check the blower switch for continuity.

SWITCH POSITION	TESTER CONNECTION (CONNECTOR A)	SPECIFIED CONDITION
0 (OFF)	1 – 2, 2 – 4, 2 – 5, 2 – 6	Open circuit
1 (LO)	1 – 2	Less than 2 ohms
2 (ML)	2 – 4	Less than 2 ohms
3 (MH)	2 – 5	Less than 2 ohms
4 (HI)	2 – 6	Less than 2 ohms

**Q: Is the blower switch continuity in good condition?**

**YES :** Go to Step 15.

**NO :** Replace the blower switch. The blower motor should operate normally.

**STEP 15. Check blower switch connector C-125 and blower motor connector C-08 for loose, corroded or damaged terminals, or terminals pushed back in the connector.**

**Q: Is blower switch connector C-125 and blower motor connector C-08 in good condition?**

**YES :** Go to Step 16.

**NO :** Repair or replace the connector. Refer to GROUP 00E, Harness Connector Inspection P.00E-2. The blower motor should operate normally.

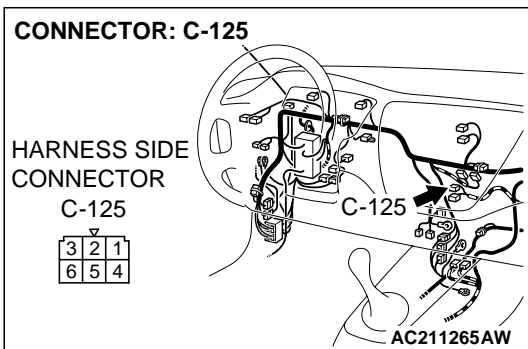
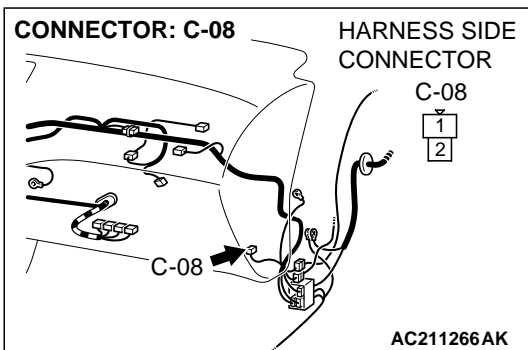

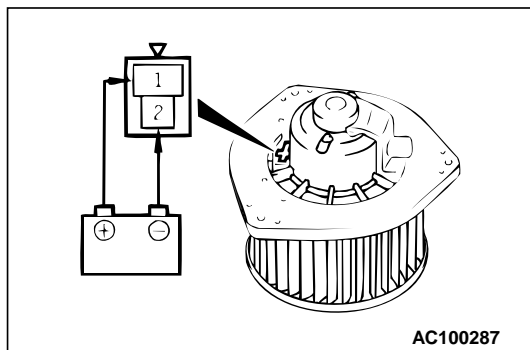
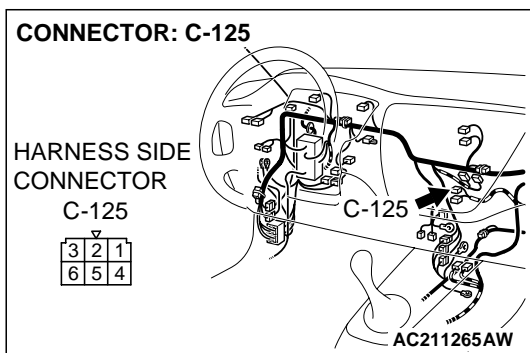
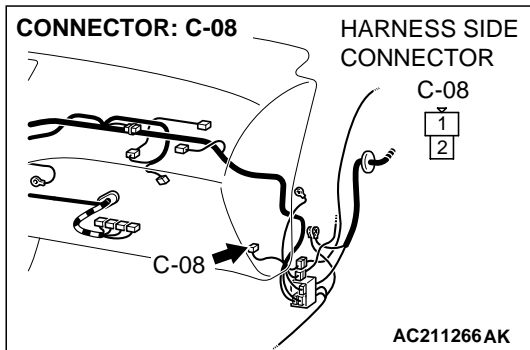

**STEP 16. Check the wiring harness between blower switch connector C-125 (terminal 6) and blower motor connector C-08 (terminal 1).**

**Q: Is the wiring harness between blower switch connector C-125 (terminal 6) and blower motor connector C-08 (terminal 1) in good condition?**

**YES :** The blower motor should operate normally.

**NO :** Repair the wiring harness. The blower motor should operate normally.

**STEP 17. Check the blower fan and motor operation.**

When battery voltage is applied between the terminals, check that the motor operates.

**Q: Is there any abnormal noise?**

**YES :** Go to Step 18.

**NO :** Replace the blower relay. The blower motor should operate normally.

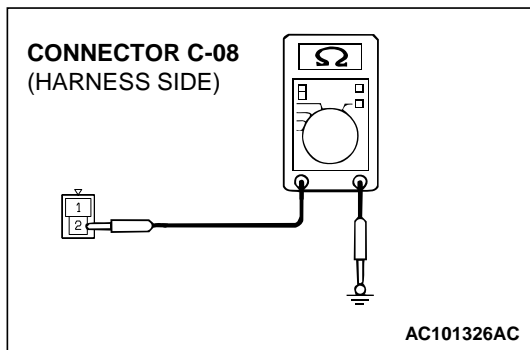
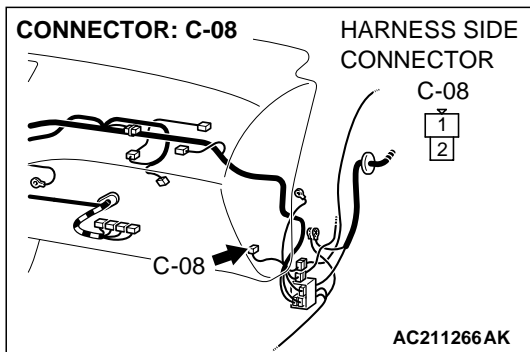

**STEP 18. Measure the resistance at blower motor connector C-08.**

(1) Disconnect blower motor connector C-08, and measure the voltage at the wiring harness side.

(2) Measure the resistance value between terminal 2 and ground.  
• The measured value should be 2 ohms or less.

**Q: Does the measured resistance value correspond with this range?**

**YES :** The blower motor should operate normally.  
**NO :** Go to Step 19.

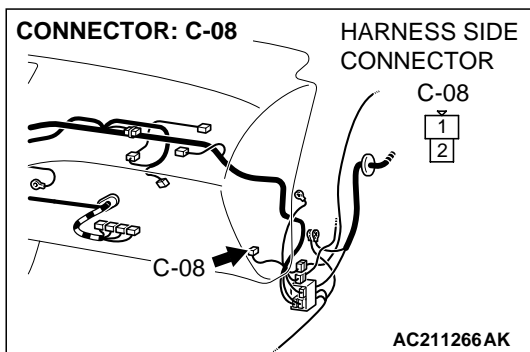

**STEP 19. Check blower motor connector C-08 for loose, corroded or damaged terminals, or terminals pushed back in the connector.**

**Q: Is blower motor connector C-08 in good condition?**

**YES :** Go to Step 20.  
**NO :** Repair or replace the connector. Refer to GROUP 00E, Harness Connector Inspection P.00E-2. The blower motor should operate normally.

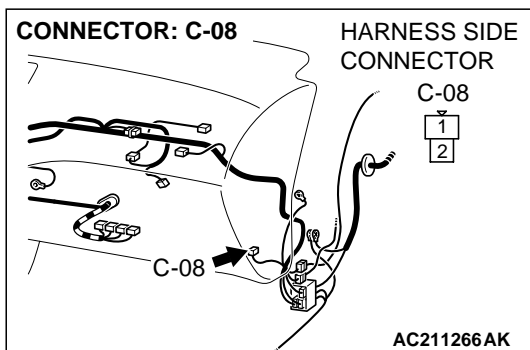

**STEP 20. Check the wiring harness between blower motor connector C-08 (terminal 2) and ground.**

**Q: Is the wiring harness between blower motor connector C-08 (terminal 2) and ground in good condition?**

**YES :** The blower motor should operate normally.  
**NO :** Repair the wiring harness. The blower motor should operate normally.





## DIAGNOSIS

### Required Special Tools:

- MB991223: Test Harness Set

---

### STEP 1. Check that the blower motor operates when the blower switch is moved to the "HI" position.

- (1) Turn the ignition switch to the "ON" position.
- (2) Turn the blower switch to the "HI" position.

### Q: Does the blower motor operate when the blower switch is moved to the "HI" position?

- YES** : Go to STEP 4.  
**NO** : Go to STEP 2.

---

### STEP 2. Check blower switch connector C-125 and blower motor connector C-08 for loose, corroded or damaged terminals, or terminals pushed back in the connector.

### Q: Are blower switch connector C-125 and blower motor connector C-08 in good condition?

- YES** : Go to Step 3.  
**NO** : Repair or replace the connector. Refer to GROUP 00E, Harness Connector Inspection [P.00E-2](#). The blower motor should operate normally.

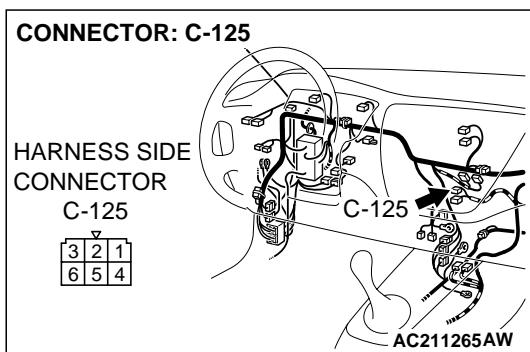
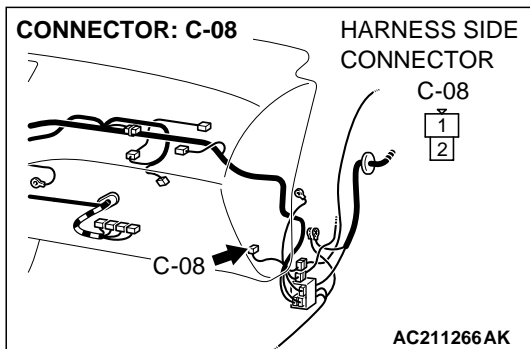

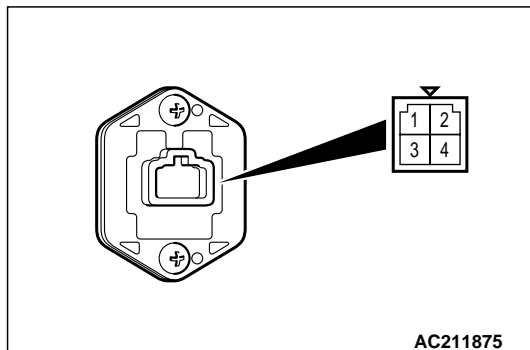
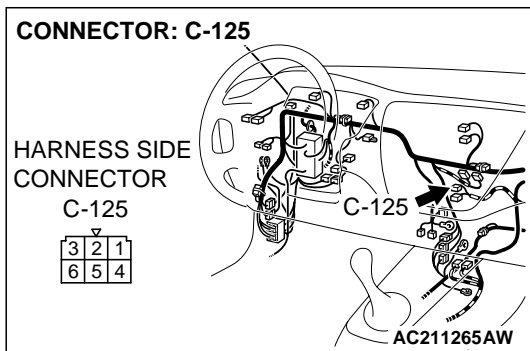
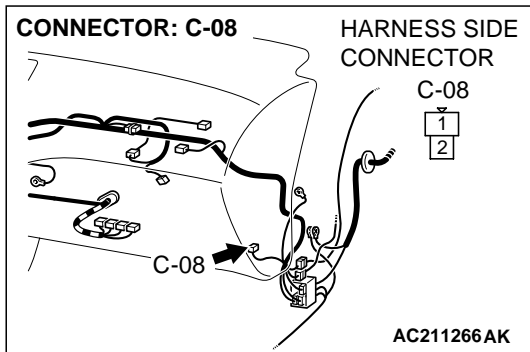

**STEP 3. Check the wiring harness between blower switch connector C-125 (terminal 6) and blower motor connector C-08 (terminal 1).**

**Q: Is the wiring harness between blower switch connector C-125 (terminal 6) and blower motor connector C-08 (terminal 1) in good condition?**

**YES :** The blower motor should operate normally.

**NO :** Repair the wiring harness. The blower motor should operate normally.

**STEP 4. Check the resistor resistance value.**

Use an ohmmeter to measure the resistance between the terminals as indicated below. Check that the measured value is at the standard value.

**Standard value:**

MEASUREMENT TERMINAL	STANDARD VALUE $\Omega$
Between terminals 2 and 4 (LO)	2.54
Between terminals 1 and 2 (ML)	1.24
Between terminals 3 and 2 (MH)	0.6

**Q: Is the measured value at the standard value?**

**YES :** Go to Step 5.

**NO :** Replace the resistor. The blower motor should operate normally.

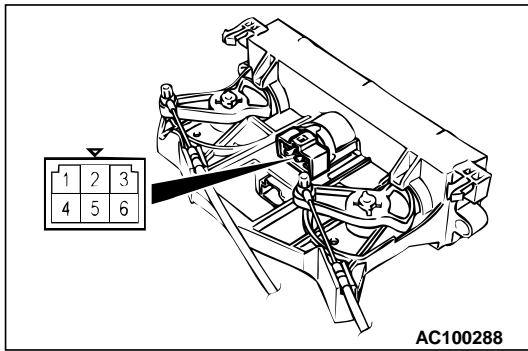

**STEP 5. Check the blower switch continuity.**

Follow the table below to check the blower switch for continuity.

SWITCH POSITION	TESTER CONNECTION (CONNECTOR A)	SPECIFIED CONDITION
0 (OFF)	1 – 2, 2 – 4, 2 – 5, 2 – 6	Open circuit
1 (LO)	1 – 2	Less than 2 ohms
2 (ML)	2 – 4	Less than 2 ohms
3 (MH)	2 – 5	Less than 2 ohms
4 (HI)	2 – 6	Less than 2 ohms

**Q: Is the blower switch continuity in good condition?**

**YES :** Go to Step 6.

**NO :** Replace the blower switch. The blower motor should operate normally.

**STEP 6. Check blower switch connector C-125 and resistor connector C-09 for loose, corroded or damaged terminals, or terminals pushed back in the connector.**

**Q: Are blower switch connector C-125 and resistor connector C-09 in good condition?**

**YES :** Go to Step 7.

**NO :** Repair or replace the connector. Refer to GROUP 00E, Harness Connector Inspection [P.00E-2](#). The blower motor should operate normally.

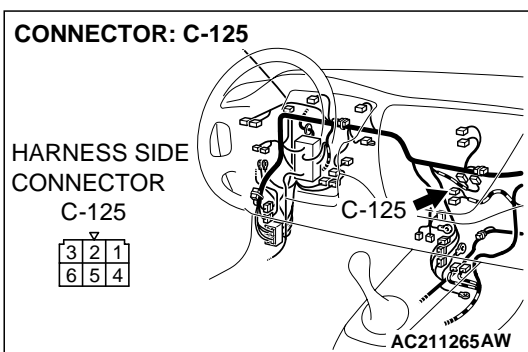
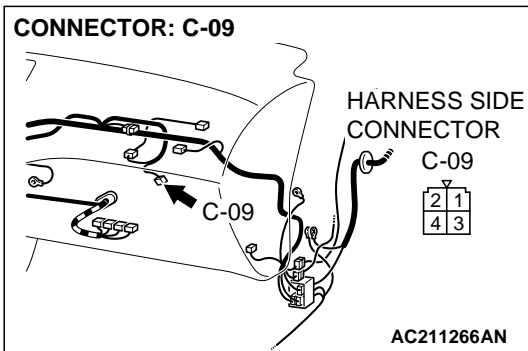

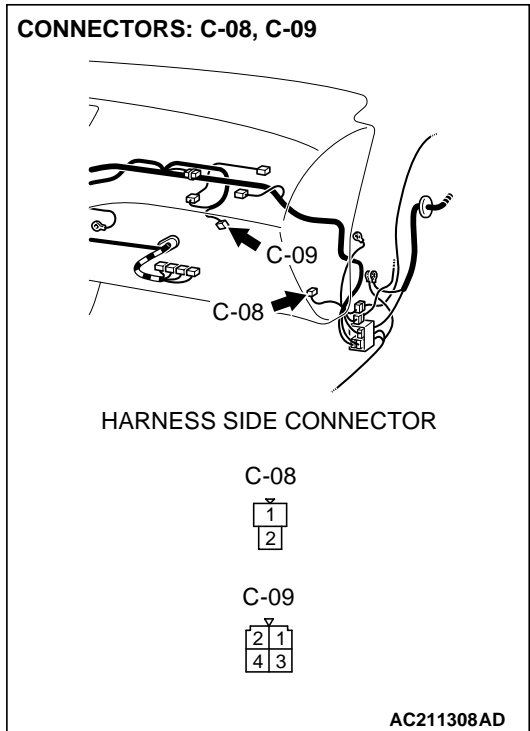
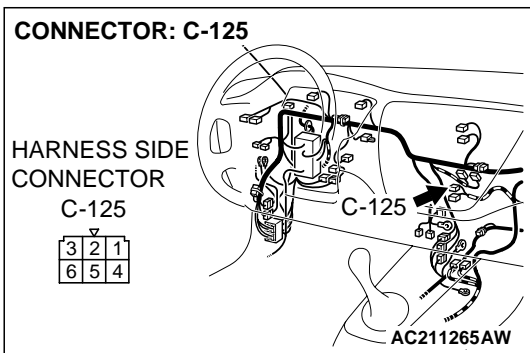
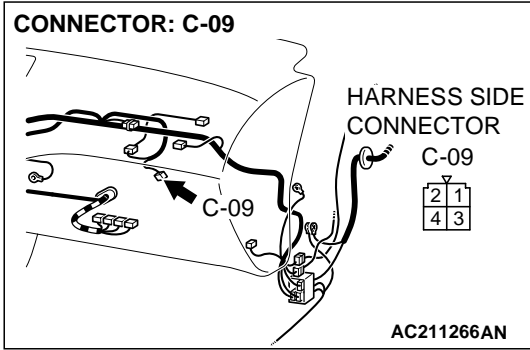

**STEP 7. Check the wiring harness between blower switch connector C-125 (terminals 1, 4 and 5) and resistor connector C-09(terminal 4, 1 and 3).**

**Q: Is the wiring harness between blower switch connector C-125 (terminals 1, 4 and 5) and resistor connector C-09(terminal 4, 1 and 3) in good condition?**

**YES :** Go to Step 8.

**NO :** Repair the wiring harness. The blower motor should operate normally.

**STEP 8. Check resistor connector C-09 and blower motor connector C-08 for loose, corroded or damaged terminals, or terminals pushed back in the connector.**

**Q: Are resistor connector C-09 and blower motor connector C-08 in good condition?**

**YES :** Go to Step 9.

**NO :** Repair or replace the connector. Refer to GROUP 00E, Harness Connector Inspection [P.00E-2](#). The blower motor should operate normally.

CONNECTORS: C-08, C-09

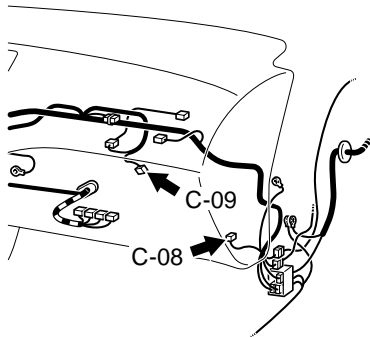

HARNESS SIDE CONNECTOR

C-08



C-09



AC211308AD

**STEP 9. Check the wiring harness between blower motor connector C-08 (terminal 1) and resistor connector C-09 (terminal 2).**

**Q: Is the wiring harness between blower motor connector C-08 (terminal 1) and resistor connector C-09 (terminal 2) in good condition?**

**YES :** No action to be taken.

**NO :** Repair the wiring harness. The blower motor should operate normally.

INSPECTION PROCEDURE 7: Defroster Function does not Operate.

Defogger Circuit

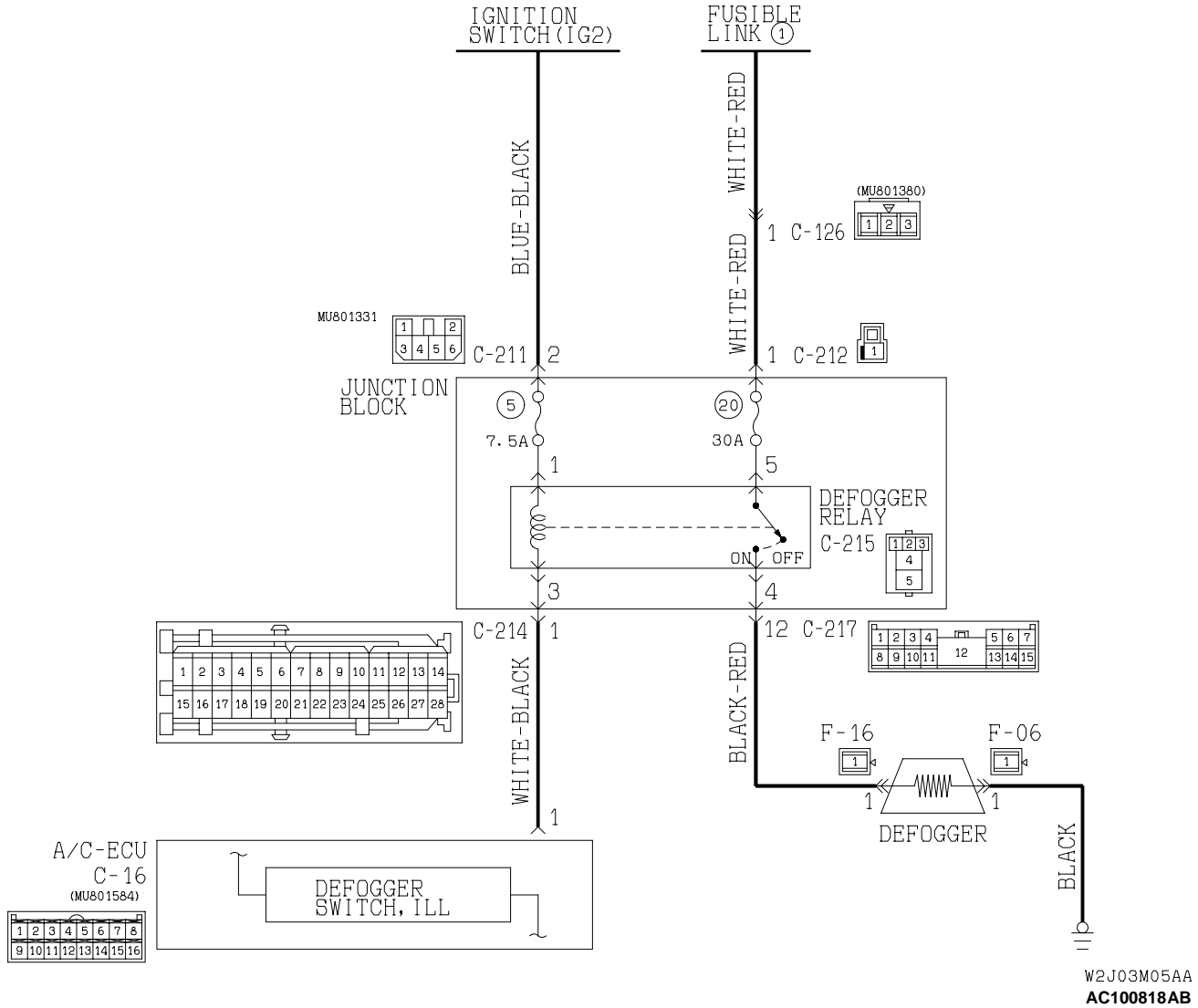

W2J03M05AA  
AC100818AB

CONNECTORS: C-16, C-126

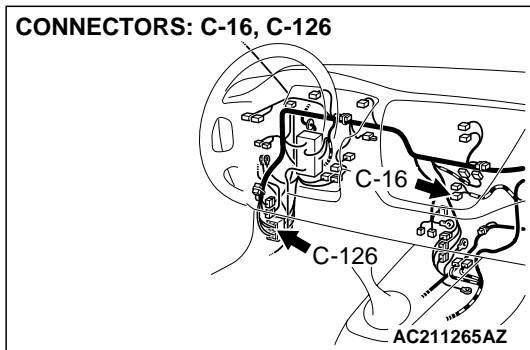

CONNECTORS: C-211, C-212  
C-214, C-215, C-217

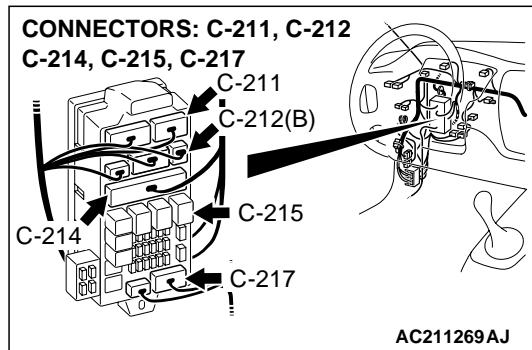

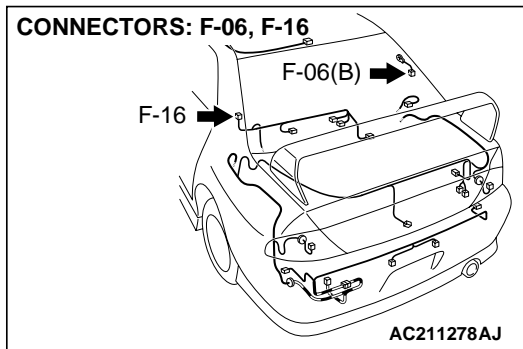

**TECHNICAL DESCRIPTION (COMMENT)**

If the defogger does not operate when the defogger switch is turned on, the defogger relay system may be defective.

**TROUBLESHOOTING HINTS**

- Malfunction of the A/C-ECU
- Malfunction of the defogger relay
- The wiring harness or connectors may have loose, corroded, or damaged terminals, or terminals pushed back in the connector

**DIAGNOSIS**

**Required Special Tools:**

- MB991223: Test Harness Set

**STEP 1. Check the A/C and outside/inside air selection damper control motor operation.**

**Q: Do the A/C and outside/inside air changeover damper control motor work normally?**

**YES :** Go to Step 2.

**NO :** Refer to Inspection procedure 10 "Malfunction of the A/C-ECU Power Supply system P.55-65."

**STEP 2. Measure the voltage at defogger connector F-16.**

- (1) Disconnect defogger connector F-16, and measure the voltage at the junction block side.
- (2) Turn the ignition switch to the "ON" position.
- (3) Turn the defogger switch to the "ON" position.

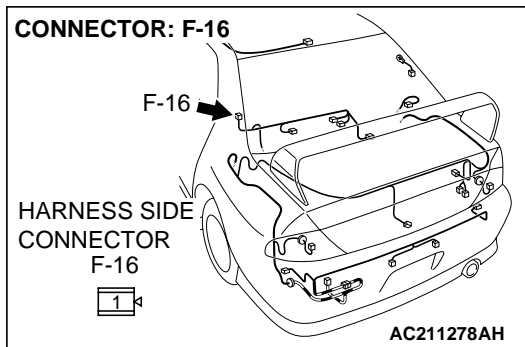

- (4) Measure the voltage between terminal 1 and ground.
  - The measured value should be approximately 12 volts (battery positive voltage).

**Q: Does the measured voltage correspond with this range?**

**YES :** Go to Step 14.

**NO :** Go to Step 3.

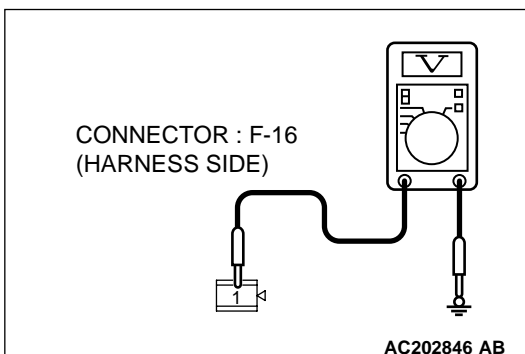

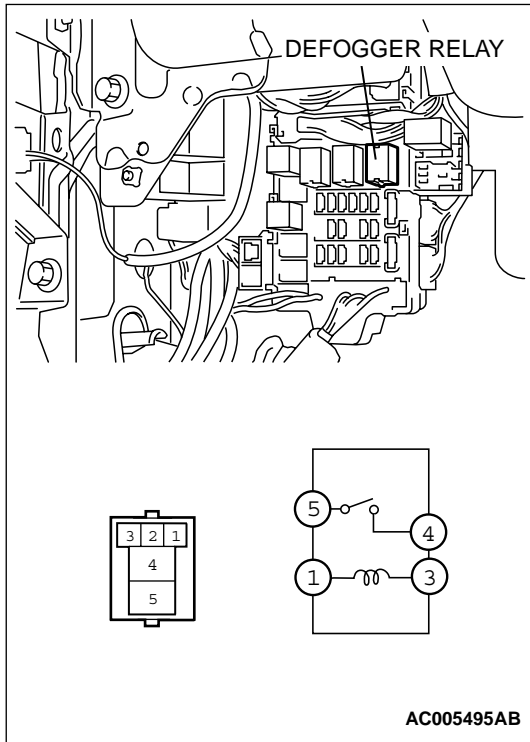

**STEP 3. Check the defogger relay continuity.**

Follow the table below to check the defogger relay for continuity.

BATTERY VOLTAGE	TESTER CONNECTION	SPECIFIED CONDITION
Not applied	4 – 5	Open circuit
<ul style="list-style-type: none"> <li>Connect terminal 1 to the positive battery terminal</li> <li>Connect terminal 3 to the negative battery terminal</li> </ul>	4 – 5	Less than 2 ohms

**Q: Is the Defogger relay continuity in good condition?**

**YES :** Go to Step 4.

**NO :** Replace the defogger relay. The defogger system should work normally.

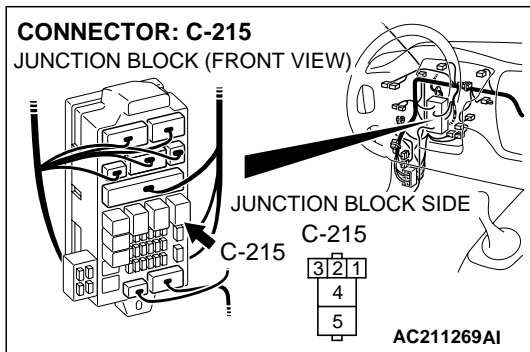

**STEP 4. Measure the voltage at defogger relay connector C-215.**

(1) Disconnect defogger relay connector C-215, and measure the voltage at the junction block side.

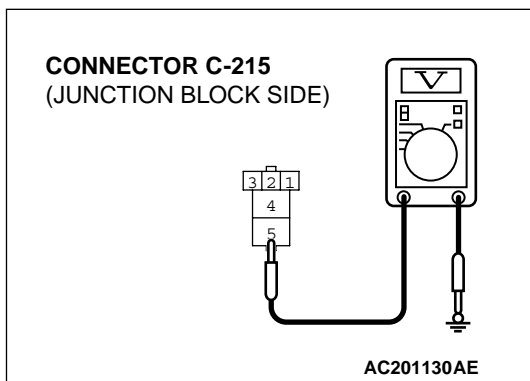

(2) Measure the voltage between terminal 5 and ground.

- The measured value should be approximately 12 volts (battery positive voltage).

**Q: Does the measured voltage correspond with this range?**

**YES :** Go to Step 7.

**NO :** Go to Step 5.



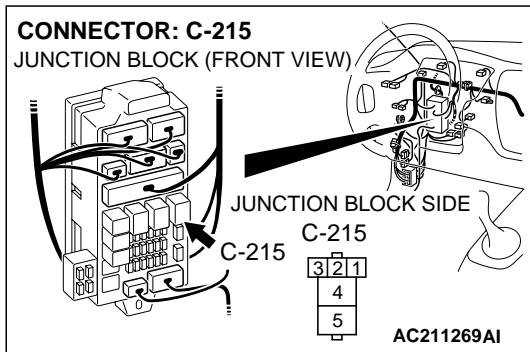

**STEP 5.** Check defogger relay connector C-215 for loose, corroded or damaged terminals, or terminals pushed back in the connector.

**Q:** Is defogger relay connector C-215 in good condition?

**YES :** Go to Step 6.

**NO :** Repair or replace the connector. Refer to GROUP 00E, Harness Connector Inspection [P.00E-2](#). The defogger system should work normally.

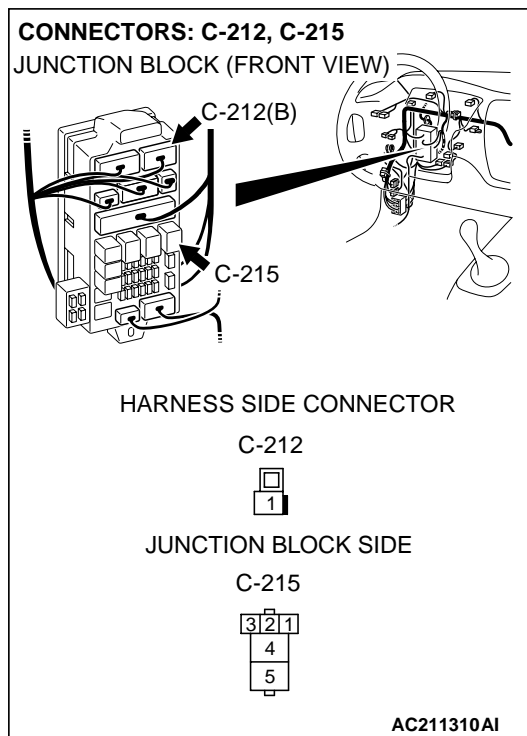

**STEP 6.** Check the wiring harness between defogger relay connector C-215 (terminal 5) and the battery.

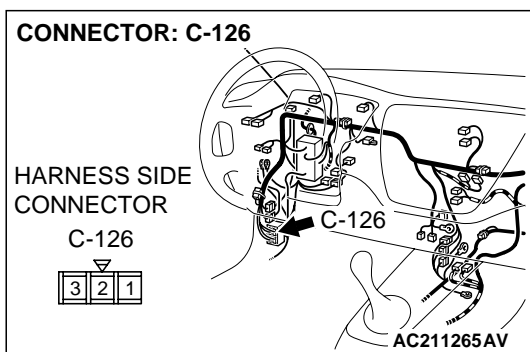

*NOTE:* Also check junction block connector C-212 and intermediate connector C-126 for loose, corroded, or damaged terminals, or terminals pushed back in the connector. If junction block connector C-212 and intermediate connector C-126 is damaged, repair or replace the connector as described in GROUP 00E, Harness Connector Inspection [P.00E-2](#).

**Q:** Is the wiring harness between defogger relay connector C-215 (terminal 5) and the battery in good condition?

**YES :** Check that the defogger system works normally.

**NO :** Repair the wiring harness. Check that the defogger system works normally.

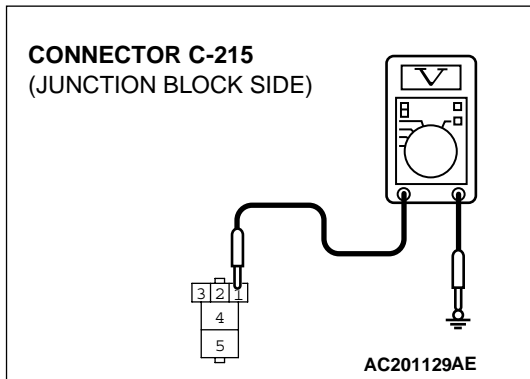
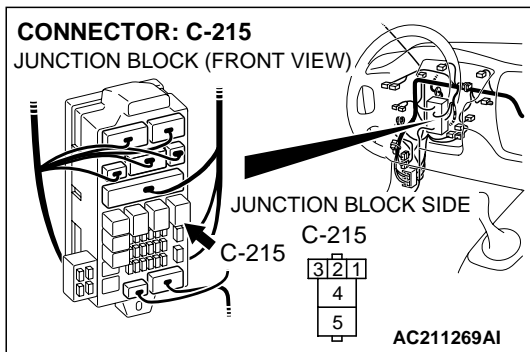
**STEP 7. Measure the voltage at defogger relay connector C-215.**

- (1) Disconnect defogger relay connector C-215, and measure the voltage at the junction block side.
- (2) Turn the ignition switch to the "ON" position.

- (3) Measure the voltage between terminal 1 and ground.
  - The measured value should be approximately 12 volts (battery positive voltage).

**Q: Does the measured voltage correspond with this range?**

**YES :** Go to Step 10.

**NO :** Go to Step 8.

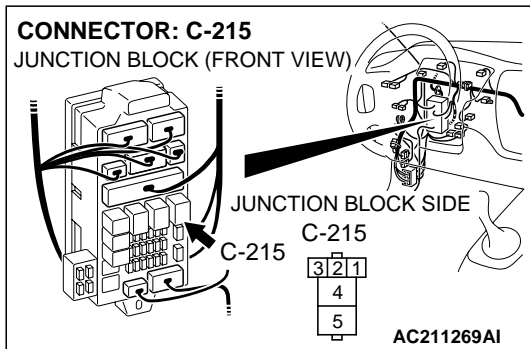
**STEP 8. Check defogger relay connector C-215 for loose, corroded or damaged terminals, or terminals pushed back in the connector.**

**Q: Is defogger relay connector C-215 in good condition?**

**YES :** Go to Step 9.

**NO :** Repair or replace the connector. Refer to GROUP 00E, Harness Connector Inspection [P.00E-2](#). Check that the defogger system works normally.

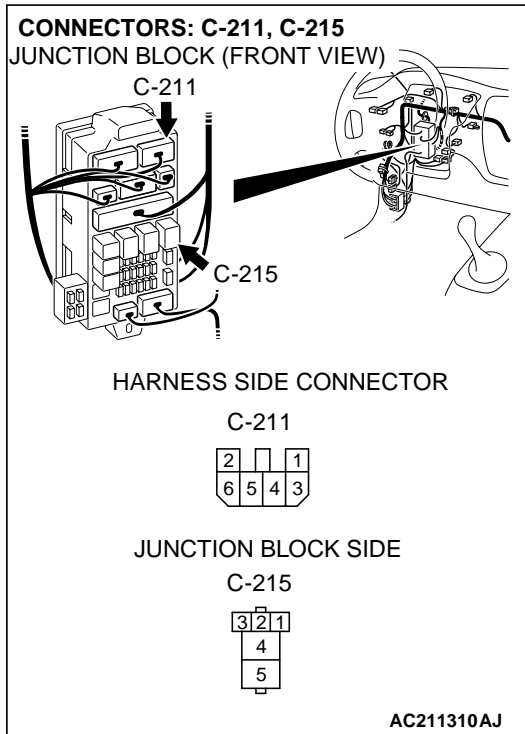

**STEP 9.** Check the wiring harness between defogger relay connector C-215 (terminal 1) and ignition switch (IG2).

*NOTE:* Also check junction block connector C-211 for loose, corroded, or damaged terminals, or terminals pushed back in the connector. If junction block connector C-211 is damaged, repair or replace the connector as described in GROUP 00E, *Harness Connector Inspection P.00E-2*.

**Q:** Is the wiring harness between defogger relay connector C-215 (terminal 1) and ignition switch (IG2) in good condition?

**YES :** Check that the defogger system works normally.

**NO :** Repair the wiring harness. Check that the defogger system works normally.

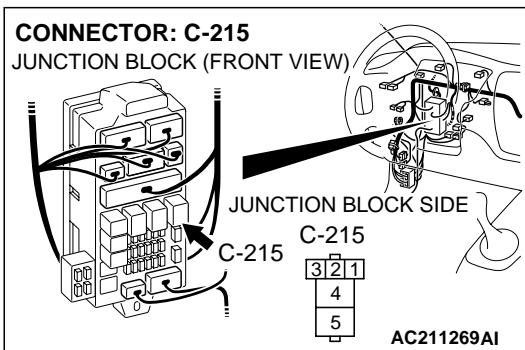

**STEP 10.** Check defogger relay connector C-215 and defogger connector F-16 for loose, corroded or damaged terminals, or terminals pushed back in the connector.

**Q:** Are defogger relay connector C-215 and defogger connector F-16 in good condition?

**YES :** Go to Step 11.

**NO :** Repair or replace the connector. Refer to GROUP 00E, *Harness Connector Inspection P.00E-2*. Check that the defogger system works normally.

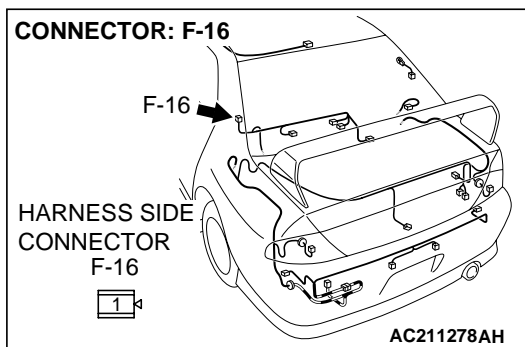

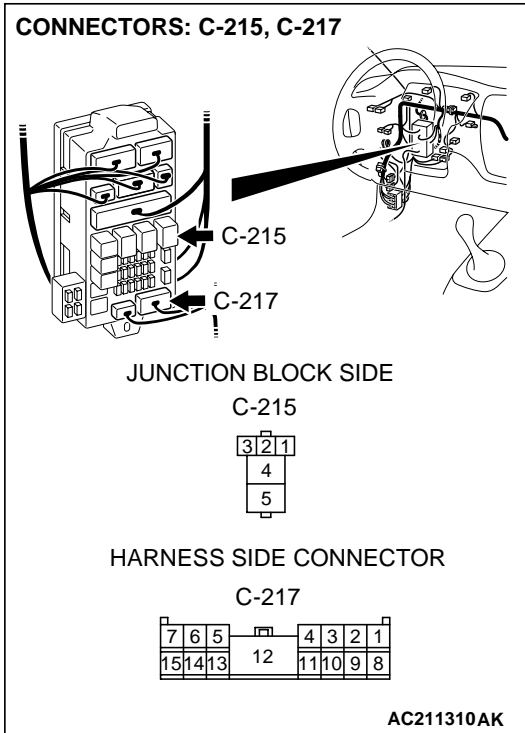

**STEP 11.** Check the wiring harness between defogger relay connector C-215 (terminal 4) and defogger connector F-16 (terminal 1).

*NOTE:* Also check junction block connector C-217 for loose, corroded, or damaged terminals, or terminals pushed back in the connector. If junction block connector C-217 is damaged, repair or replace the connector as described in GROUP 00E, Harness Connector Inspection P.00E-2.

**Q:** Is the wiring harness between defogger relay connector C-215 (terminal 4) and defogger connector F-16 (terminal 1) in good condition?

**YES :** Go to Step 12.

**NO :** Repair or replace the wiring harness. Refer to GROUP 00E, Harness Connector Inspection P.00E-2. Check that the defogger system works normally.

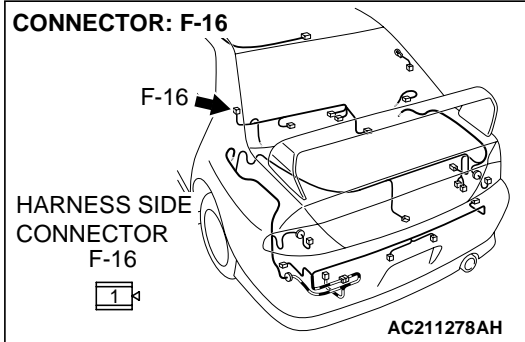

**STEP 12.** Check defogger relay connector C-215 and A/C-ECU connector C-16 for loose, corroded or damaged terminals, or terminals pushed back in the connector.

**Q:** Are defogger relay connector C-215 and A/C-ECU connector C-16 in good condition?

**YES :** Go to Step 13.

**NO :** Repair or replace the connector. Refer to GROUP 00E, Harness Connector Inspection [P.00E-2](#). Check that the defogger system works normally.

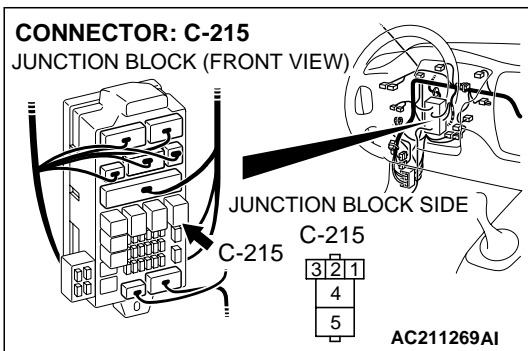
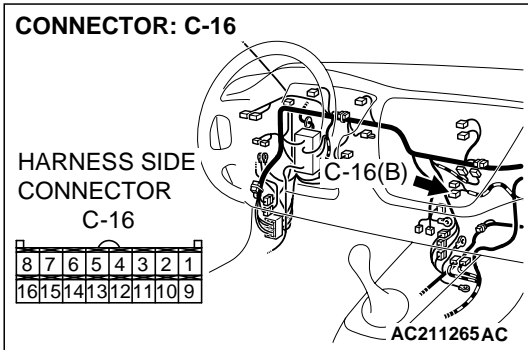

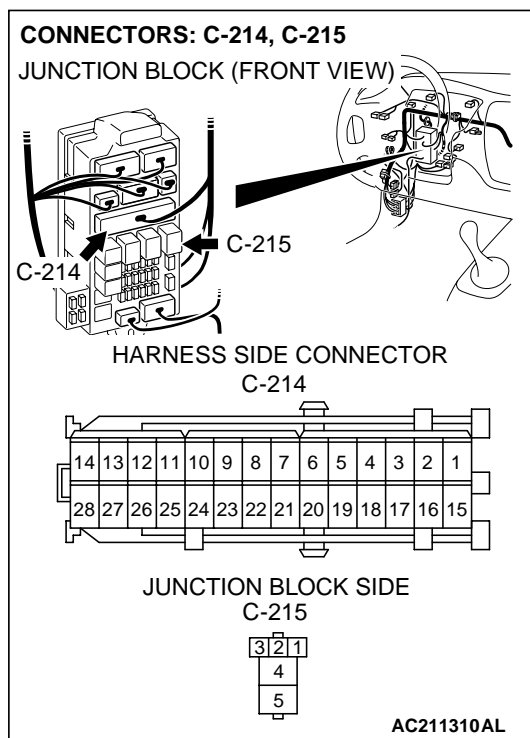
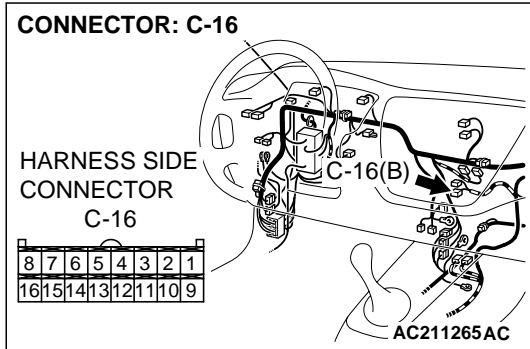

**STEP 13.** Check the wiring harness between defogger relay connector C-215 (terminal 3) and A/C-ECU connector C-16 (terminal 1).

*NOTE:* Also check junction block connector C-214 for loose, corroded, or damaged terminals, or terminals pushed back in the connector. If junction block connector C-214 is damaged, repair or replace the connector as described in GROUP 00E, *Harness Connector Inspection P.00E-2.*

**Q:** Is the wiring harness between defogger relay connector C-215 (terminal 3) and A/C-ECU connector C-16 (terminal 1) in good condition?

**YES :** Replace the A/C-ECU. The defogger should operate normally.

**NO :** Repair or replace the wiring harness. Refer to GROUP 00E, *Harness Connector Inspection P.00E-2.* Check that the defogger system works normally.

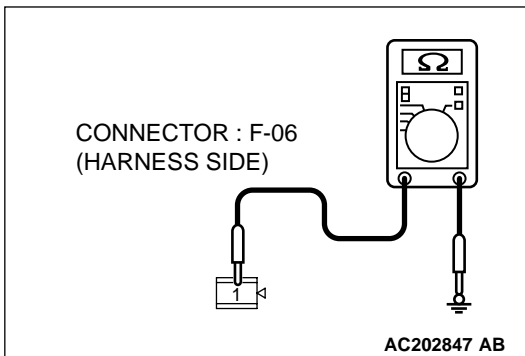
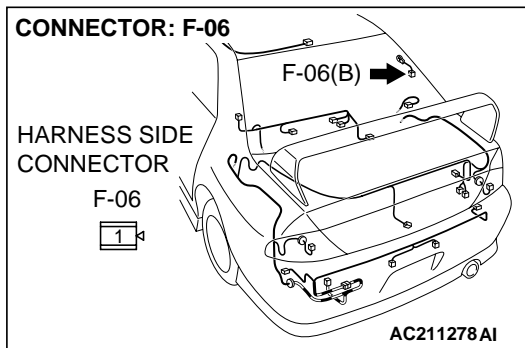

**STEP 14. Measure at defogger connector F-06 in order to check the ground circuit to the defogger connector.**

(1) Disconnect defogger connector F-06, and measure at the wiring harness side.

(2) Measure the resistance value between terminal 1 and ground.

- The measured value should be 2 ohms or less.

**Q: Does the measured resistance value correspond with this range?**

**YES :** Go to Step 17.

**NO :** Go to Step 15.

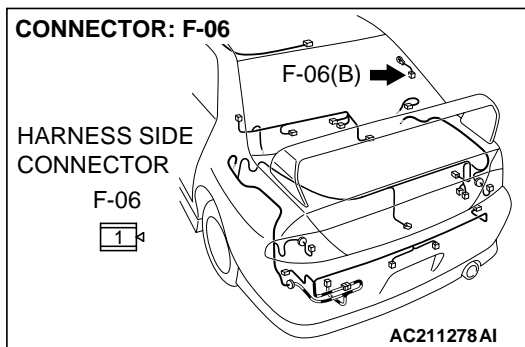

**STEP 15. Check defogger connector F-06 for loose, corroded or damaged terminals, or terminals pushed back in the connector.**

**Q: Is defogger connector F-06 in good condition?**

**YES :** Go to Step 16.

**NO :** Repair or replace the connector. Refer to GROUP 00E, Harness Connector Inspection [P.00E-2](#). Check that the defogger system works normally.

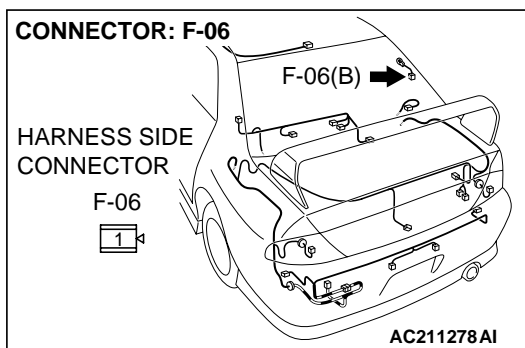

**STEP 16. Check the wiring harness between defogger connector F-06 (terminal 1) and ground.**

**Q: Is the wiring harness between defogger connector F-06 (terminal 1) and ground in good condition?**

**YES :** Check that the defogger system works normally.

**NO :** Repair or replace the wiring harness. Refer to GROUP 00E, Harness Connector Inspection [P.00E-2](#). Check that the defogger system works normally.

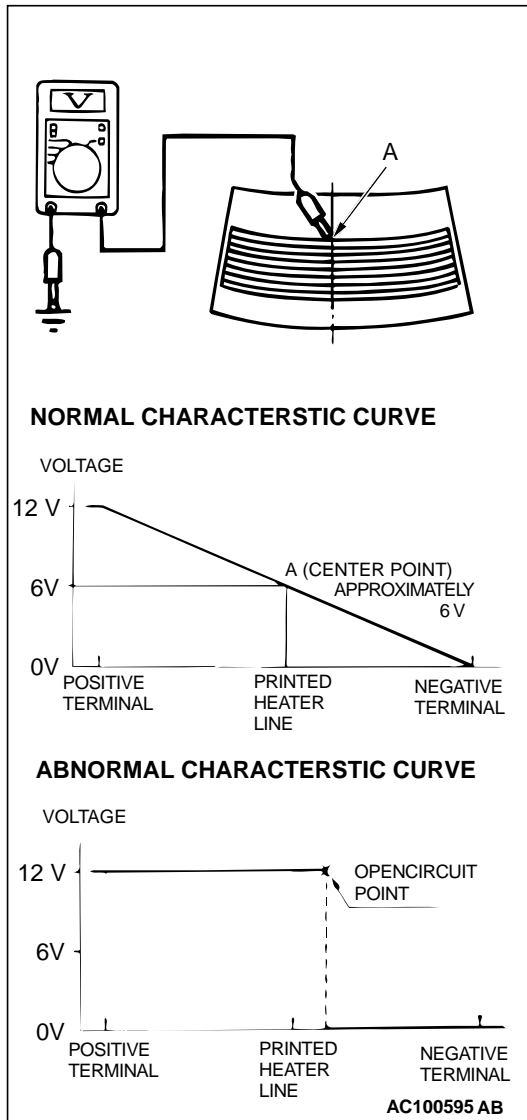
**STEP 17. Check the defogger.**

- (1) Let the engine run at 2,000 r/min, and check the printed heater with the battery fully charged.
- (2) Turn on the defogger switch, and use a voltmeter to measure the voltage in each printed heater at middle point A on the rear window glass.
  - The value should be approximately 6 volts.

**Q: Does the defogger work normally?**

- YES :** Check that the defogger system works normally.
- NO :** Repair the defogger.

**INSPECTION PROCEDURE 8: Defogger Timer Function does not Operate.****TECHNICAL DESCRIPTION (COMMENT)**

Turn ON the defogger switch. If the defogger does not shut off after roughly 11 minutes then the defogger timer is malfunctioning.

**TROUBLESHOOTING HINTS**

- Malformation of the A/C-ECU

**Step 1. Check the performance of the defogger timer operations.**

- (1) Turn the ignition switch to the "ON" position.
- (2) Turn the defogger switch to the "ON" position. (operate for approx. 11 minutes)

**Q: Does the defogger timer function work normally?**

- YES :** Intermittent malfunction
- NO :** Replace the A/C-ECU. Check that the defogger timer function works normally.



INSPECTION PROCEDURE 9: Malfunction of the A/C-ECU Power Supply System.

A/C-ECU Power Supply Circuit

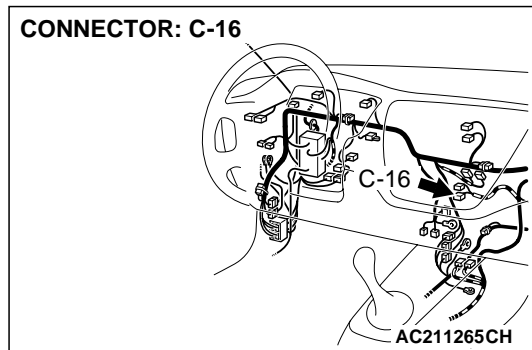
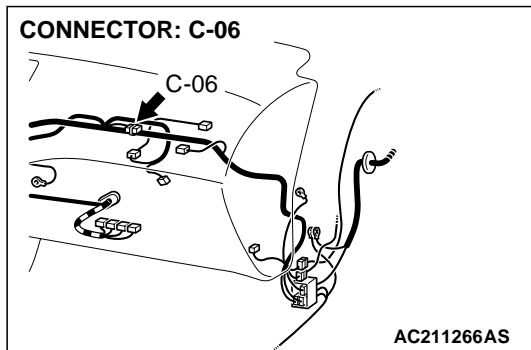
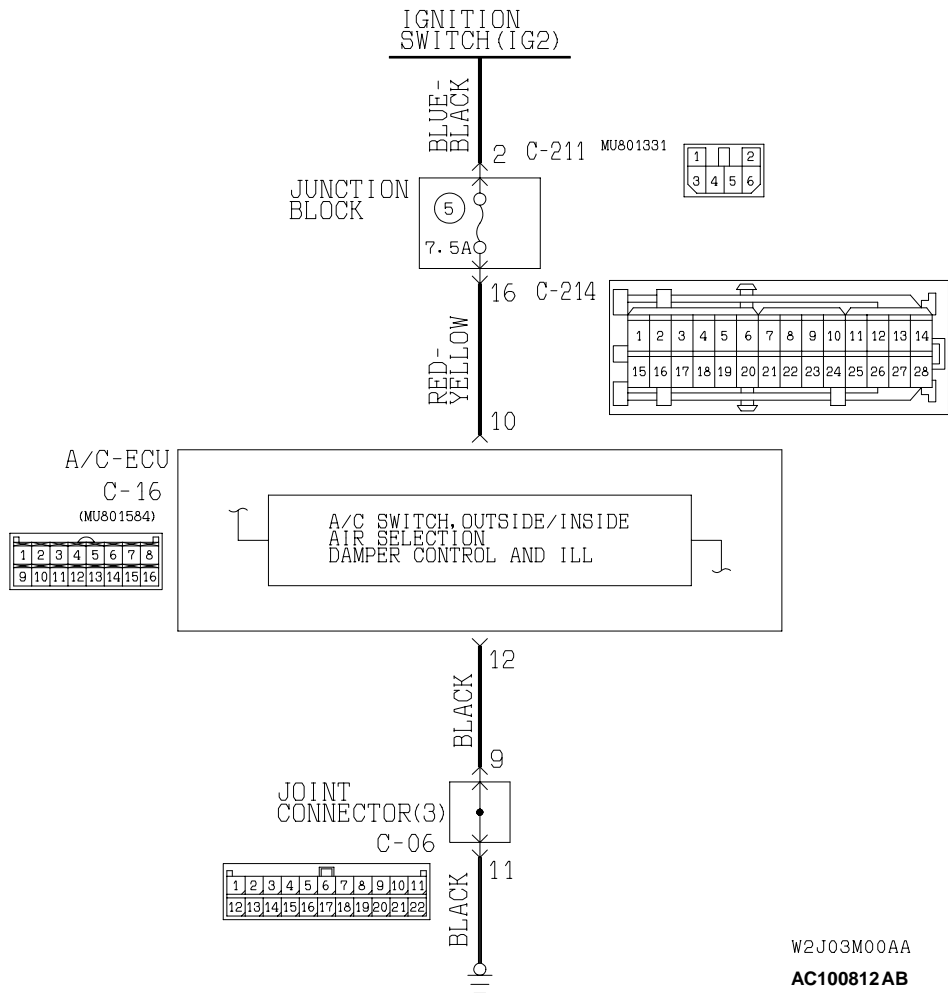

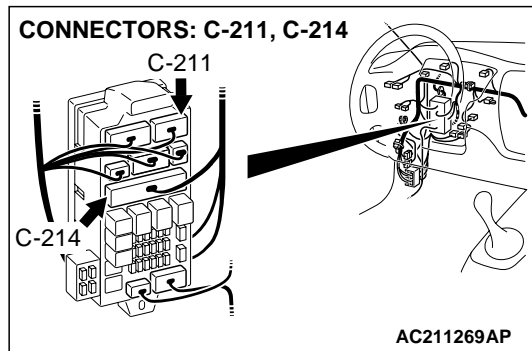
**TECHNICAL DESCRIPTION (COMMENT)**

The A/C-ECU power system may be defective if the air conditioner, defogger, and outside/inside air changeover damper motor all do not operate normally.

**TROUBLESHOOTING HINTS**

- Malformation of the A/C-ECU
- The wiring harness or connectors may have loose, corroded, or damaged terminals, or terminals pushed back in the connector

**DIAGNOSIS****Required Special Tools:**

- MB991223: Test Harness Set

**STEP 1. Measure the voltage at A/C-ECU connector C-16.**

- (1) Disconnect A/C-ECU connector C-16 and measure the voltage at the harness side.
- (2) Turn the ignition switch to the "ON" position.

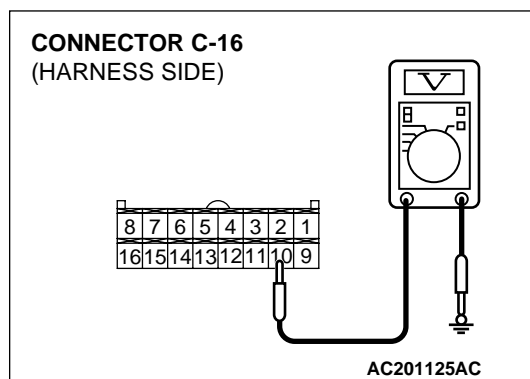
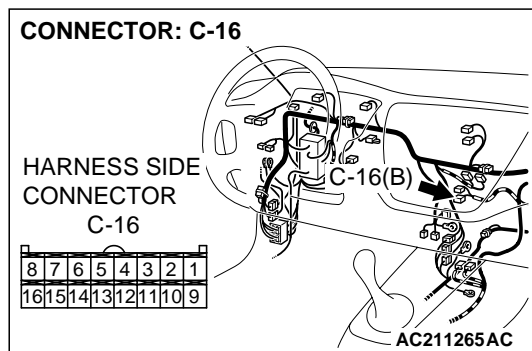

- (3) Measure the voltage between terminal 10 and ground.
  - The measured value should be approximately 12 volts (battery positive voltage).

**Q: Does the measured voltage correspond with this range?**

**YES :** Go to Step 4.

**NO :** Go to Step 2.

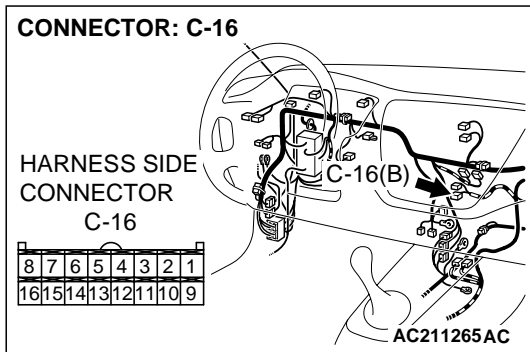

**STEP 2. Check A/C-ECU connector C-16 for loose, corroded or damaged terminals, or terminals pushed back in the connector.**

**Q: Is A/C-ECU connector C-16 in good condition?**

**YES :** Go to Step 3.

**NO :** Repair or replace the connector. Refer to GROUP 00E, Harness Connector Inspection [P.00E-2](#). Check that the air conditioning works normally.

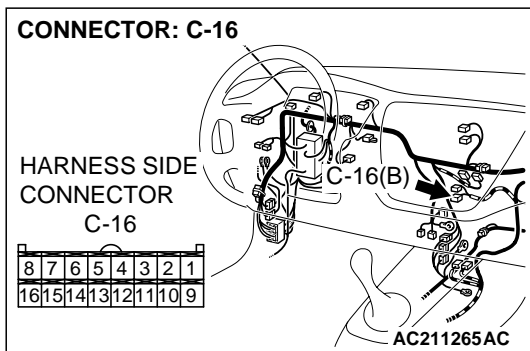

**STEP 3. Check the wiring harness between A/C-ECU connector C-16 (terminal 10) and the ignition switch (IG2).**

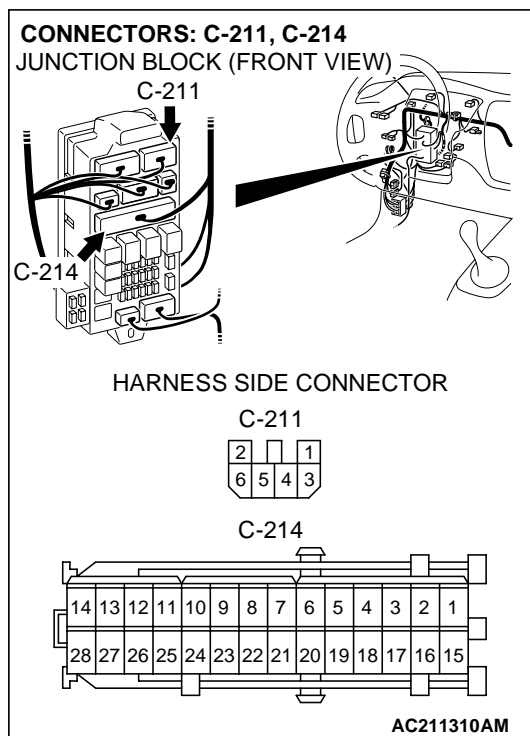

*NOTE: Also check junction block connectors C-214 and C-211 for loose, corroded, or damaged terminals, or terminals pushed back in the connector. If junction block connectors C-214 and C-211 is damaged, repair or replace the connector as described in GROUP 00E, Harness Connector Inspection [P.00E-2](#).*

**Q: Is the wiring harness between A/C-ECU connector C-16 (terminal 10) and the ignition switch (IG2) in good condition?**

**YES :** Check that the air conditioning works normally.

**NO :** Repair the wiring harness. Check that the air conditioning works normally.

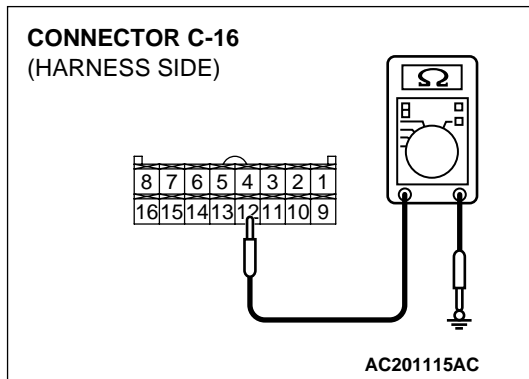
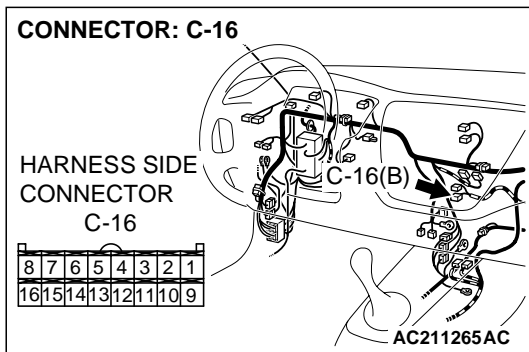

**STEP 4. Measure the resistance at A/C-ECU connector C-16.**

(1) Disconnect A/C-ECU connector C-16, and measure at the wiring harness side.

(2) Measure the resistance between terminal 12 and ground.

- The measured value should be 2 ohms or less.

**Q: Does the measured resistance value correspond with this range?**

**YES :** Replace the A/C-ECU, and check that the air conditioning works normally.

**NO :** Go to Step 5.

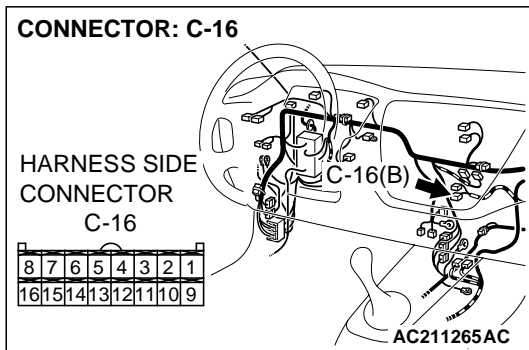

**STEP 5. Check A/C-ECU connector C-16 for loose, corroded or damaged terminals, or terminals pushed back in the connector.**

**Q: Is A/C-ECU connector in good condition?**

**YES :** Go to Step 6.

**NO :** Repair or replace the connector. Refer to GROUP 00E, Harness Connector Inspection [P.00E-2](#). Check that the air conditioning works normally.

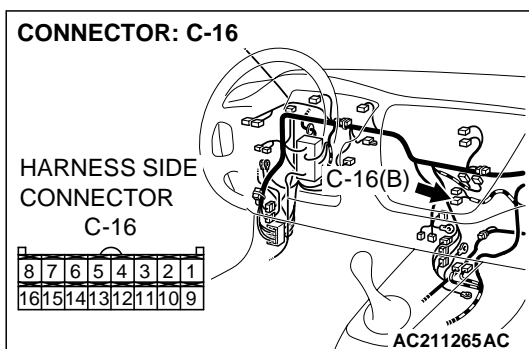

**STEP 6. Check the wiring harness between A/C-ECU connector C-16 (terminal 12) and the ground.**

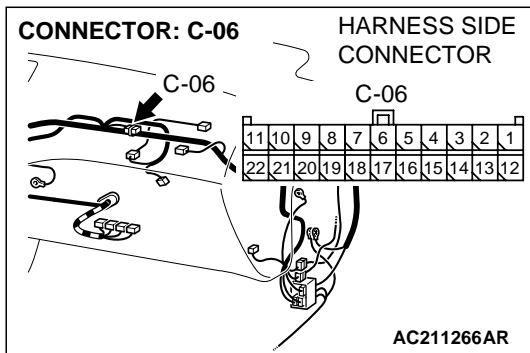

*NOTE: Also check joint connector (3) connectors C-06 for loose, corroded, or damaged terminals, or terminals pushed back in the connector. If joint connector (3) connectors C-06 is damaged, repair or replace the connector as described in GROUP 00E, Harness Connector Inspection P.00E-2.*

**Q: Is the wiring harness between A/C-ECU connector C-16 (terminal 12) and the ground in good condition?**

**YES :** Replace the A/C-ECU, and check that the air conditioning works normally.

**NO :** Repair the wiring harness. Check that the air conditioning works normally.

**CHECK AT ECU TERMINAL**

M1552010300420

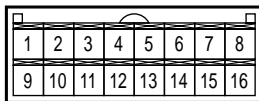

AC100607A

TERMINAL NO.	CHECK ITEM	CHECKING REQUIREMENT	NORMAL CONDITION
1	Rear defogger relay	Defogger switch: ON	0 V
		Defogger switch: OFF	Battery positive voltage
2	Inside/outside air changeover damper motor (outside air)	When the damper is moved to the inside air recirculation position	0 V
		When the damper is moved to the outside air inside air intake position	Battery positive voltage
3	Inside/outside air changeover damper motor (inside air)	When the damper is moved to the inside air recirculation position	Battery positive voltage
		When the damper is moved to the outside air inside air intake position	0 V
4	Output to the ECM (A/C1)	A/C stopped	0 V
		A/C switch: ON, blower switch: ON	Battery positive voltage
5	Output to the ECM (A/C2)	When the A/C is under low load	Battery positive voltage
		When the A/C is under high load	0 V
6	Power supply to the A/C illumination	Lighting switch: ON	Battery positive voltage
7	-	-	-
8	Blower switch (Io)	blower switch: Io	Battery positive voltage
9	-	-	-
10	Power supply to the ignition switch (IG2)	Ignition switch: ON	Battery positive voltage
11	Ground to the A/C illumination	Always	0 V
12	Ground	Always	0 V

TERMINAL NO.	CHECK ITEM	CHECKING REQUIREMENT	NORMAL CONDITION
13	Air thermo sensor (outlet side)	Sensor probe temperature 25°C (1.5k ohm)	2.2 V
14	Air thermo sensor (inlet side)	Sensor probe temperature 25°C (1.5k ohm)	2.2 V
15	-	-	-
16	Ground to the air thermo sensor	Always	0 V

## SPECIAL TOOLS

M1552000600282

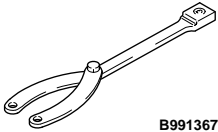
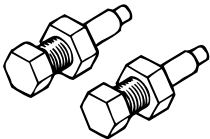
TOOL	TOOL NUMBER AND NAME	REPLACED BY MILLER TOOL NUMBER	APPLICATION
	MB991367 Special spanner	MB991367-01	Armature mounting nut of compressor removal and installation
	MB991386 Pin	MIT217213	Armature mounting nut of compressor removal and installation

## ON-VEHICLE SERVICE

### REFRIGERANT LEVEL TEST

M1552008400312

Use the refrigerant recovery station to remove all of the refrigerant, and then calculate the amount of the refrigerant and charge it.

### A/C COMPRESSOR CLUTCH TEST

M1552019900010

1. Disconnect the A/C compressor clutch connector.
2. Connect positive battery voltage directly to the connector for the A/C compressor clutch.
3. If the A/C compressor clutch is normal, there will be "click." If the pullet and armature do not make contact ("click"), there is a malfunction.

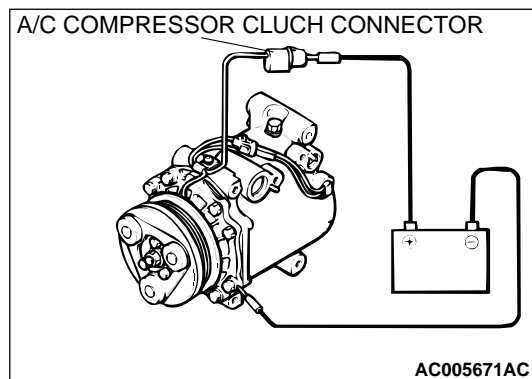

### RECEIVER DRIER TEST

M1552008600242

Operate the unit and check the piping temperature by touching the receiver drier outlet and inlet.

If there is a difference in the temperatures, the receiver drier is restricted.

Replace the receiver drier.

### PRESSURE SWITCH CHECK

M1552010400308

1. Remove the dual pressure switch connector and connect the high/low pressure side terminals located on the harness side as shown in the illustration.
2. Install a gauge manifold to the high-pressure side service valve of the refrigerant line. (Refer to P.55-94.)
3. When the high/low pressure sides of the dual pressure switch are at operation pressure (ON) the resistance should be less than two ohms between the terminals. If open circuit, replace the switch.

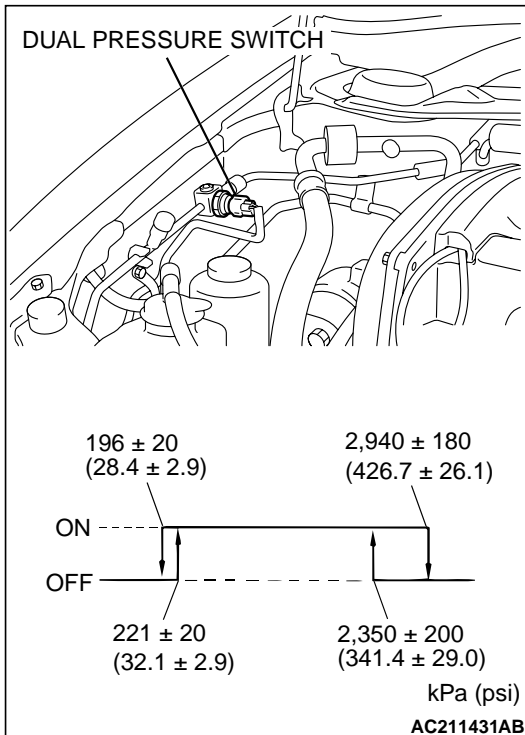

ITEM	SWITCH POSITION	
	OFF to ON	ON to OFF
Low-pressure side kPa (psi)	221 ± 20 (32.1 ± 2.9)	196 ± 20 (28.4 ± 2.9)
High-pressure side kPa (psi)	2,350 ± 200 (341.4 ± 29.0)	2,940 ± 180 (426.7 ± 26.1)

### COMPRESSOR DRIVE BELT ADJUSTMENT

M1552001000283

Refer to GROUP 00, Maintenance Service – Drive Belts P.00-37.

### CHARGING

M1552001200317

Use the refrigerant recovery station to charge the refrigerant.

### METHOD BY USING REFRIGERANT RECOVERY AND RECYCLING UNIT

Using the refrigerant recovery and recycling unit, refill the refrigerant.

*NOTE: Refer to that Refrigerant Recovery and Recycling Unit Instruction Manual for operation of the unit.*

### DISCHARGING SYSTEM

Use the refrigerant recovery unit to discharge refrigerant gas from the system.

*NOTE: Refer to that Refrigerant Recovery and Recycling Unit Instruction Manual for operation of the unit.*

**REFILLING OF OIL IN THE A/C SYSTEM**

Too little oil will provide inadequate compressor lubrication and cause a compressor failure. Too much oil will increase discharge air temperature.

When a compressor is installed at the factory, it contains 140 cm<sup>3</sup> (4.7 fl oz) of refrigerant oil. While the A/C system is in operation, the oil is carried through the entire system by the refrigerant. Some of this oil will be trapped and retained in various parts of the system.

When the following system components are changed, it is necessary to add oil to the system to replace the oil being removed with the component.

**Compressor oil: SUN PAG 56****Quantity:**

- **Evaporator: 60 cm<sup>3</sup> (2.0 fl oz)**
- **Condenser: 15 cm<sup>3</sup> (0.5 fl oz)**
- **Suction hose: 10 cm<sup>3</sup> (0.3 fl oz)**

**PERFORMANCE TEST**

M1552001400300

1. The vehicles to be tested should be in a place that is not in direct sunlight.
2. Close the high and low-pressure valve of the gauge manifold.
3. Connect the charging hose (blue) to the low-pressure valve and connect the charging hose (red) to the high-pressure valve of the gauge manifold.
4. Install the quick joint (for low-pressure) to the charging hose (blue), and connect the quick joint (for high-pressure) to the charging hose (red).

**CAUTION**

- **To connect the quick joint, press section A firmly against the service valve until a click is heard.**
- **When connecting, run your hand along the hose while pressing to ensure that there are no bends in the hose.**

*NOTE: The high-pressure service valve is on the liquid pipe A and the low-pressure service valve is on the suction hose.*

5. Connect the quick joint (for low-pressure) to the low-pressure service valve and connect the quick joint (for high-pressure) to the high-pressure service valve.
6. Start the engine.
7. Set the A/C controls as follows:
  - A/C switch: A/C – ON position
  - Mode selection: FACE position
  - Temperature control: MAXIMUM COOLING position
  - Air selection: RECIRCULATION position
  - Blower switch: "4" (HI) position
8. Adjust engine speed to idle speed with A/C clutch engaged.
9. Engine should be warmed up with doors and windows open.

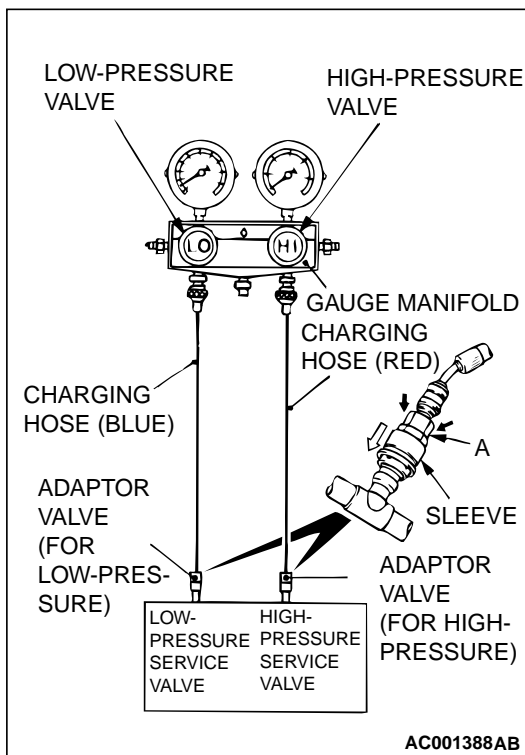



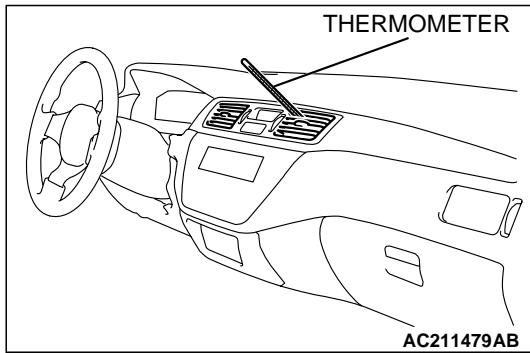

10. Insert a thermometer in the center air outlet and operate the engine for 20 minutes.

*NOTE: If the clutch cycles, take the reading before the clutch disengages.*

11. Note the discharge air temperature.

### Performance Temperature Chart

GARAGE AMBIENT TEMPERATURE °C (°F)	20 (68)	25 (77)	30 (86)	35 (95)
Discharge air temperature °C (°F)	8.0 – 11.0 (46 – 52)	12.0 – 16.0 (54 – 61)	17.0 – 21.0 (63 – 70)	22.5 – 27.5 (73 – 82)
Compressor high pressure kPa (psi)	740 – 840 (107 – 122)	950 – 1,050 (138 – 152)	1,160 – 1,300 (168 – 189)	1,360 – 1,550 (197 – 225)
Compressor low pressure kPa (psi)	150 – 190 (21.8 – 27.6)	190 – 240 (27.6 – 34.8)	240 – 300 (34.8 – 43.5)	300 – 375 (43.5 – 54.4)

### REFRIGERANT LEAK REPAIR PROCEDURE

M1552001500244

#### LOST CHARGE

If the system has lost all charge due to a leak:

1. Evacuate the system. (Refer to P.55-71.)
2. Charge the system with approximately 0.453 kg (1 pound) of refrigerant.
3. Check for leaks.
4. Discharge the system.
5. Repair leaks.

#### **CAUTION**

**Replacement filter-drier units must be sealed while in storage. The drier used in these units will saturate water quickly upon exposure to the atmosphere. When installing a drier, have all tools and supplies ready for quick assembly to avoid keeping the system open any longer than necessary.**

6. Replace receiver drier.
7. Evacuate and charge system.

#### LOW CHARGE

If the system has not lost all of its refrigerant charge; locate and repair all leaks. If it is necessary to increase the system pressure to find the leak (because of an especially low charge) add refrigerant. If it is possible to repair the leak without discharging the refrigerant system, use the procedure for correcting low refrigerant level.

#### HANDLING TUBING AND FITTINGS

Kinks in the refrigerant tubing or sharp bends in the refrigerant hose lines will greatly reduce the capacity of the entire system. High pressures are produced in the system when it is operating. Extreme care must be exercised to make sure that all connections are pressure tight. Dirt and moisture can enter the system when it is opened for repair or replacement of lines or components. The following precautions must be observed. The system must be completely discharged before opening any fitting of connection in the refrigeration system. Open fittings with caution even after the system has been discharged. If any pressure is noticed as a fitting is loosened, allow trapped pressure to bleed off very slowly.

Never attempt to rebend formed lines to fit. Use the correct line for the installation you are servicing. A good rule for the flexible hose lines is keep the radius of all bends at least 10 times the diameter of the hose.

Sharper bends will reduce the flow of refrigerant. The flexible hose lines should be routed so that they are at least 80 mm (3.1 inches) from the exhaust manifold. It is good practice to inspect all flexible hose lines at least once a year to make sure they are in good condition and properly routed.

On standard plumbing fittings with O-rings, these O-rings are not reusable.

**COMPRESSOR NOISE CHECK**

M1552008700238

You must first know the conditions when the noise occurs. These conditions are: weather, vehicle speed, in gear or neutral, engine temperature or any other special conditions.

Noises that develop during A/C operation can often be misleading. For example: what sounds like a failed front bearing or connecting rod, may be caused by loose bolts, nuts, mounting brackets, or a loose clutch assembly. Verify accessory drive belt tension (power steering or generator).

Improper accessory drive belt tension can cause a misleading noise when the compressor is engaged and little or no noise when the compressor is disengaged.

Drive belts are speed-sensitive. That is, at different engine speeds, and depending upon belt tension, belts can develop unusual noises that are often mistaken for mechanical problems within the compressor.

**ADJUSTMENT**

1. Select a quiet area for testing. Duplicate conditions as much as possible. Switch compressor on and off several times to clearly identify compressor noise. To duplicate high ambient conditions (high head pressure), restrict air flow through condenser. Install manifold gauge set to make sure discharge pressure doesn't exceed 2,070 kPa (300.2 psi).
2. Tighten all compressor mounting bolts, clutch mounting bolt, and compressor drive belt. Check to assure clutch coil is tight (no rotation or wobble).
3. Check refrigerant hoses for rubbing or interference that can cause unusual noises.
4. Check refrigerant charge. (Refer to [P.55-71.](#))
5. Recheck compressor noise as in Step 1.
6. If noise still exists, loosen compressor mounting bolts and retighten. Repeat Step 1.
7. If noise continues, replace compressor and repeat Step 1.

**POWER RELAY CHECK**

M1552008800268

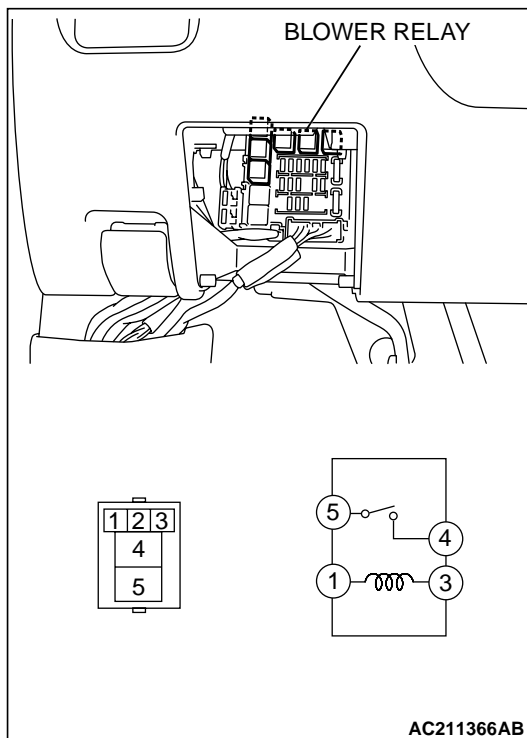
**BLOWER RELAY CONTINUITY CHECK**

BATTERY VOLTAGE	TESTER CONNECTION	SPECIFIED CONDITION
Not applied	4 – 5	Open circuit
<ul style="list-style-type: none"> <li>• Connect terminal 1 to the positive battery terminal</li> <li>• Connect terminal 3 to the negative battery terminal</li> </ul>	4 – 5	Less than 2 ohms

**A/C COMPRESSOR RELAY, CONDENSER FAN RELAY (LO) and (HI) CONTINUITY CHECK**

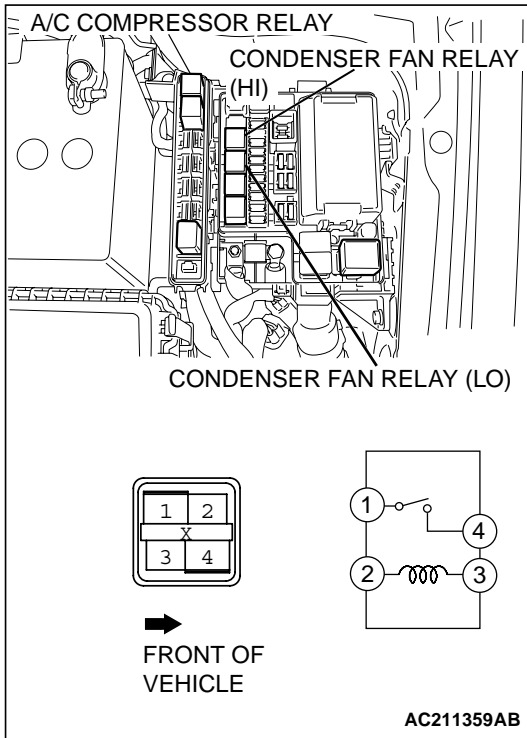

BATTERY VOLTAGE	TESTER CONNECTION	SPECIFIED CONDITION
Not applied	1 – 4	Open circuit
<ul style="list-style-type: none"> <li>Connect terminal 2 to the positive battery terminal</li> <li>Connect terminal 3 to the negative battery terminal</li> </ul>	1 – 4	Less than 2 ohms

**IDLE-UP OPERATION CHECK**

M1552001600304

- Before inspection and adjustment, set vehicle in the following condition:
  - Engine coolant temperature: 80 – 90 °C (176.0 - 194.0 °F)
  - Lights, electric cooling fan and accessories: Set to OFF
  - Transmission: Neutral
  - Steering wheel: Straightforward
- Check whether or not the idle speed is the standard value. Refer to GROUP 13A, On-vehicle Service – Basic Idle Speed Adjustment [P.13A-760](#).
 

**Standard value: 850 ± 50 r/min**
- When the A/C is running after turning the A/C switch to ON, and the blower switch to the 3(MH) or 4(HI) position, check to be sure that the idle speed is at the standard value.
 

**Standard value: 850 ± 50 r/min**

*NOTE: The engine control module determines whether the A/C load is low or high according to the output signal from the automatic compressor controller.*

*NOTE: It is not necessary to make an adjustment, because the idling speed is automatically adjusted by the ISC system. If, however, a deviation from the standard value occurs for some reason, check the ISC system.*

*NOTE: Check 4 minutes after idling begins.*

**HEATER CONTROL ASSEMBLY AND A/C SWITCH****REMOVAL AND INSTALLATION**

M1552002400284

**Pre-removal and Post-installation Operation**

- Under Cover Removal and Installation (Refer to GROUP 52A, Instrument Panel P.52A-3.)
- Foot Duct (LH) Removal and Installation (Refer to P.55-95.)

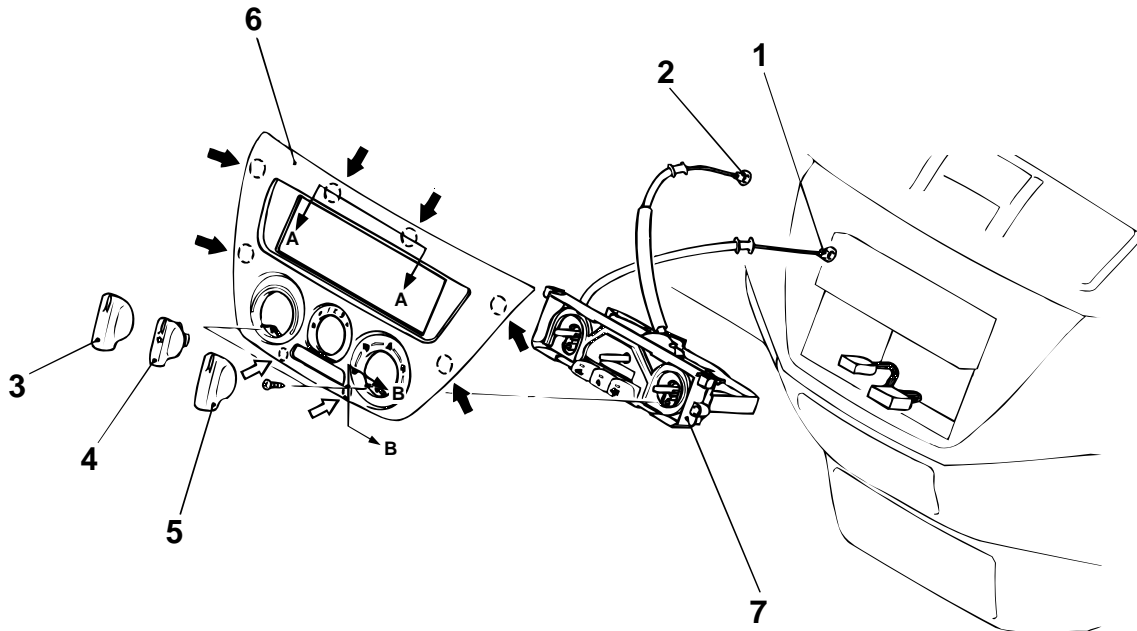
**NOTE**

- (1) ➔ CLIP LOCATION  
(2) ⇨ CLAW LOCATION

AC203835AB

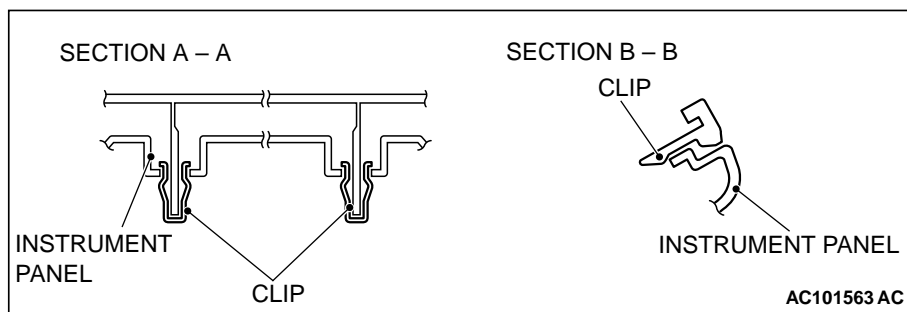

AC101563 AC

**REMOVAL STEPS**

- >>B<< 1. AIR MIX DOOR CABLE CONNECTION
- >>A<< 2. BLOW VENT CHANGEOVER DAMPER CABLE CONNECTION
3. TEMPERATURE ADJUSTMENT KNOB
4. AIR VOLUME ADJUSTMENT KNOB
5. BLOW VENT SWITCHING KNOB

**REMOVAL STEPS (Continued)**

6. CENTER PANEL
- RADIO AND TAPE PLAYER (REFER TO GROUP 54A- AUDIO SYSTEM - RADIO AND TAPE PLAYER, CD PLAYER AND CD AUTO CHANGER P.54A-146.)
7. HEATER CONTROL PANEL ASSEMBLY

**INSTALLATION SERVICE POINTS**

**>>A<< BLOW VENT CHANGEOVER DAMPER CABLE CONNECTION**

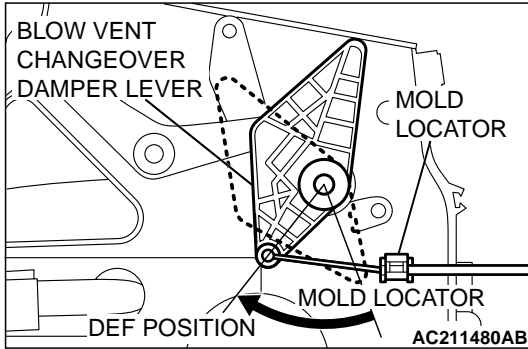

1. Set the heater control assembly's blow vent changeover knob to the DEF position.
2. Set the heater unit's blow vent changeover damper lever to the DEF position (turn the damper relay to the left until it stops) and install the cable.
3. Set the mold locator to the heater unit case and secure with a clip.

**>>B<< AIR MIX DOOR CABLE CONNECTION**

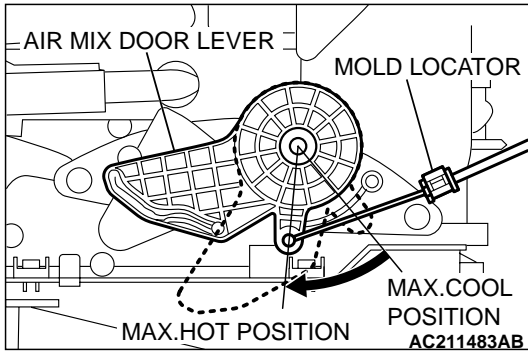

1. Turn the heater control assembly's temperature adjustment knob all the way to the HOT side.
2. Set the heater unit's air mix door lever to the MAX HOT position (turn the damper lever as the left illustration) and attach the cable.
3. Set the mold locator to the heater unit case and secure with a clip.

**INSPECTION**

M1551006300231

**Blower Switch Continuity Check**

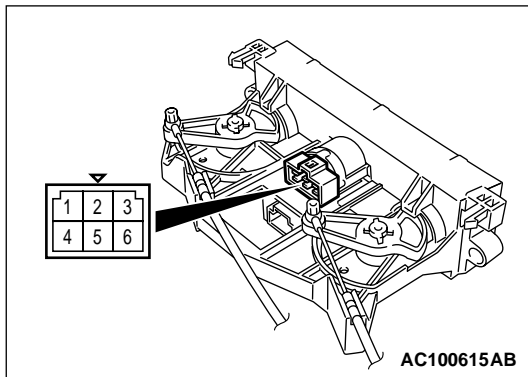

SWITCH POSITION	TESTER CONNECTION	SPECIFIED CONDITION
0 (OFF)	1 - 2, 2 - 4, 2 - 5, 2 - 6	Open circuit
1 (LO)	1 - 2	Less than 2 ohms
2 (ML)	2 - 4	Less than 2 ohms
3 (MH)	2 - 5	Less than 2 ohms
4 (HI)	2 - 6	Less than 2 ohms

HEATER CONTROL ASSEMBLY DISASSEMBLY AND ASSEMBLY

M1552014200124

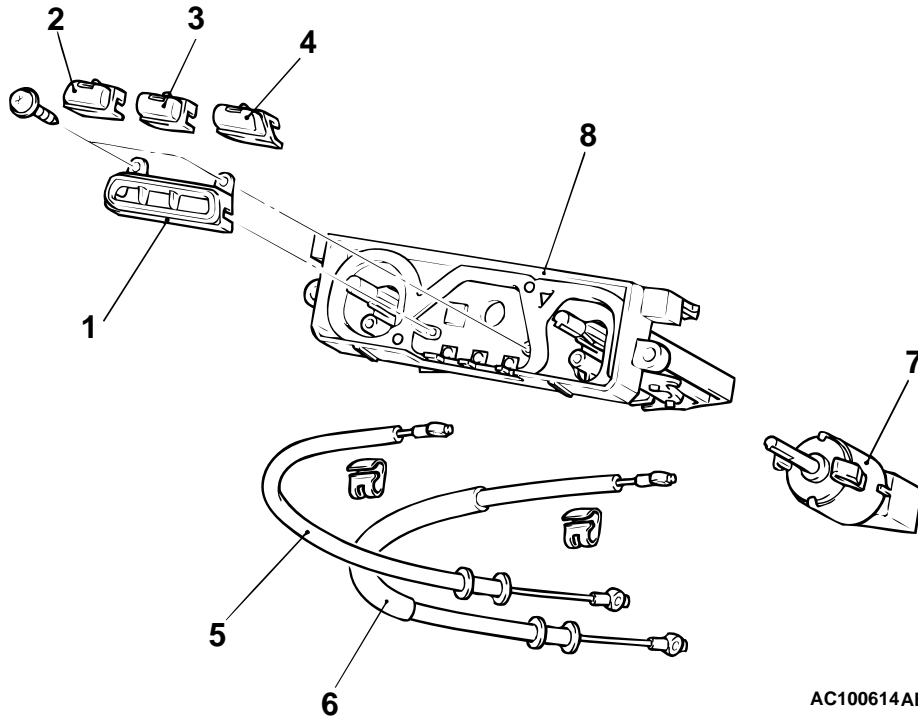

AC100614AB

**DISASSEMBLY STEPS**

- 1. SWITCH PANEL
- 2. REAR WINDOW DEFOGGER SWITCH
- 3. AIR CONDITIONER SWITCH
- 4. INSIDE/OUTSIDE AIR CHANGEOVER SWITCH
- <<A>> 5. AIR MIX DOOR CABLE

**DISASSEMBLY STEPS**

- <<A>> 6. BLOW VENT CHANGEOVER DAMPER CABLE
- 7. BLOWER SWITCH ASSEMBLY
- 8. HEATER CONTROL PANEL (A/C-ECU)

**DISASSEMBLY SERVICE POINT**

**<<A>> BLOW VENT CHANGEOVER DAMPER CABLE AND AIR MIX DOOR CABLE REMOVAL**

Insert a flat-tipped screwdriver into the clip through the inside of the control base and prize out the clip claw to disconnect the cables.

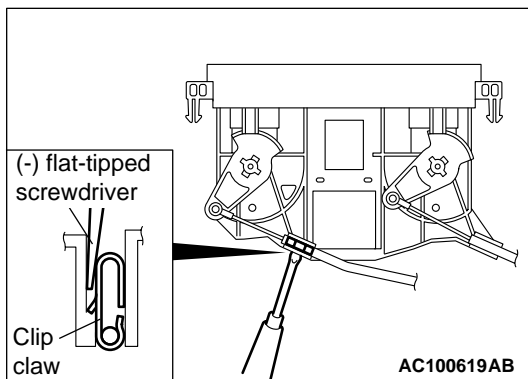

AC100619AB

# HEATER UNIT, HEATER CORE, BLOWER ASSEMBLY AND EVAPORATOR UNIT

## REMOVAL AND INSTALLATION

M1552011600231

**⚠ WARNING**

*When removing and installing the heater unit, do not let it bump against the SRS-ECU or the components.*

**Pre-removal and Post-installation Operation**

- Refrigerant draining and Refilling (Refer to P.55-71.)
- Engine coolant Draining and Refilling (Refer to GROUP 00, Engine Coolant P.00-44.)
- Instrument Panel Assembly Removal and Installation (Refer to GROUP 52A, Instrument Panel Assembly P.52A-3.)
- Steering Column Shaft Assembly Removal and Installation (Refer to GROUP 37, Steering Shaft Assembly P.52A-3.)
- Front Seat Removal and Installation (Refer to GROUP 52A, Front Seat Assembly P.52A-20.)
- Front Floor Console Assembly Removal and Installation (Refer to GROUP 52A, Front Floor Console P.52A-7.)
- Floor Carpet Removal and Installation

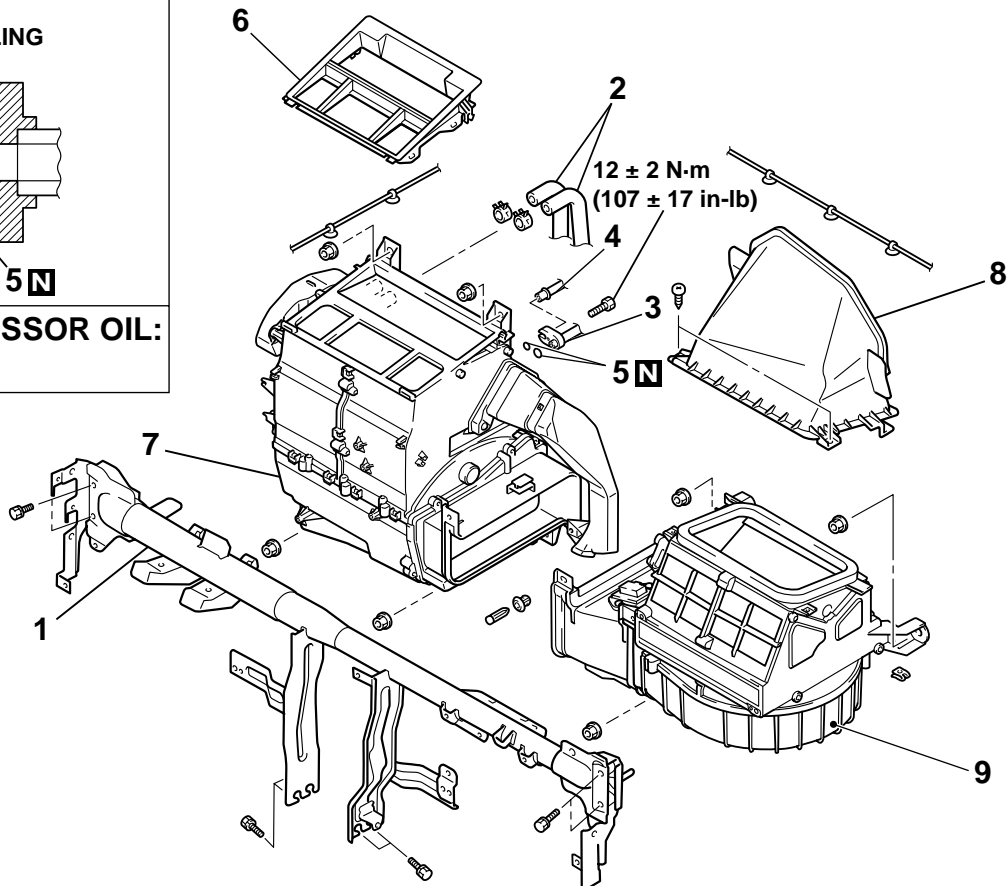
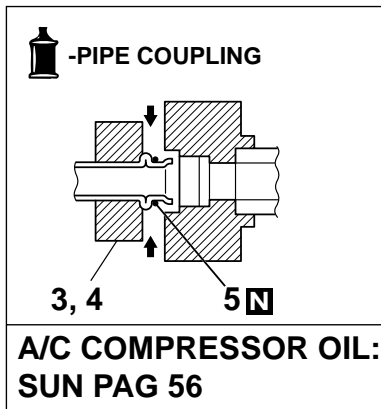

AC211505AB

**REMOVAL STEPS**

1. FRONT DECK CROSSMEMBER <<A>>
2. HEATER HOSE CONNECTION <<A>>

**REMOVAL STEPS (Continued)**

3. FLEXIBLE SUCTION HOSE CONNECTION
4. LIQUID PIPE B CONNECTION

**TSB Revision**

**REMOVAL STEPS (Continued)**

5. O-RING
6. CENTER DUCT
7. HEATER UNIT
8. INTAKE DUCT
9. BLOWER ASSEMBLY

**REMOVAL SERVICE POINT****<<A>> FLEXIBLE SUCTION HOSE AND LIQUID PIPE B DIS-CONNECTION****⚠ CAUTION**

As the compressor oil and receiver are highly moisture absorbent, use a non-porous material to hose and nipples. To prevent the entry of dust or other foreign bodies, plug the dismantled hose and the nipples of the expansion valves.

**HEATER UNIT DISASSEMBLY AND ASSEMBLY**

M1551005400161

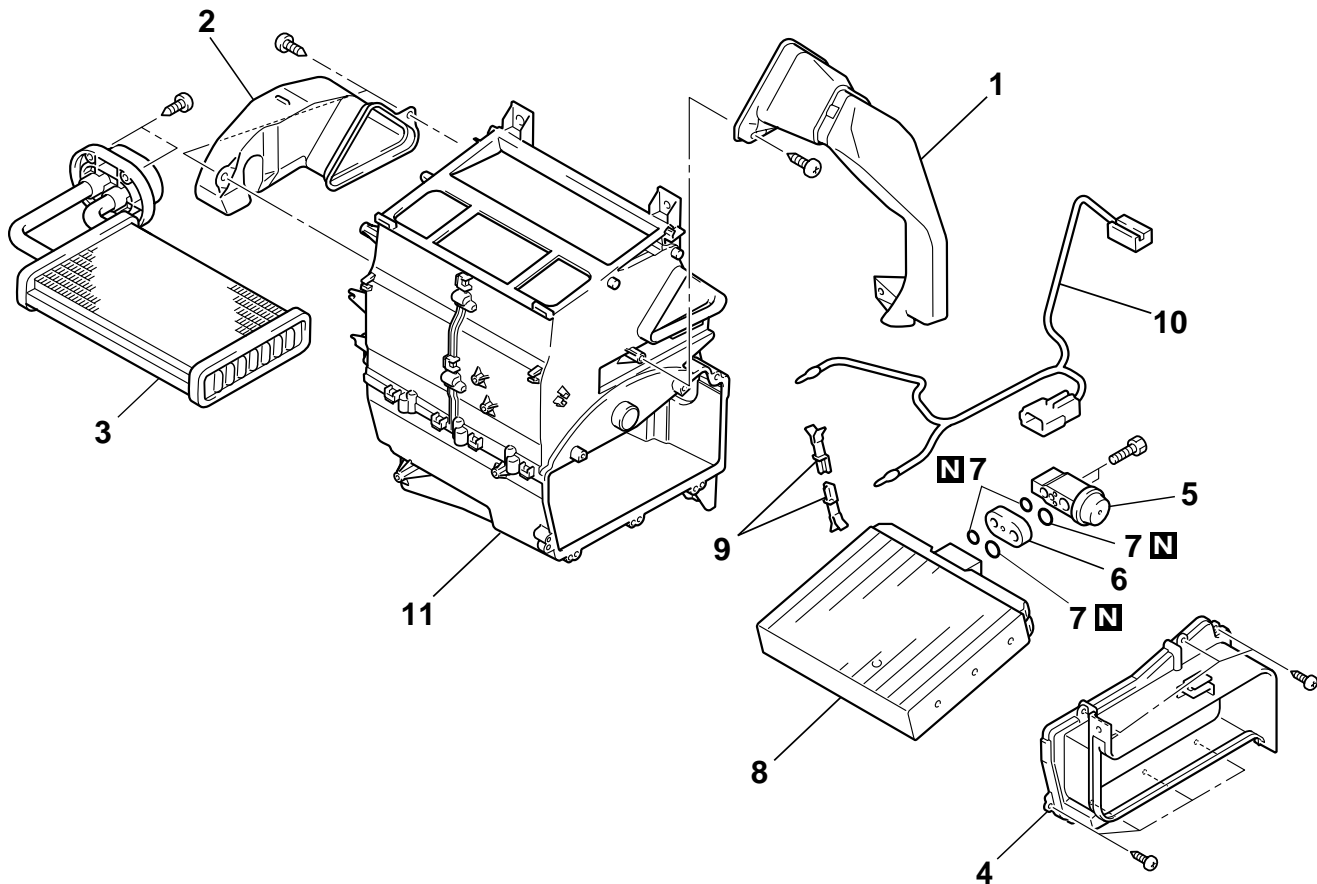

AC211527 AB

**DISASSEMBLY STEPS**

1. RIGHT-HAND FOOT DUCT
2. LEFT-HAND FOOT DUCT
3. HEATER CORE
4. EVAPORATOR COVER
5. EXPANSION VALVE
6. JOINT

**DISASSEMBLY STEPS (Continued)**

7. O-RING
8. EVAPORATOR
9. AIR THERMO SENSOR CLIP
10. AIR THERMO SENSOR
11. HEATER CASE



**BLOWER ASSEMBLY DISASSEMBLY AND ASSEMBLY**

M1551005500146

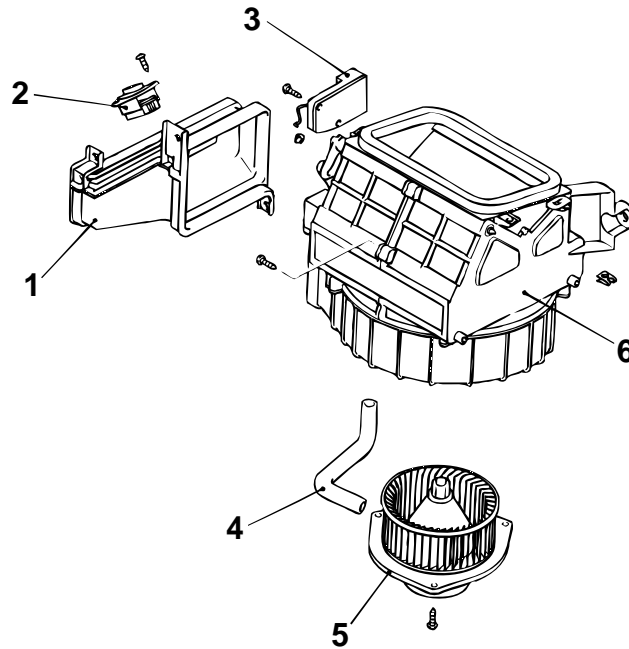

AC100622AB

**DISASSEMBLY STEPS**

1. JOINT DUCT
2. RESISTOR
3. OUTSIDE/INSIDE AIR SELECTION  
DAMPER CONTROL MOTOR

**DISASSEMBLY STEPS (Continued)**

4. HOSE
5. BLOWER MOTOR
6. BLOWER CASE

**BLOWER ASSEMBLY AND RESISTOR****REMOVAL AND INSTALLATION**

M1551002800289

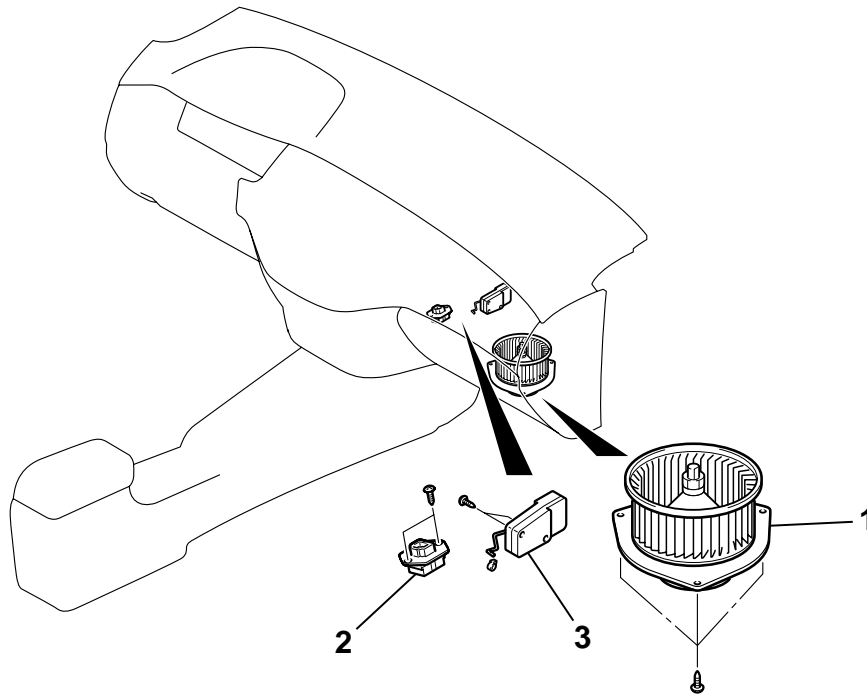

AC211053AB

&lt;&lt;A&gt;&gt;

**BLOWER MOTOR REMOVAL STEPS**

1. BLOWER MOTOR
- RESISTOR REMOVAL STEPS**
- GLOVE BOX (OUTER AND INNER) (REFER TO GROUP 52A, INSTRUMENT PANEL [P.52A-3.](#))
  - ECM
2. RESISTOR

**OUTSIDE/INSIDE AIR SELECTION DAMPER CONTROL MOTOR REMOVAL STEPS**

- GLOVE BOX (OUTER AND INNER) (REFER TO GROUP 52A, INSTRUMENT PANEL [P.52A-3.](#))
  - ECM
3. OUTSIDE/INSIDE AIR SELECTION DAMPER CONTROL MOTOR

**REMOVAL SERVICE POINT**<<A>> **BLOWER MOTOR REMOVAL**

*NOTE: A normal plate-type ratchet driver is recommended.*

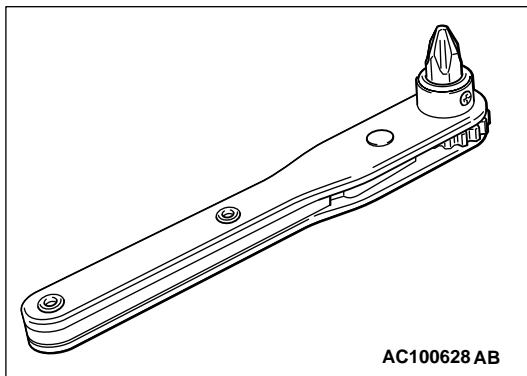

AC100628 AB

M1551006300242

## INSPECTION

### RESISTOR CHECK

Use an ohmmeter to measure the resistance between the terminals. Check that the measured value is at the standard value.

**Standard value:**

MEASUREMENT TERMINAL	STANDARD VALUE $\Omega$
Between terminals 2 and 4 (LO)	2.54
Between terminals 1 and 2 (ML)	1.24
Between terminals 2 and 3 (MH)	0.6

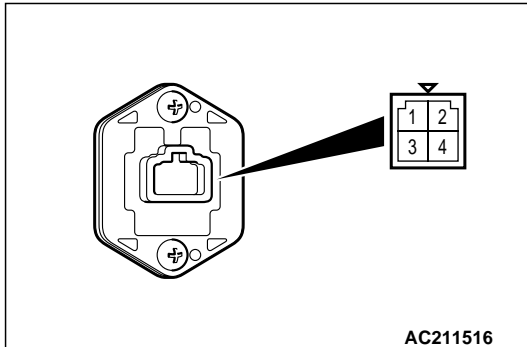

### BLOWER FAN AND MOTOR CHECK

When battery voltage is applied between the terminals, check that the motor operates. Also, check that there is no abnormal noise.

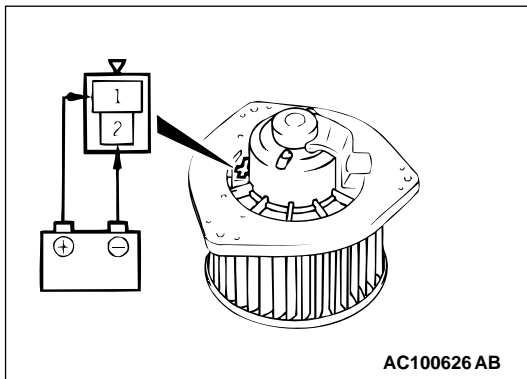

**OUTSIDE/INSIDE AIR SELECTION DAMPER  
CONTROL MOTOR CHECK**

**⚠ CAUTION**

Cut off the battery voltage when the damper is in the inside or outside air position.

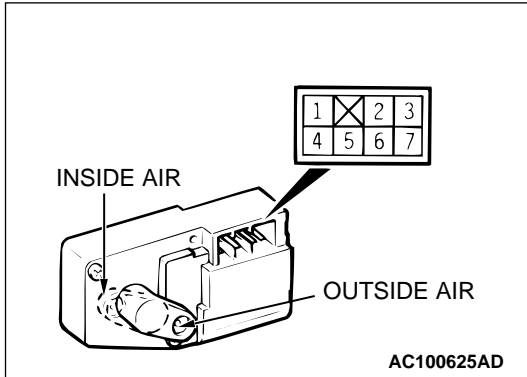

LEVER POSITION	BATTERY CONNECTION	LEVER OPERATION
At the inside position	<ul style="list-style-type: none"> <li>• Connect terminal 7 to the positive battery terminal</li> <li>• Connect terminal 6 to the negative battery terminal</li> </ul>	The lever moves from the inside position to the outside position
At the outside position	<ul style="list-style-type: none"> <li>• Connect terminal 7 to the positive battery terminal</li> <li>• Connect terminal 4 to the negative battery terminal</li> </ul>	The lever moves from the outside position to the inside position

# EVAPORATOR ASSEMBLY

## REMOVAL AND INSTALLATION

M1552003600162

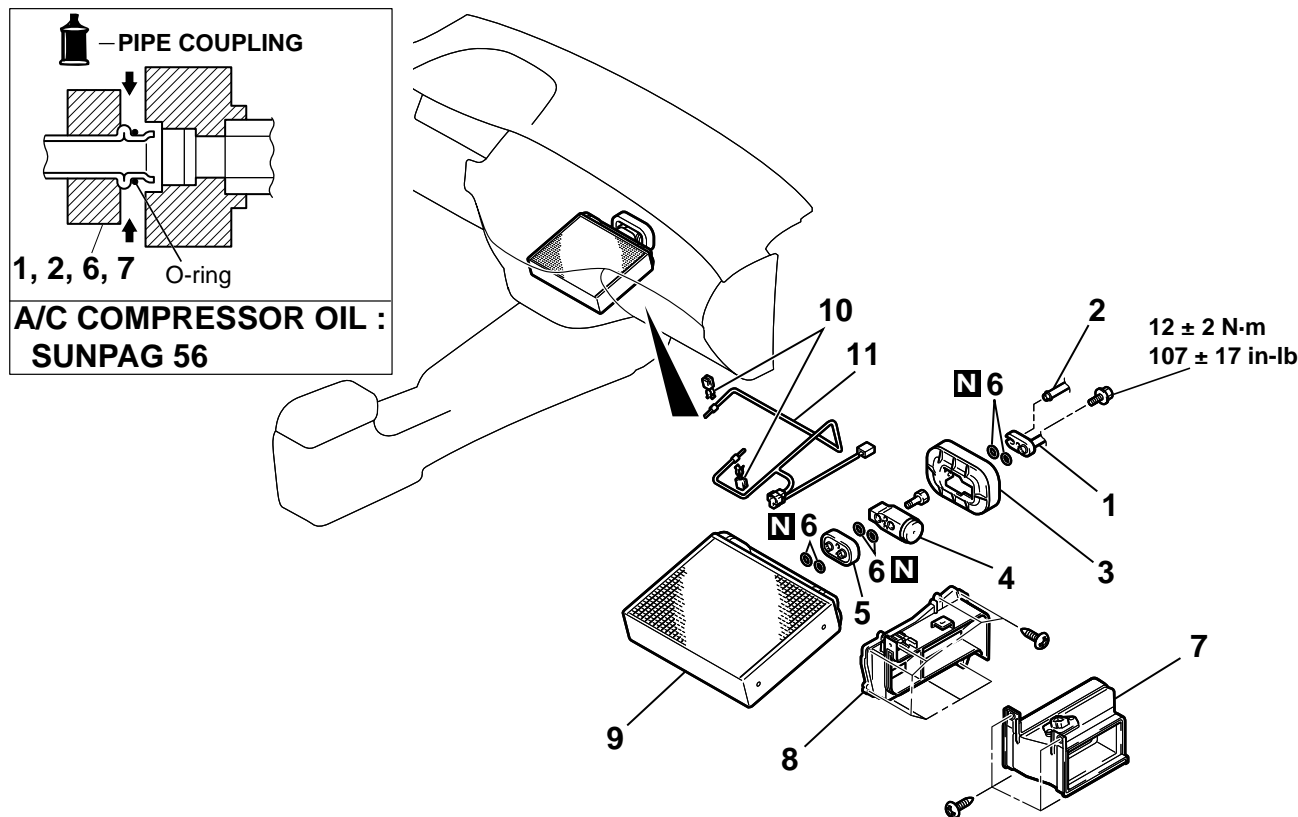

AC211054AB

### REMOVAL STEPS

- REFRIGERANT DRAINING AND REFILLING (REFER TO P.55-71.)
  - GLOVE BOX (REFER TO GROUP 52A, INSTRUMENT PANEL P.52A-3.)
  - ECM
1. FLEXIBLE SUCTION HOSE CONNECTION
  2. LIQUID PIPE B CONNECTION

### REMOVAL STEPS (Continued)

3. EXPANSION VALVE COVER
4. EXPANSION VALVE
5. JOINT
6. O-RING
7. JOINT DUCT
8. EVAPORATOR COVER
9. EVAPORATOR
10. AIR THERMO SENSOR CLIP
11. AIR THERMO SENSOR

<<A>>

<<B>> >>A<<

<<A>>

### REMOVAL SERVICE POINT

<<A>> FLEXIBLE SUCTION HOSE, LIQUID PIPE B DIS-CONNECTION

#### **CAUTION**

As the compressor oil and receiver are highly moisture absorbent, use a non-porous material to hose and nipples. To prevent the entry of dust or other foreign bodies, plug the dismantled hose and the nipples of the expansion valves.

## &lt;&lt;B&gt;&gt; EVAPORATOR REMOVAL

**⚠ CAUTION****Do not cut the upper side of the pad.**

1. When removing the evaporator, cut and fold back the dashboard pad as in the diagram. (The thickness of the pad interferes with the removal of the evaporator.)
2. Remove the evaporator.

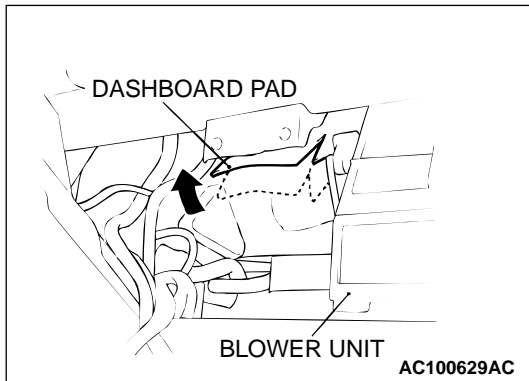

## INSTALLATION SERVICE POINTS

## &gt;&gt;A&lt;&lt; EVAPORATOR INSTALLATION

After installing the evaporator, glue the cut dashboard panel pad with an adhesive agent.

## INSPECTION

M1552014300552

## AIR THERMO SENSOR INSPECTION

## INLET SIDE

Measure the resistance between connector terminals 1 and 3 under at least two different temperatures. The resistance values should generally match those in the graph.

*NOTE: The temperature at the check should not exceed the range in the graph.*

## OUTLET SIDE

Measure the resistance between connector terminals 4 and 5 under at least two different temperatures. The resistance values should generally match those in the graph.

*NOTE: The temperature at the check should not exceed the range in the graph.*

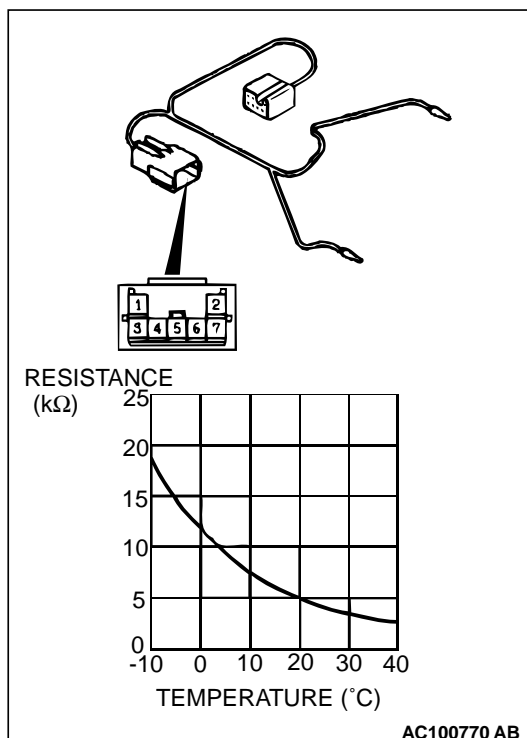

# COMPRESSOR ASSEMBLY AND TENSION PULLEY

## REMOVAL AND INSTALLATION

M1552004100201

### Pre-removal Operation

- Refrigerant Discharging (Refer to P.55-71.)

### Post-installation Operation

- Drive Belt Tension Adjustment (Refer to GROUP 00E, Maintenance Service – Drive Belt P.00-37.)
- Refrigerant Charging (Refer to P.55-71.)

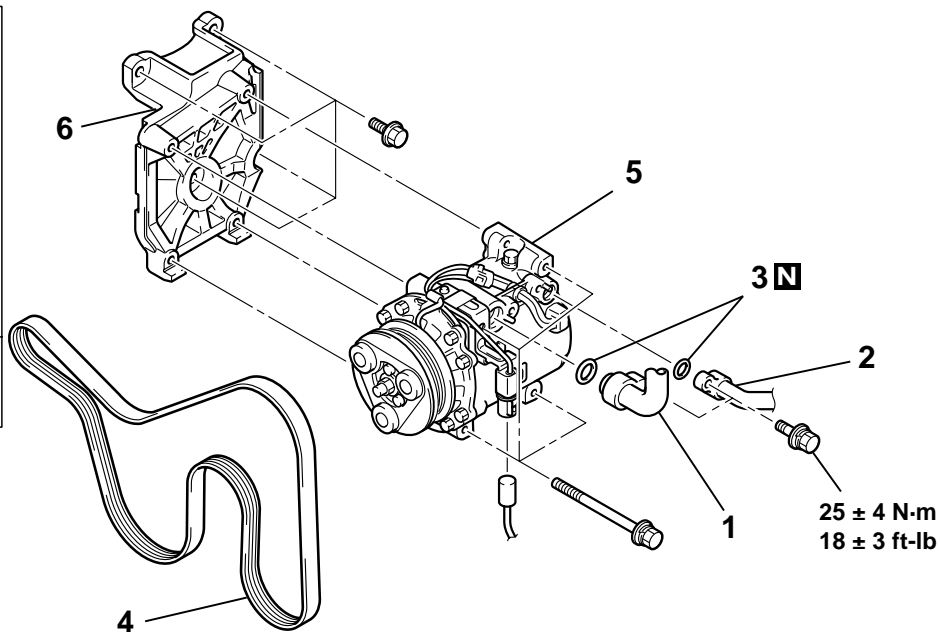
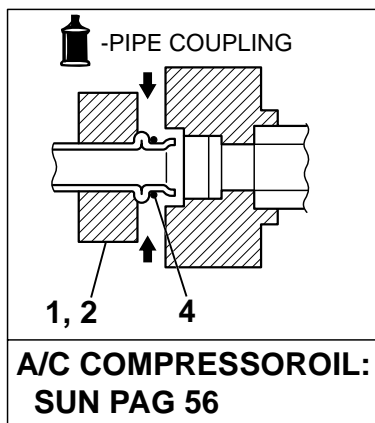

AC210883AB

<<A>>

- REMOVAL STEPS**
1. FLEXIBLE SUCTION HOSE CONNECTION

<<A>>

2. FLEXIBLE DISCHARGE HOSE CONNECTION

<<B>>

### REMOVAL STEPS (Continued)

<<C>> >>A<<

3. O RING
4. DRIVE BELT
5. A/C COMPRESSOR
6. A/C COMPRESSOR BRACKET

## REMOVAL SERVICE POINTS

### <<A>> FLEXIBLE SUCTION HOSE AND FLEXIBLE DISCHARGE HOSE DISCONNECTION

#### **⚠ CAUTION**

As the compressor oil and receiver are highly moisture absorbent, use a non-porous material to plug the hose and nipples.

To prevent the entry of dust or other foreign bodies, plug the dismantled hoses and compressor nipples.

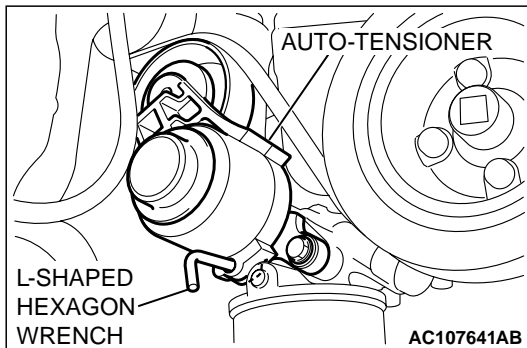
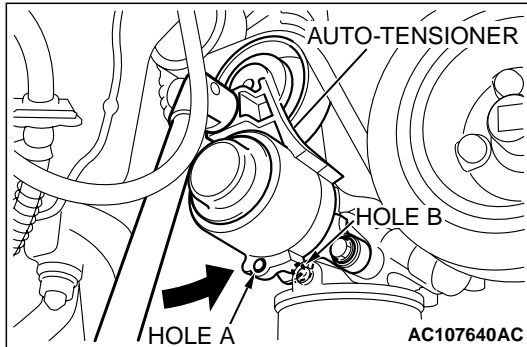
**<<B>> DRIVE BELT REMOVAL**

The following operations will be needed due to the serpentine drive system with the drive belt auto-tensioner.

1. Securely insert the spindle handle or ratchet handle with a 12.7mm (1/2-inch) insertion angle into the jig hole of the auto-tensioner, and turn the auto-tensioner counterclockwise until it hits the stopper.

**⚠ CAUTION**

To reuse the drive belt, draw an arrow indicating the rotating direction (to the right) on the back of the belt using chalk, etc.

2. Align hole A with hole B, insert an L-shaped hexagon wrench, etc. to fix and then remove the drive belt.

**<<C>> A/C COMPRESSOR REMOVAL**

Take care not to spill any compressor oil when removing the compressor.

**INSTALLATION SERVICE POINT****>>A<< A/C COMPRESSOR INSTALLATION**

If a new compressor is installed, first adjust the amount of oil according to the procedures described below, and then install the compressor.

1. Measure the amount [ $X \text{ cm}^3$  ( $X \text{ floz}$ )] of oil within the removed compressor.
2. Drain (from the new compressor) the amount [ $Y \text{ cm}^3$  ( $Y \text{ floz}$ )] of oil calculated according to the following formula, and then install the new compressor.

$$\text{New compressor oil amount} = 130 \text{ cm}^3 (4.7 \text{ floz})$$

$$130 \text{ cm}^3 - X \text{ cm}^3 = Y \text{ cm}^3 (4.7 \text{ floz} - X \text{ floz} = Y \text{ floz})$$

*NOTE:  $Y \text{ cm}^3$  ( $Y \text{ floz}$ ) indicates the amount of oil in the refrigerant line, the condenser, the evaporator, etc.*

*NOTE: When replacing the following parts at the same times as the compressor, subtract the rated oil amount of the each part from  $Y \text{ cm}^3$  ( $Y \text{ floz}$ ) and discharge from the new compressor.*

**Quantity:**

- Evaporator:  $60 \text{ cm}^3$  (2.0 floz)
- Condenser:  $15 \text{ cm}^3$  (0.5 floz)
- Suction hose:  $10 \text{ cm}^3$  (0.3 floz)
- Receiver:  $10 \text{ cm}^3$  (0.3 floz)



INSPECTION

M1552014300563

COMPRESSOR MAGNETIC CLUTCH OPERATION CHECK

Connect the compressor connector terminal to the battery positive (+) terminal and ground the battery's negative (-) terminal to the compressor unit. At that time, the magnetic clutch should make a definite operating sound.

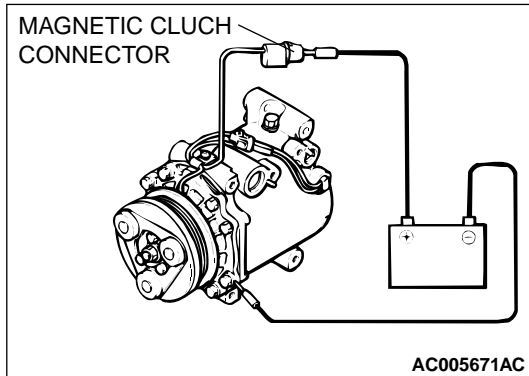

DISASSEMBLY AND ASSEMBLY

M1552004600358

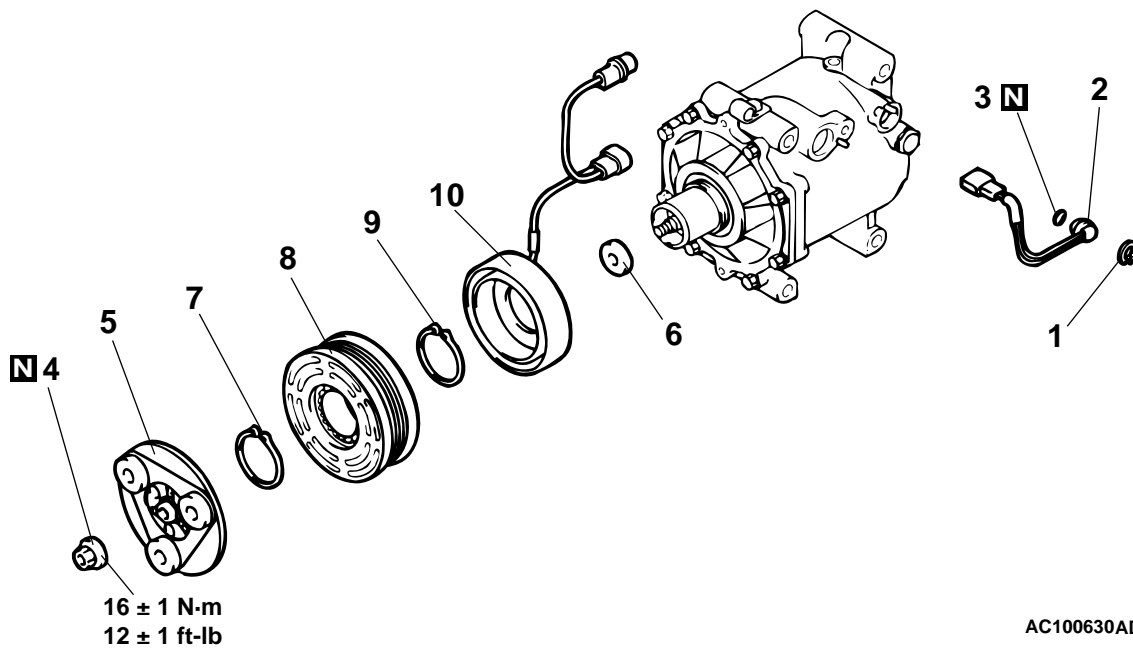

COOLING TEMPERATURE SWITCH DISASSEMBLY STEPS

1. SNAP RING
2. COOLING TEMPERATURE SWITCH
3. O-RING

MAGNETIC CLUTCH DISASSEMBLY

- >>D<< • AIR GAP ADJUSTMENT
- <<A>> >>C<< 4. SELF-LOCKING NUT
- 5. ARMATURE
- 6. SHIM

MAGNETIC CLUTCH DISASSEMBLY (Continued)

- >>B<< 7. SNAP RING
- 8. ROTOR
- 9. SNAP RING
- >>A<< 10. FIELD CORE

Required Special Tools:

- MB991367: Special Spanner
- MB991386: Pin

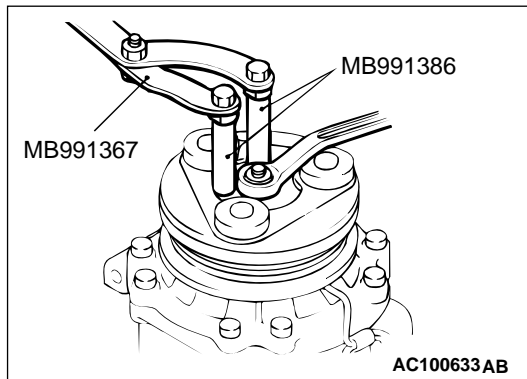
**DISASSEMBLY SERVICE POINT****<<A>> SELF-LOCKING NUT REMOVAL****ASSEMBLY SERVICE POINTS****>>A<< FIELD CORE ATTACHMENT**

Line up the pin hole on the compressor unit with the field core projection and attach.

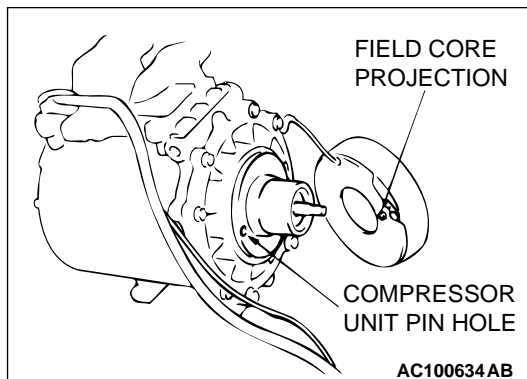
**>>B<< SNAP RING INSTALLATION**

Using snap ring pliers, fit the snap ring so that the snap ring's tapered part is on the outside.

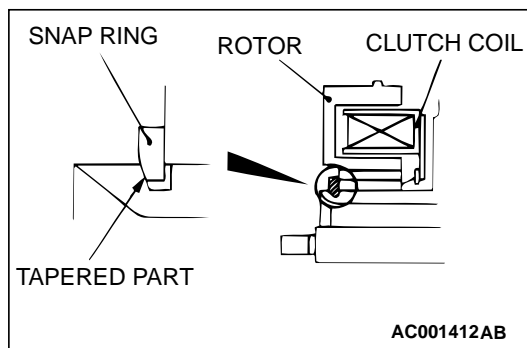
**>>C<< SELF-LOCKING NUT INSTALLATION**

Using a special tool, as when removing the nut, secure the armature and tighten the self-locking nut.

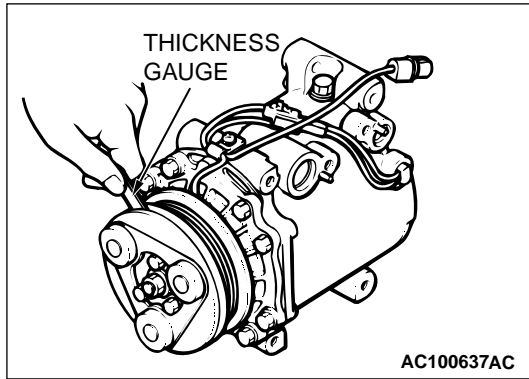

**>>D<< AIR GAP ADJUSTMENT**

Apply voltage from the battery to the magnetic clutch and check that the clutch air gap is inside the standard value. If outside the standard value, use a shim to adjust the gap.

**Standard value: 0.3 – 0.5 mm (0.012 – 0.020 inch)**

**INSPECTION**

M1552014300574

**REFRIGERANT TEMPERATURE SWITCH**

**⚠ CAUTION**

**Do not heat more than necessary.**

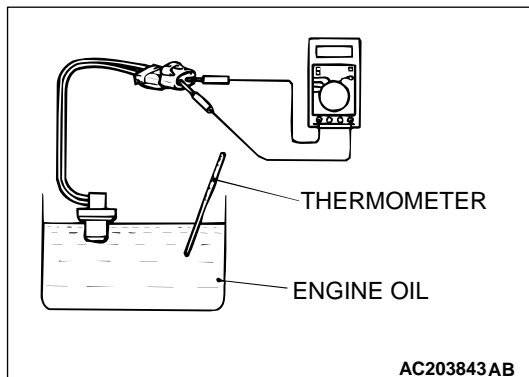

1. Dip the metal part of the refrigerant temperature switch into engine oil and increase the oil temperature using a gas burner or similar.

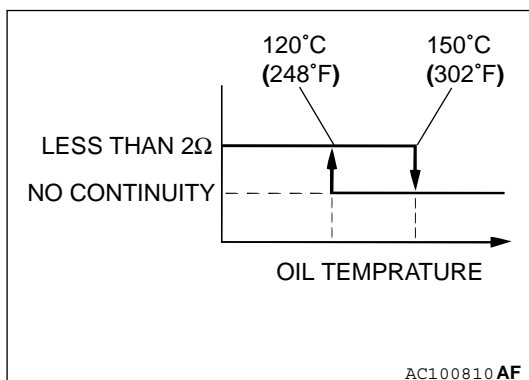

2. When the oil temperature reaches the standard value, check that voltage is supplied between the terminals.

**Standard value:**

ITEM	TEMPERATURE
Less than 2 ohms	Slightly below 150°C (302°F)
No continuity	150°C (302°F) or more

*NOTE: When the oil temperature is 150°C (302°F) or more and there is no continuity, the resistance will not be 2Ω or lower until the oil temperature reduces to 120°C (248°F) or less.*

# CONDENSER AND CONDENSER FAN MOTOR

## REMOVAL AND INSTALLATION

M1552006700306

**Pre-removal and Post-installation Operation**

- Refrigerant Draining and Refilling (Refer to P.55-71.)
- Front Bumper Removal and Installation (Refer to GROUP 51 P.51-5.)

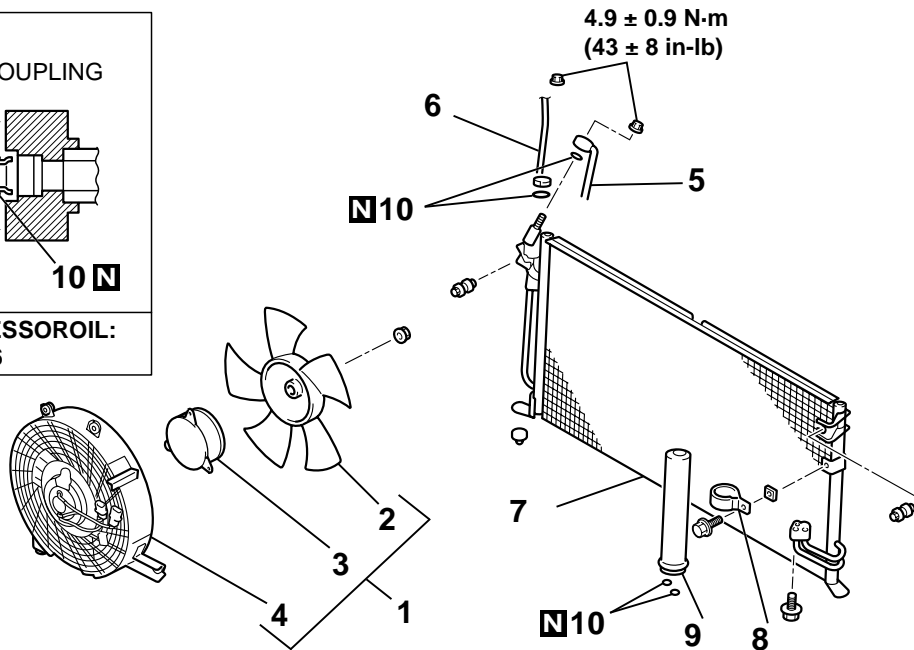
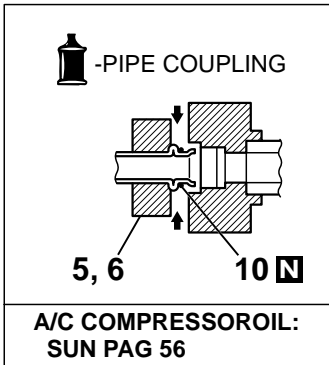

AC211410AB

**FAN SHROUD ASSEMBLY  
REMOVAL STEPS**

<<A>>

1. FAN SHROUD ASSEMBLY
2. FAN
3. FAN MOTOR
4. FAN SHROUD

**CONDENSER REMOVAL STEPS**

<<B>>

5. FLEXIBLE DISCHARGE HOSE CONNECTION
6. LIQUID PIPE A CONNECTION
7. CONDENSER
8. CLAMP
9. RECEIVER
10. O-RING

<<B>>

>>A<<

### REMOVAL SERVICE POINT

**<<A>> SHROUD ASSEMBLY REMOVAL**

1. Remove the intercooler mounting bolts/nuts and pull the intercooler forward.
2. Move the fan motor/shroud assembly upward for removal.

**<<B>> FLEXIBLE DISCHARGE HOSE AND LIQUID PIPE A DISCONNECTION**

**CAUTION**

As the compressor oil and receiver are highly moisture absorbent, use a non-porous material to plug the hose and nipples.

To prevent the entry of dust or other foreign bodies, plug the dismantled hose and condenser assembly nipples.

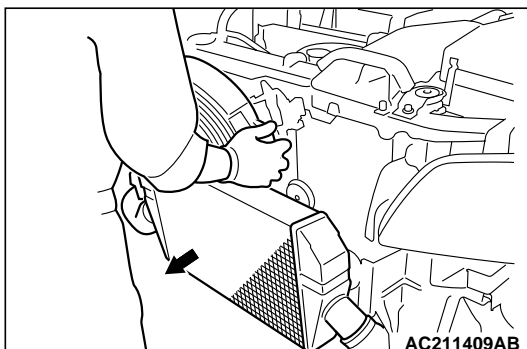

**INSTALLATION SERVICE POINT**

**>>A<< CONDENSER INSTALLATION**

When replacing the condenser, refill it with a specified amount of compressor oil and install it. (to the vehicle).

**Compressor oil: SUN PAG 56**

**Quantity: 15 cm<sup>3</sup> (0.5 floz)**

**INSPECTION**

M1552014300585

**CONDENSER FAN MOTOR CHECK**

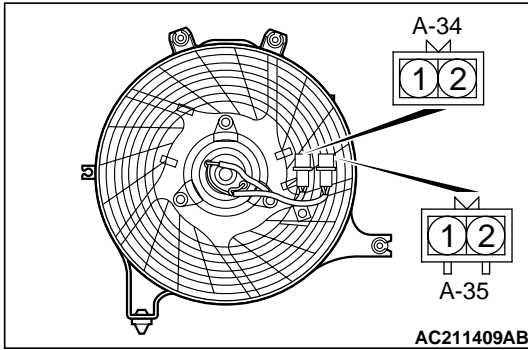

BATTERY CONNECTION	CONDENSER FAN MOTOR OPERATION
<ul style="list-style-type: none"> <li>• Connect connector A-34 terminal 2 to the positive battery terminal</li> <li>• Connect connector A-35 terminal 2 to the negative battery terminal</li> </ul>	Condenser fan motor LO operation
<ul style="list-style-type: none"> <li>• Connect connector A-34 terminal 1 to the positive battery terminal</li> <li>• Connect connector A-35 terminal 2 to the negative battery terminal</li> </ul>	Condenser fan motor HI operation

# REFRIGERANT LINE

## REMOVAL AND INSTALLATION

M1552006400349

**Pre-removal and Post-installation Operation**

- Refrigerant Draining and Refilling (Refer to P.55-71.)
- Air Cleaner Removal and Installation (Refer to GROUP 15 Air Cleaner P.15-7.)

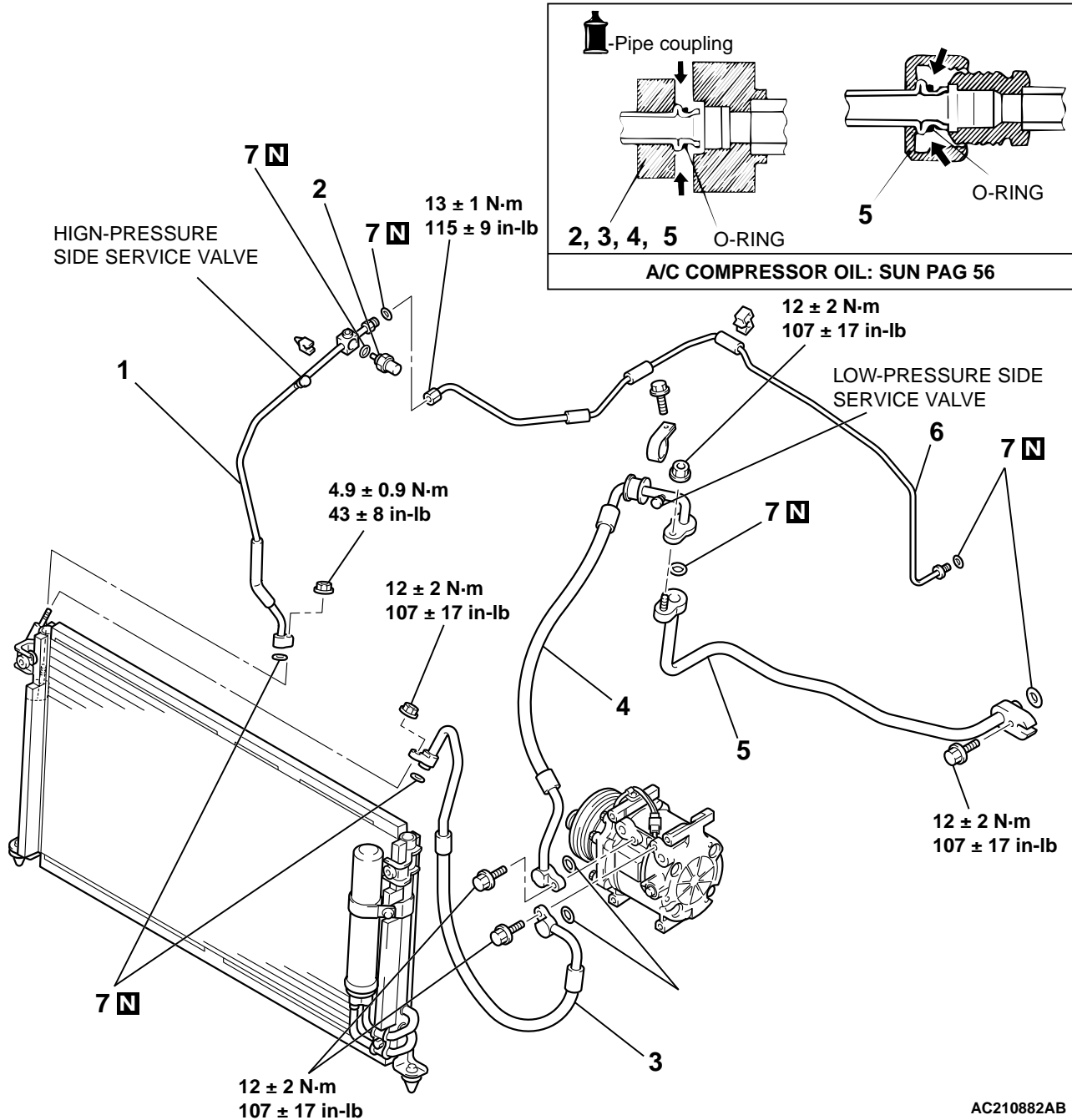

- REMOVAL STEPS**
- <<A>> 1. LIQUID PIPE A
  - <<A>> 2. DUAL PRESSURE SWITCH
  - <<A>> 3. FLEXIBLE DISCHARGE HOSE
  - <<A>> >>A<< 4. FLEXIBLE SUCTION HOSE

- REMOVAL STEPS (Continued)**
- <<A>> 5. SUCTION PIPE
  - <<A>> 6. LIQUID PIPE B
  - 7. O-RING

**REMOVAL SERVICE POINT**

<<A>> LIQUID PIPE A, FLEXIBLE DISCHARGE HOSE, FLEXIBLE SUCTION HOSE, SUCTION PIPE, LIQUID PIPE B, DISCONNECTION

**⚠ CAUTION**

As the compressor oil and receiver are highly moisture absorbent, use a non-porous material to plug the hose and nipples.

To prevent the entry of other foreign bodies, plug the condenser, compressor, and expansion valve nipples.

**INSTALLATION SERVICE POINT**

>>A<< FLEXIBLE SUCTION HOSE INSTALLATION

When replacing the suction hose, refill them with a specified amount of compressor oil, and then install them.

**Compressor oil: SUN PAG 56**

**Quantity: 10 cm<sup>3</sup> (0.3 floz)**

**VENTILATORS**

**REMOVAL AND INSTALLATION**

M1553001600277

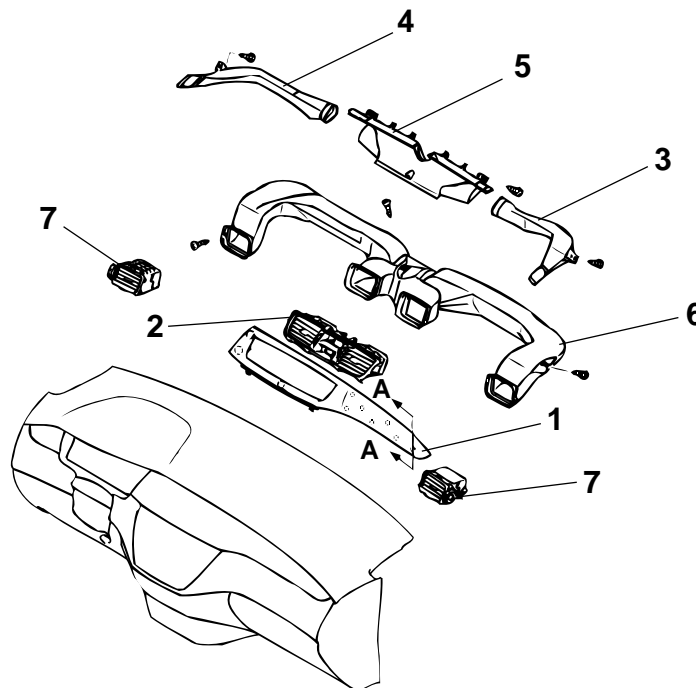
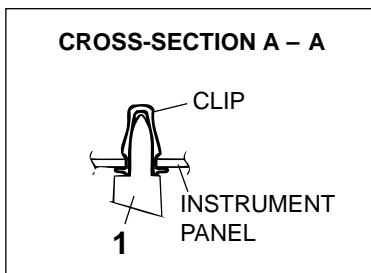

AC211839AB

**AIR OUTLET REMOVAL STEPS**

1. CENTER AIR OUTLET PANEL
2. CENTER AIR OUTLET

**DEFROSTER NOZZLE AND  
DISTRIBUTION DUCT REMOVAL  
STEPS**

- INSTRUMENT PANEL ASSEMBLY  
(REFER TO GROUP 52A  
INSTRUMENT PANEL P.52A-3.)
- 3. RIGHT-HAND SIDE DEFROSTER  
DUCT
- 4. LEFT -HAND SIDE DEFROSTER  
DUCT
- 5. DEFROSTER NOZZLE
- 6. DISTRIBUTION DUCT
- 7. SIDE AIR OUTLET

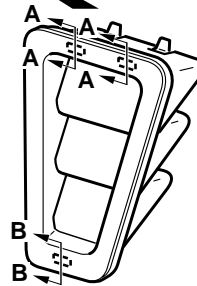
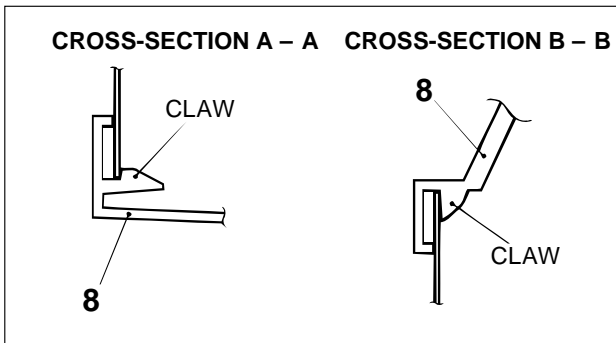
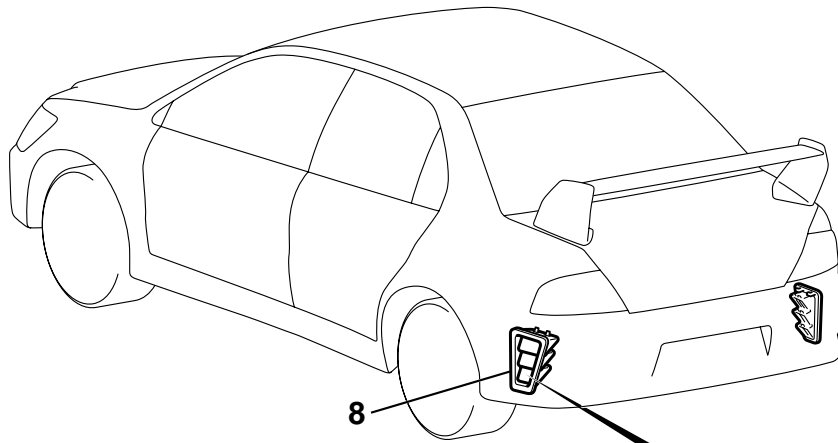

AC211528AB

**REAR VENTILATION DUCT  
REMOVAL STEPS**

- 8. REAR VENTILATION DUCT



## SPECIFICATIONS

### FASTENER TIGHTENING SPECIFICATION

M1552012100239

ITEM	SPECIFICATION
Liquid pipe A mounting nut (condenser side)	4.9 ± 1.0 N·m (43 ± 8 in-lb)
Flexible discharge hose mounting nut (condenser side)	12 ± 2 N·m (107 ± 17 in-lb)
Flexible discharge hose mounting nut (compressor side)	12 ± 2 N·m (107 ± 17 in-lb)
Flexible suction hose mounting nut (suction pipe connection)	12 ± 2 N·m (107 ± 17 in-lb)
Suction pipe mounting bolt (heater unit side)	12 ± 2 N·m (107 ± 17 in-lb)
Liquid pipe A mounting nut (liquid pipe b connection)	4.9 ± 1.0 N·m (43 ± 8 in-lb)

### GENERAL SPECIFICATION

M1552000200206

ITEM	MANUAL AIR CONDITIONING		
Heater/cooler unit	Full-air mix type providing stratified cool and warm air flows		
Heater control	Dial type		
Air conditioning switch	Push-button type		
Compressor	MSC90C (Scroll type)		
Dual pressure switch kPa (psi)	High-pressure switch	ON to OFF	2,940 ± 180 (426.7 ± 26.1)
		OFF to ON	2,350 ± 200 (341.4 ± 29.0)
	Low-pressure switch	ON to OFF	196 ± 20 (28.4 ± 2.9)
		OFF to ON	221 ± 20 (32.1 ± 2.9)
Refrigerant	Type	R134a (HFC-134a)	
	Amount g (oz)	480 – 520 (16.93 – 18.34)	

### SERVICE SPECIFICATIONS

M1552000300247

ITEMS	STANDARD VALUE	
Idle speed r/min	850 ± 100*	
Idle-up speed r/min	850 ± 100*	
Resistor (for blower motor) Ω	LO	2.54
	ML	1.24
	MH	0.6
Air gap (magnetic clutch) mm (in)	0.3 – 0.5 (0.012 – 0.020)	

*NOTE: The r/min marked by an asterisk should be checked 4 minutes after idling begins.*

### LUBRICANT

M1552000400255

ITEM	SPECIFIED LUBRICANT	QUANTITY
Each connection of refrigerant line	SUN PAG 56	As required
Compressor refrigerant unit lubricant cm <sup>3</sup> (floz)	SUN PAG 56	120 – 140 (4.2 – 4.9)

---

## NOTES