

## GROUP 13A

# MULTIPOINT FUEL INJECTION (MFI)

## CONTENTS

<b>GENERAL DESCRIPTION</b> .....	<b>13A-3</b>	MULTIPOINT FUEL INJECTION (MFI) RELAY CONTINUITY CHECK.....	<b>13A-767</b>
<b>MULTIPOINT FUEL INJECTION (MFI) DIAGNOSIS</b> .....	<b>13A-6</b>	FUEL PUMP RELAY CONTINUITY CHECK.....	<b>13A-768</b>
TROUBLESHOOTING STRATEGY.....	13A-6	FUEL PUMP RESISTOR CHECK.....	<b>13A-769</b>
DIAGNOSTIC FUNCTION.....	13A-6	INTAKE AIR TEMPERATURE SENSOR CHECK.....	<b>13A-769</b>
FAIL-SAFE FUNCTION REFERENCE TABLE.....	13A-24	ENGINE COOLANT TEMPERATURE SENSOR CHECK.....	<b>13A-769</b>
DIAGNOSTIC TROUBLE CODE CHART..	13A-25	THROTTLE POSITION SENSOR CHECK..	<b>13A-770</b>
SYMPTOM CHART.....	13A-27	HEATED OXYGEN SENSOR CHECK....	<b>13A-771</b>
DIAGNOSTIC TROUBLE CODE PROCEDURES.....	13A-30	CLUTCH PEDAL POSITION SWITCH CHECK.....	<b>13A-773</b>
SYMPTOM PROCEDURES.....	13A-551	INJECTOR CHECK.....	<b>13A-773</b>
DATA LIST REFERENCE TABLE.....	13A-723	INJECTOR RESISTOR CHECK.....	<b>13A-774</b>
ACTUATOR TEST REFERENCE TABLE..	13A-732	IDLE AIR CONTROL MOTOR (STEPPER MOTOR) CHECK.....	<b>13A-774</b>
CHECK AT THE ENGINE CONTROL MODULE (ECM).....	13A-734	FUEL PRESSURE SOLENOID CHECK...	<b>13A-776</b>
INSPECTION PROCEDURE USING AN OSCILLOSCOPE.....	13A-739	EVAPORATIVE EMISSION PURGE SOLENOID CHECK.....	<b>13A-776</b>
<b>SPECIAL TOOLS</b> .....	<b>13A-751</b>	EGR VACUUM REGULATOR SOLENOID VALVE CHECK.....	<b>13A-776</b>
<b>ON-VEHICLE SERVICE</b> .....	<b>13A-753</b>	EVAPORATIVE EMISSION VENTILATION SOLENOID CHECK.....	<b>13A-776</b>
COMPONENT LOCATION.....	13A-753	TURBOCHARGER WASTEGATE SOLENOID CHECK.....	<b>13A-776</b>
THROTTLE BODY (THROTTLE VALVE AREA) CLEANING.....	13A-758	<b>INJECTOR</b> .....	<b>13A-777</b>
THROTTLE POSITION SENSOR ADJUSTMENT.....	13A-758	REMOVAL AND INSTALLATION.....	<b>13A-777</b>
BASIC IDLE SPEED ADJUSTMENT.....	13A-760	<b>THROTTLE BODY ASSEMBLY</b> .....	<b>13A-779</b>
FUEL PRESSURE TEST.....	13A-762	REMOVAL AND INSTALLATION.....	<b>13A-779</b>
FUEL PUMP CONNECTOR DISCONNECTION (HOW TO REDUCE PRESSURIZED FUEL LINES).....	13A-765	DISASSEMBLY AND ASSEMBLY.....	<b>13A-780</b>
FUEL PUMP OPERATION CHECK.....	13A-766		

Continued on next page

## **ENGINE CONTROL RESISTOR, RELAY 13A-782**

ENGINE CONTROL RESISTOR, RELAY REMOVAL AND INSTALLATION ..... 13A-782

## **ENGINE CONTROL MODULE (ECM) 13A-783**

ENGINE CONTROL MODULE (ECM) REMOVAL AND INSTALLATION..... 13A-783

## **SPECIFICATIONS ..... 13A-783**

FASTENER TIGHTENING SPECIFICATIONS..... 13A-783  
GENERAL SPECIFICATIONS ..... 13A-784  
SERVICE SPECIFICATIONS ..... 13A-784  
SEALANT AND ADHESIVE ..... 13A-785

## GENERAL DESCRIPTION

M1131000100615

The Multiport Fuel Injection System consists of sensors, actuators and the engine control module (ECM). The sensors detect the engine condition. The module controls the system based on signals from these sensors. The actuators work under the control of the ECM. The ECM carries out activities such as fuel injection control, idle air control, and ignition timing control. In addition, the ECM is equipped with several diagnostic test modes which simplify troubleshooting when a problem develops.

### FUEL INJECTION CONTROL

The ECM controls injection drive times and injector timing to supply the optimum air/fuel mixture to the engine according to the continually-changing engine operation conditions. A single injector is mounted at the intake port of each cylinder. The fuel pump supplies pressurized fuel from the fuel tank to the fuel injectors. The fuel pressure regulator controls the fuel pressure. Thus, the regulated fuel is distributed to each injector. Fuel is normally injected for each cylinder every two rotations of the crankshaft. The firing order is 1-3-4-2. Each cylinder has a dedicated fuel injector. This is called "multiport". The ECM provides a richer air/fuel mixture by carrying out "open-loop" control when the engine is cold or running under high load conditions. Thus, engine performance is maintained. In addition, when the engine is under normal operating temperature after warming-up, the ECM controls the air/fuel mixture according to the heated oxygen sensor signal. This control is a "closed-loop" control. The closed-loop control achieves the theoretical air/fuel mixture ratio where the catalytic converter can obtain the maximum cleaning performance.

### IDLE AIR CONTROL

The engine control module controls the amount of air that bypasses the throttle valve according to changes in idling conditions and engine load during idling. Thus, idle speed is kept at an optimum speed. The ECM drives the idle air control (IAC) motor according to engine coolant temperature, A/C, and other electrical load. Thus, idle speed is kept at an optimum speed. In addition, when the A/C switch is turned off and on while the engine is idling, the IAC motor adjusts the throttle valve bypass air amount. Thus, idle speed is maintained at constant speed regardless of various engine load conditions.

### IGNITION TIMING CONTROL

The ignition power transistor located in the ignition primary circuit turns on and off to control primary current flow to the ignition coil. This maintains ignition timing at an optimum level regardless of various engine operating conditions. The ECM determines the ignition timing according to engine speed, intake air volume, engine coolant temperature, and atmospheric pressure.

### DIAGNOSTIC TEST MODE

- When a fault is detected in any of the sensors or actuators related to emission control, the Malfunction Indicator Lamp (SERVICE ENGINE SOON) illuminates to warn the driver.
- When a fault is detected in one of the sensors or actuators, a diagnostic trouble code corresponding to the fault is stored in the ECM.
- The RAM data inside the ECM that is related to the sensors and actuators can be read with the scan tool. In addition, the actuators can be controlled by the scan tool MB991502 (MUT-II) or MB991958 (MUT-III sub assembly) under certain circumstances.

### OTHER CONTROL FUNCTIONS

#### Fuel Pump Control

- Turns the fuel pump relay ON so that current is supplied to the fuel pump while the engine is cranking or running.

#### A/C Compressor Clutch Relay Control

- Turns the compressor clutch of the A/C ON and OFF.

#### Fan Motor Control

- The radiator fan and condenser fan speeds are controlled in response to the engine coolant temperature and vehicle speed.

#### Fuel Pressure Control

- Supplies current to fuel pressure solenoid coil to raise the fuel pressure so that the fuel does not vaporize when the engine is started while it is warm.

#### Intake Charge Pressure Control

- Control the intake charge pressure by controlling the duty of the turbocharger wastegate solenoid.

#### Generator Output Current Control

- Prevents generator output current from increasing suddenly and idle speed from dropping at times such as when the headlights are turned on.

**Evaporative Emission Purge Control**

- (Refer to GROUP 17, Emission Control System – Evaporative Emission System – General Information [P.17-12.](#))

**EGR Control**

- (Refer to GROUP 17, Emission Control System – Exhaust Gas Recirculation (EGR) System – General Information [P.17-16.](#))

MULTIPOINT FUEL INJECTION (MFI) SYSTEM DIAGRAM

SENSE

- ★ 1 HEATED OXYGEN SENSOR (FRONT)
- ★ 2 VOLUME AIRFLOW SENSOR
- ★ 3 INTAKE AIR TEMPERATURE SENSOR
- ★ 4 THROTTLE POSITION SENSOR
- ★ 5 CAMSHAFT POSITION SENSOR
- ★ 6 CRANKSHAFT POSITION SENSOR
- ★ 7 BAROMETRIC PRESSURE SENSOR
- ★ 8 ENGINE COOLANT TEMPERATURE SENSOR
- ★ 9 KNOCK SENSOR
- ★ 10 HEATED OXYGEN SENSOR (REAR)
- ★ 11 MANIFOLD DIFFERENTIAL PRESSURE SENSOR
- ★ 12 FUEL TANK DIFFERENTIAL PRESSURE SENSOR
- ★ 13 FUEL TEMPERATURE SENSOR
- ★ 14 FUEL LEVEL SENSOR

- POWER SUPPLY
- VEHICLE SPEED SENSOR
- A/C SWITCH
- POWER STEERING PRESSURE SWITCH
- CLUTCH SWITCH
- IGNITION SWITCH - ST

DECIDE

ECM

ACT

- ◆ 1 INJECTOR
  - ◆ 2 EVAPORATIVE EMISSION PURGE SOLENOID
  - ◆ 3 IDLE AIR CONTROL MOTOR
  - ◆ 4 EGR SOLENOID
  - ◆ 5 EVAPORATIVE EMISSION VENTILATION SOLENOID
  - ◆ 6 FUEL PRESSURE SOLENOID
  - ◆ 7 TURBO CHARGER WASTEGATE SOLENOID
- 
- FUEL PUMP RELAY 1, 2, 3
  - MULTIPOINT FUEL INJECTION (MFI) RELAY
  - A/C COMPRESSOR CLUTCH RELAY
  - MALFUNCTION INDICATOR LAMP (SERVICE ENGINE SOON)
  - DIAGNOSTIC OUTPUT
  - IGNITION COIL, IGNITION POWER TRANSISTER

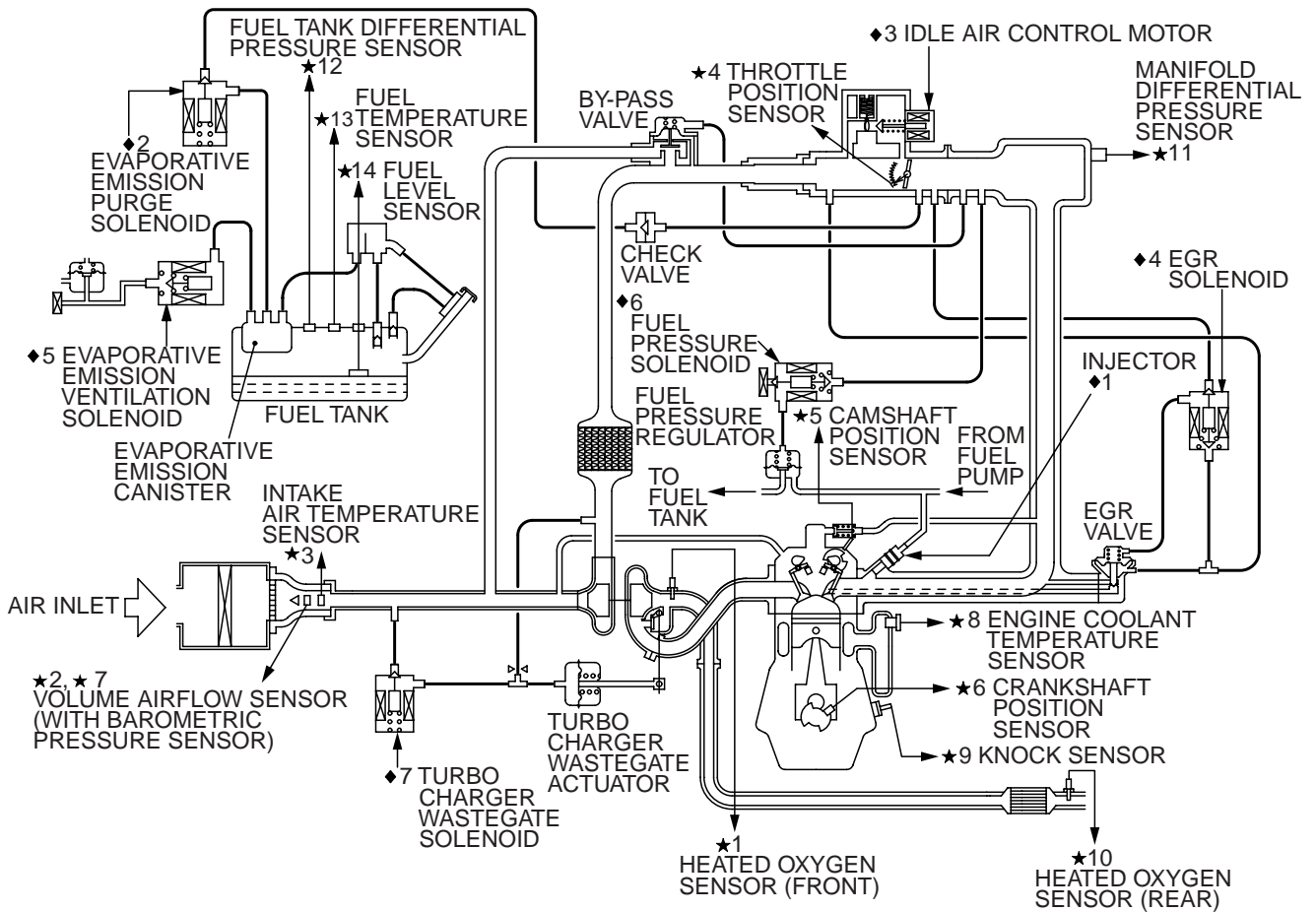

AK200202AB

NOTE: For the vacuum hose routing, refer to GROUP 17, Vacuum Hoses P.17-8.

# MULTIPOINT FUEL INJECTION (MFI) DIAGNOSIS

## TROUBLESHOOTING STRATEGY

Use these steps to plan your diagnostic strategy. If you follow them carefully, you will be sure to have exhausted most of the possible ways to find an MFI fault.

1. Gather as much information as possible about the complaint from the customer.
2. Verify that the condition described by the customer exists.
3. Check the vehicle for any MFI Diagnostic Trouble Code (DTC).
4. If you cannot verify the condition and there are no DTCs, the malfunction is intermittent. For information on how to cope with intermittent malfunctions, refer to GROUP 00, How to Use Troubleshooting/Inspection Service Points – How to cope with Intermittent Malfunction P.00-6.
5. If you can verify the condition but there are no DTCs, or the system cannot communicate with the scan tool, refer to the trouble symptom classification table.

6. If there is a DTC, record the number of the code, then erase the code from the memory using the scan tool.

*NOTE: If a DTC is erased, its "freeze frame" data will be also erased and the system readiness test status will be reset. If necessary, store the "freeze frame" data before erasing the DTC.*

7. Reconfirm the malfunction symptom and carry out a test drive with the drive cycle pattern.
8. If DTC is set again, carry out an inspection with appropriate diagnostic trouble code procedures.
9. If DTC is not set again, the malfunction is intermittent. For information on how to cope with intermittent malfunctions, refer to GROUP 00, How to Use Troubleshooting/Inspection Service Points – How to cope with Intermittent Malfunction P.00-6.
10. After repairs are completed, conduct a road test duplicating the complaint set conditions to confirm the malfunction has been corrected.

M113115000308

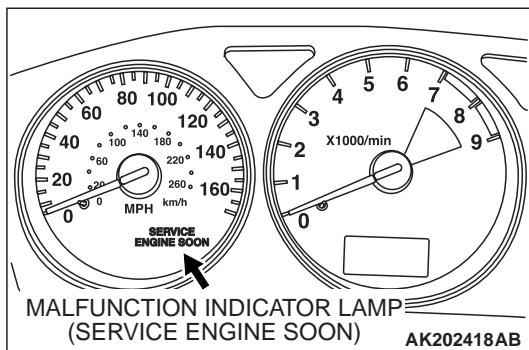

## DIAGNOSTIC FUNCTION

M1131155500029

### MALFUNCTION INDICATOR LAMP (SERVICE ENGINE SOON)

Among the on-board diagnostic items, a Malfunction Indicator Lamp (SERVICE ENGINE SOON) illuminates to notify the driver of an emission control malfunction.

However, when an irregular signal returns to normal and the engine control module (ECM) judges that it has returned to normal, the Malfunction Indicator Lamp (SERVICE ENGINE SOON) is switched off.

Moreover, when the ignition switch is turned off, the lamp is switched off. Even if the ignition switch is turned on again, the lamp does not illuminate until the malfunction is detected.

Immediately after the ignition switch is turned on, the Malfunction Indicator Lamp (SERVICE ENGINE SOON) is lit for 20 seconds to indicate that the Malfunction Indicator Lamp (SERVICE ENGINE SOON) operates normally.

**Items Indicated by the Malfunction Indicator Lamp (SERVICE ENGINE SOON)**

<b>DTC NO.</b>	<b>ITEMS</b>
–	Engine control module (ECM) malfunction
P0090	Fuel pressure solenoid circuit
P0101*	Volume airflow circuit range/performance problem
P0102*	Volume airflow circuit low input
P0106*	Barometric pressure circuit range/performance problem
P0107*	Barometric pressure circuit low input
P0108*	Barometric pressure circuit high input
P0111*	Intake air temperature circuit range/performance problem
P0112*	Intake air temperature circuit low input
P0113*	Intake air temperature circuit high input
P0116*	Engine coolant temperature circuit range/performance problem
P0117*	Engine coolant temperature circuit low input
P0118*	Engine coolant temperature circuit high input
P0121*	Throttle position sensor circuit range/performance problem
P0122*	Throttle position sensor circuit low input
P0123*	Throttle position sensor circuit high input
P0125*	Insufficient coolant temperature for closed loop fuel control
P0128	Coolant thermostat (Coolant temperature below thermostat regulating temperature)
P0130	Heated oxygen sensor circuit (sensor 1)
P0131	Heated oxygen sensor circuit low voltage (sensor 1)
P0132	Heated oxygen sensor circuit high voltage (sensor 1)
P0133	Heated oxygen sensor circuit slow response (sensor 1)
P0134*	Heated oxygen sensor circuit no activity detected (sensor 1)
P0135	Heated oxygen sensor heater circuit (sensor 1)
P0136	Heated oxygen sensor circuit (sensor 2)
P0137	Heated oxygen sensor circuit low voltage (sensor 2)
P0138	Heated oxygen sensor circuit high voltage (sensor 2)
P0139	Heated oxygen sensor circuit slow response (sensor 2)
P0141	Heated oxygen sensor heater circuit (sensor 2)
P0171	System too lean
P0172	System too rich
P0181	Fuel tank temperature sensor circuit range/performance
P0182	Fuel tank temperature sensor circuit low input
P0183	Fuel tank temperature sensor circuit high input
P0201	Injector circuit-cylinder 1
P0202	Injector circuit-cylinder 2
P0203	Injector circuit-cylinder 3
P0204	Injector circuit-cylinder 4
P0234	Turbocharger wastegate system malfunction

<b>DTC NO.</b>	<b>ITEMS</b>
P0243	Turbocharger wastegate solenoid circuit
P0300	Random/multiple cylinder misfire detected
P0301	Cylinder 1 misfire detected
P0302	Cylinder 2 misfire detected
P0303	Cylinder 3 misfire detected
P0304	Cylinder 4 misfire detected
P0325	Knock sensor circuit
P0335*	Crankshaft position sensor circuit
P0340*	Camshaft position sensor circuit
P0401	Exhaust gas recirculation flow insufficient detected
P0403	Exhaust gas recirculation control circuit
P0421	Warm up catalyst efficiency below threshold
P0441	Evaporative emission system incorrect purge flow
P0442	Evaporative emission system leak detected (Small leak)
P0443	Evaporative emission system purge control valve circuit
P0446	Evaporative emission system vent control circuit
P0451	Evaporative emission system pressure sensor range/performance
P0452	Evaporative emission system pressure sensor low input
P0453	Evaporative emission system pressure sensor high input
P0455	Evaporative emission system leak detected (Gross leak)
P0456	Evaporative emission system leak detected (Very small leak)
P0461	Fuel level sensor circuit range/performance (sensor 1)
P0500	Vehicle speed sensor
P0506	Idle control system RPM lower than expected
P0507	Idle control system RPM higher than expected
P0551	Power steering pressure sensor circuit range/performance
P0554	Power steering pressure sensor circuit intermittent
P1400	Manifold differential pressure sensor circuit malfunction
P1603*	Battery backup circuit malfunction
P2066	Fuel level sensor circuit range/performance (sensor 2)

*NOTE: If the Malfunction Indicator Lamp (SERVICE ENGINE SOON) illuminates because of a malfunction of the engine control module (ECM), communication between the scan tool and the ECM is impossible. In this case, the diagnostic trouble code (DTC) cannot be read.*

*NOTE: After the ECM has detected a malfunction, the Malfunction Indicator Lamp (SERVICE ENGINE SOON) illuminates when the engine is next turned on and the same malfunction is re-detected. However, for items marked with a "\*" in the DTC NO column, the Malfunction Indicator Lamp (SERVICE ENGINE SOON) illuminates on the first detection of the malfunction.*

*NOTE: After the Malfunction Indicator Lamp (SERVICE ENGINE SOON) illuminates, it will be switched off under the following conditions.*

- *When the ECM monitored the power train malfunction three times\* it met set condition requirements, it detected no malfunction. \*: In this case, "one time" indicates from engine start to stop.*



- For misfiring or a fuel trim malfunction, when driving conditions (engine speed, engine coolant temperature, etc.) are similar to those when the malfunction was first recorded.

**NOTE:** Sensor 1 indicates the sensor mounted at a position closest to the engine, and sensor 2 indicates the sensor mounted at the position second closest to the engine.

## HOW TO CONNECT THE SCAN TOOL (MUT-III)

### Required Special Tools:

- MB991958: Scan Tool (MUT-III Sub Assembly)
  - MB991824: V.C.I
  - MB991827: USB Cable
  - MB991911: Main Harness B

### **⚠ CAUTION**

To prevent damage to scan tool MB991958, always turn the ignition switch to the "LOCK" (OFF) position before connecting or disconnecting scan tool MB991958.

1. Ensure that the ignition switch is at the "LOCK" (OFF) position.
2. Start up the personal computer.
3. Connect special tool MB991827 to special tool MB991824 and the personal computer.
4. Connect special tool MB991911 to special tool MB991824.
5. Connect special tool MB991911 to the data link connector.
6. Turn the power switch of special tool MB991824 to the "ON" position.

**NOTE:** When the special tool MB991824 is energized, special tool MB991824 indicator light will be illuminated in a green color.

7. Start the MUT-III system on the personal computer.

**NOTE:** Disconnecting the scan tool MB991958 is the reverse of the connecting sequence, making sure that the ignition switch is at the "LOCK" (OFF) position.

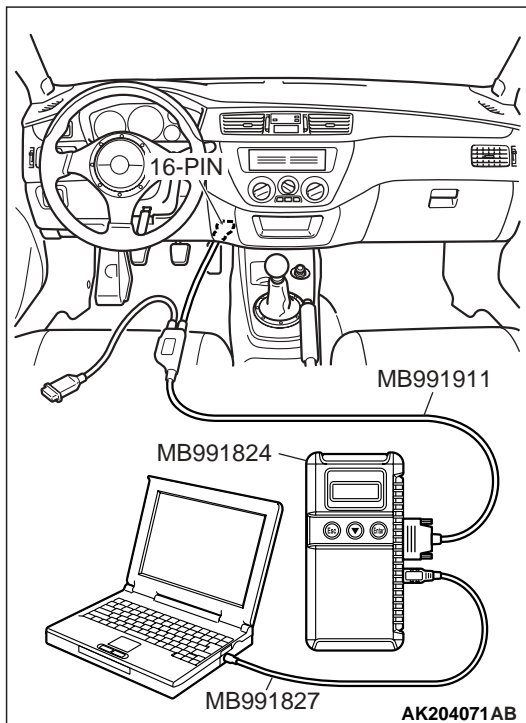

## HOW TO READ AND ERASE DIAGNOSTIC TROUBLE CODE

### <WHEN USING THE MUT-II>

### Required Special Tool:

- MB991502: Scan Tool (MUT-II)

### **⚠ CAUTION**

To prevent damage to scan tool MB991502, always turn the ignition switch to the "LOCK" (OFF) position before connecting or disconnecting scan tool MB991502.

**NOTE:** If Battery positive voltage is low, diagnostic trouble codes may not be output. Be sure to check the battery and charging system before continuing.

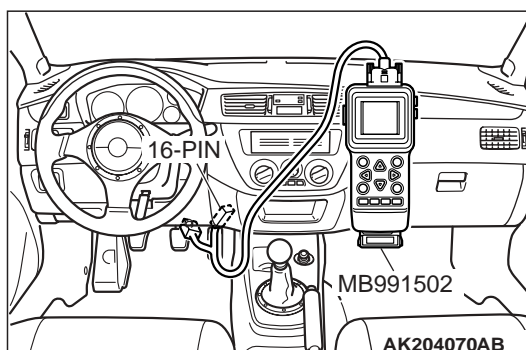

*NOTE: If battery cable is disconnected or if the engine control module (ECM) connector is disconnected, the diagnostic trouble codes will be erased. Do not disconnect the battery cable or ECM connector until the diagnostic trouble codes have been recorded.*

*NOTE: If a DTC is erased, its "freeze frame" data will be also erased and the system readiness test status will be reset. If necessary, store the "freeze frame" data before erasing the DTC.*

1. Connect scan tool MB991502 to the data link connector.
2. Turn the ignition switch to the "ON" position.
3. Read the diagnostic trouble codes for MFI.
4. Refer to the DIAGNOSTIC TROUBLE CODE CHART(P.13A-25).
5. Turn the ignition switch to the "LOCK" (OFF) position and then back to "ON" again.
6. Erase the diagnostic trouble code(s) using MB991502 screen prompts.
7. Confirm that the diagnostic trouble code output is normal.
8. Turn the ignition switch to the "LOCK" (OFF) position.
9. Disconnect scan tool MB991502 from the data link connector.

#### <WHEN USING THE MUT-III>

##### Required Special Tools:

- MB991958: Scan Tool (MUT-III Sub Assembly)
  - MB991824: V.C.I
  - MB991827: USB Cable
  - MB991911: Main Harness B

#### **⚠ CAUTION**

**To prevent damage to scan tool MB991958, always turn the ignition switch to the "LOCK" (OFF) position before connecting or disconnecting scan tool MB991958.**

*NOTE: If the battery voltage is low, diagnostic trouble codes will not be set. Check the battery if scan tool MB991958 does not display.*

1. Connect scan tool MB991958 to the data link connector.
2. Turn the ignition switch to the "ON" position.
3. Select "Interactive Diagnosis" from the start-up screen.
4. Select "System select."
5. Choose "MFI" from the "POWER TRAIN" tab.
6. Select "MITSUBISHI."
7. Select "Diagnostic Trouble Code"
8. If a DTC is set, it is shown.
9. Choose "Erase DTCs" to erase the DTC.

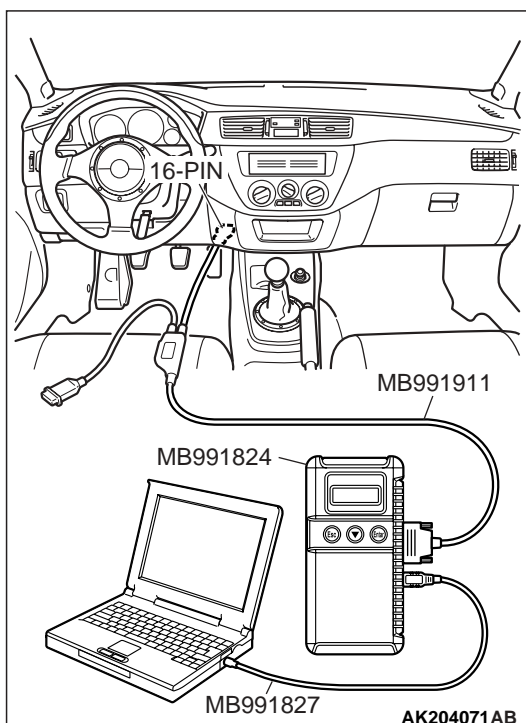

**PROVISIONAL DTCs [SCAN TOOL MB991502 or MB991958 OBD-II Test Mode – Results (Mode 7)]**

The scan tool will display the Provisional DTCs reported by engine control module (ECM) if the ECM detects some malfunction for "Misfire", "Fuel System" and "Comprehensive" monitoring during a SINGLE Driving Cycle. The intended use of this data is to assist the technician after a vehicle repair, and after clearing diagnostic information, by reporting test result after a SINGLE Driving Cycle. Note that the test results reported by this mode do not necessarily indicate a faulty component/system. If test results indicate a failure after ADDITIONAL (consecutive) driving, then the Malfunction Indicator Lamp (SERVICE ENGINE SOON) will be illuminated and a DTC will set.

**MODE 6 REFERENCE TABLE**

The engine control module (ECM) monitors the condition of emission control system.

By selecting MODE 6 using scan tool, Test Result and Limit Value (minimum) \*1 or (maximum) \*2 about the main items of emission control system which ECM monitors can be confirmed. The value at the last monitoring is output by ECM as a test result.

TEST ID	MONITORING ITEM	SIMPLE TECHNICAL DESCRIPTION	INDICATION OF SCAN TOOL	CONVERSION COEFFICIENT IN USING GENERAL SCAN TOOL
01	Catalyst monitor	ECM monitors the deterioration of catalyst by the output frequency ratio between heated oxygen sensor (front) and heated oxygen sensor (rear).	Catalyst Frequency Ratio Test Result and Limit Value (max.)	× 0.0039
03	EGR monitor	ECM monitors the operation of EGR system by the pressure difference of intake manifold between before and after introduction of EGR using the manifold differential pressure sensor.	EGR Monitor Pressure Value Test Result and Limit Value (min.) kPa	× 0.43 kPa
06	Evaporation leak monitor (Small leak)	After PCM vacuumizes the fuel tank and the fuel line and then the specified time is passed, PCM monitors the leak of fuel evaporation gas through the fuel tank differential pressure sensor to check the reduction of vacuum in the fuel tank.	EVAP Leak Mon. 1 mm Pressure Value Test Result and Limit Value (max.) kPa	× 0.032 kPa
07	Evaporation leak monitor (Gross leak)	ECM monitors the leak of fuel evaporation gas by checking whether the pressure can be reduced (the amount of pressure reduction) using the fuel tank differential pressure sensor after sealing the fuel tank and the fuel line.	EVAP Leak Mon. Gross Pressure Value Test Result and Limit Value (min.) kPa	× 0.032 kPa

TEST ID	MONITORING ITEM	SIMPLE TECHNICAL DESCRIPTION	INDICATION OF SCAN TOOL	CONVERSION COEFFICIENT IN USING GENERAL SCAN TOOL
08	Evaporation leak monitor (Very small leak)	After PCM vacuumizes the fuel tank and the fuel line and then the specified time is passed, PCM monitors the leak of fuel evaporation gas through the fuel tank differential pressure sensor to check the reduction of vacuum in the fuel tank.	EVAP Leak Mon. 0.5 mm Pressure Value Test Result and Limit Value (max.) kPa	× 0.032 kPa
09	Heated oxygen sensor (front) monitor (Rich/Lean Switching)	ECM monitors the deteriorated condition of the heated oxygen sensor (front) by checking the lean/rich switching frequency of the heated oxygen sensor (front).	HO2S B1 SENSOR1 Rich/Lean Switching Count Test Result and Limit Value (min.)	× 1 count
0B	Heated oxygen sensor (rear) monitor (Voltage Change)	The engine control unit checks the output voltage of the heated oxygen sensor (rear) in order to monitor whether the heated oxygen sensor (rear) output is stuck.	HO2S B1 SENSOR2 Change in Volt Test Result and Limit Value (min.)	× 19.5 mV

*NOTE: \*1: Minimum value: The test fails if test value is less than this value.*

*NOTE: \*2: Maximum value: The test fails if test value is greater than this value.*

### **DIAGNOSTIC BY DIAGNOSTIC TEST MODE II (INCREASED SENSITIVITY)**

**Required Special Tools:**

- MB991502: Scan Tool (MUT-II)
- MB991958: Scan Tool (MUT-III Sub Assembly)
  - MB991824: V.C.I.
  - MB991827: USB Cable
  - MB991911: Main Harness B

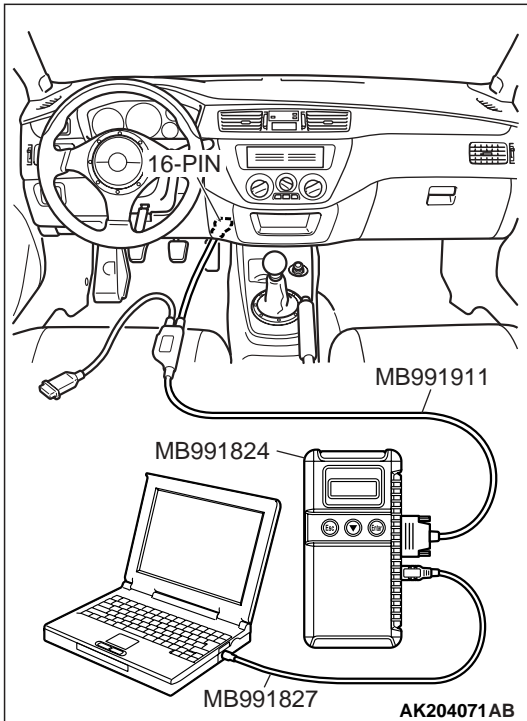
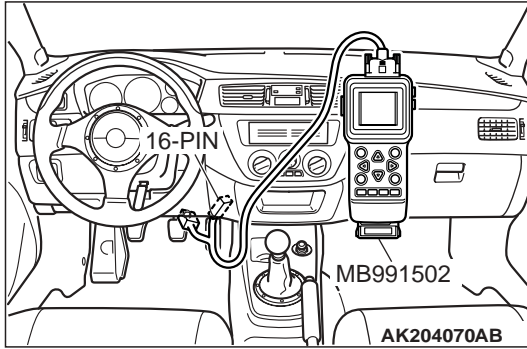

**CAUTION**

To prevent damage to scan tool MB991502 or MB991958, always turn the ignition switch to the "LOCK" (OFF) position before connecting or disconnecting scan tool MB991502 or MB991958.

*NOTE: When mode II is selected with scan tool MB991502 (MUT-II) or MB991958 (MUT-III sub assembly), the Malfunction Indicator Lamp (SERVICE ENGINE SOON) will light when the engine control module (ECM) first detects the trouble (Note that this is only for emission-related trouble). At the same time, the relevant diagnostic trouble codes will be registered. In respect to the comprehensive component electrical faults (opens/shorts), the time for the diagnostic trouble code to be registered after the fault occurrence is four seconds → one second. Therefore, the confirmation of the trouble symptom and the confirmation after completing repairs can be reduced. To return to the normal mode I after mode II has been selected once, the ignition switch must be turned "OFF" once or mode I must be reselected with scan tool MB991502 (MUT-II) or MB991958 (MUT-III sub assembly). The diagnostic trouble code, system readiness test status and freeze frame data, etc., will be erased when mode I is returned to, so record these before returning to mode 1.*

1. Connect scan tool MB991502 or MB991958 to the data link connector.
2. Turn the ignition switch to the "ON" position.
3. Change the diagnostic test mode of the ECM to DIAGNOSTIC TEST MODE II (INCREASED SENSITIVITY).
4. Road test the vehicle.
5. Read the diagnostic trouble code and repair the malfunctioning part.
6. Turn the ignition switch to the "LOCK" (OFF) position.
7. Disconnect scan tool MB991502 or MB991958 from the data link connector.

**INSPECTION USING SCAN TOOL MB991502 or MB991958, DATA LIST AND ACTUATOR TESTING**

<WHEN USING THE SCAN TOOL MB991502>

**Required Special Tool:**

- MB991502: Scan Tool (MUT-II)

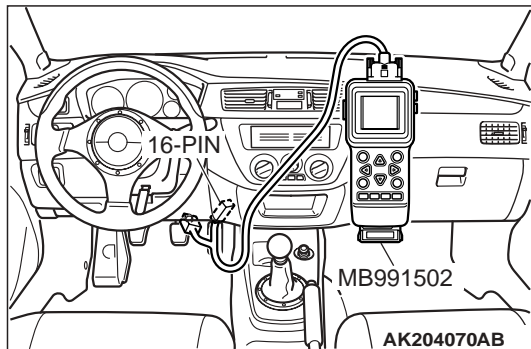

**⚠ CAUTION**

To prevent damage to scan tool MB991502, always turn the ignition switch to the "LOCK" (OFF) position before connecting or disconnecting scan tool MB991502.

1. Connect scan tool MB991502 to the data link connector.
2. Turn the ignition switch to the "ON" position.
3. Carry out inspection by means of the data list and the actuator test function. If there is an abnormality, check and repair the chassis harnesses and components. Refer to Data List Reference Table (P.13A-723).

Refer to Actuator Test Reference Table (P.13A-732).

4. Re-check using scan tool MB991502 and check to be sure that the abnormal input and output have returned to normal because of the repairs.
5. Erase the diagnostic trouble code(s).
6. Turn the ignition switch to the "LOCK" (OFF) position.
7. Disconnect scan tool MB991502 from the data link connector.
8. Start the engine again and do a test drive to confirm that the problem is eliminated.

**<WHEN USING THE SCAN TOOL MB991958>**

**Required Special Tools:**

- MB991958: Scan Tool (MUT-III Sub Assembly)
  - MB991824: V.C.I.
  - MB991827: USB Cable
  - MB991911: Main Harness B

**⚠ CAUTION**

To prevent damage to scan tool MB991958, always turn the ignition switch to the "LOCK" (OFF) position before connecting or disconnecting scan tool MB991958.

1. Connect scan tool MB991958 to the data link connector.
2. Turn the ignition switch to the "ON" position.
3. Select "Interactive Diagnosis" from the start-up screen.
4. Select "System select."
5. Choose "MFI" from the "POWER TRAIN" tab.
6. Select "MITSUBISHI."
7. Select "Data List" or "Actuator Test."
8. Choose an appropriate item and select the "OK" button.

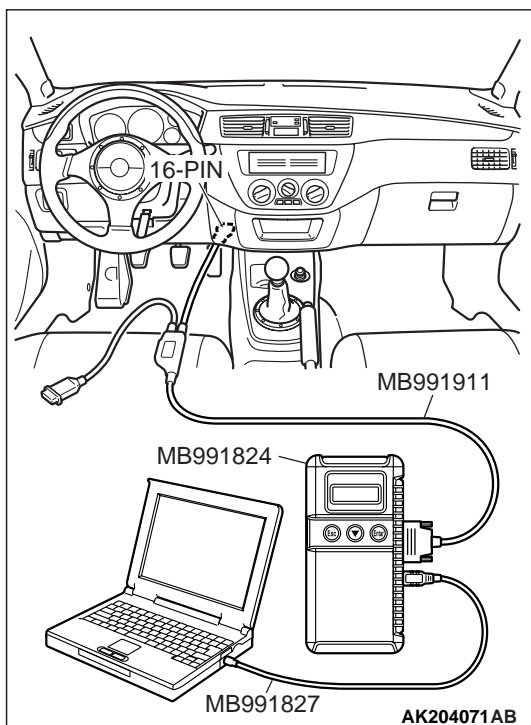

## ON-BOARD DIAGNOSTICS

The engine control module (ECM) monitors the input/output signals (some signals all the time and others under specified conditions) of the ECM. When a malfunction continues for a specified time or longer after the irregular signal is initially monitored, the ECM judges that a malfunction has occurred. After the ECM first detects a malfunction, a diagnostic trouble code is recorded when the engine is restarted and the same malfunction is re-detected. However, for items marked with a "\*", a diagnostic trouble code is recorded on the first detection of the malfunction. There are 71 diagnostic items. The diagnostic results can be read out with a scan tool. Since memorization of the diagnostic trouble codes is backed up directly by the battery, the diagnostic results are memorized even if the ignition key is turned off. The diagnostic trouble codes will, however, be erased when the battery terminal or the ECM connector is disconnected. In addition, the diagnostic trouble code can also be erased by turning the ignition switch to ON and sending the diagnostic trouble code erase signal from scan tool to the ECM.

*NOTE: If the sensor connector is disconnected with the ignition switch turned on, the diagnostic trouble code is memorized. In this case, send the diagnostic trouble code erase signal to the ECM in order to erase the diagnostic memory. The 71 diagnostic items are all indicated sequentially from the smallest code number. The ECM records the engine operating condition when the diagnostic trouble code is set. This data is called "Freeze-frame" data. This data can be read by using the scan tool, and can then be used in simulation tests for troubleshooting. Data items are as follows:*

*NOTE: If the ECM detects multiple malfunctions, the ECM stores the data for only the first item that was detected.*

*However, if the ECM detects a misfire or a fuel system malfunction, the ECM stores the data by giving priority to the misfire or fuel system malfunction, regardless of the order in which the malfunction was detected.*

*NOTE: As for Diagnostic trouble code P1603, "freeze frame" data is not memorized.*

SCAN TOOL DISPLAY	ITEM NO.	DATA ITEM	UNIT or STATE
ECT SENSOR	21	Engine coolant temperature sensor	°C or °F
ENGINE LOAD	87	Calculated load value	%
ENGINE SPEED	22	Crankshaft position sensor	r/min
IAT SENSOR	13	Intake air temperature sensor	°C or °F
IG. TIMING ADV	44	Ignition coils and ignition power transistor	deg
LONG TRIM B1	81	Long-term fuel trim	%
SHORT TRIM B1	82	Short-term fuel trim	%
SYS. STATUS B1	88	Fuel system status	<ul style="list-style-type: none"> <li>• Open loop</li> <li>• Closed loop</li> <li>• Open loop-drive condition</li> <li>• Open loop-DTC set</li> <li>• Closed loop-O<sub>2</sub> (rear) failed</li> </ul>
TP SENSOR	8A	Throttle position sensor	%
VAF SENSOR	12	Volume airflow sensor (mass airflow rate)	gm/s
VSS	24	Vehicle speed sensor	km/h or mph

## OBD- II DRIVE CYCLE

All kinds of diagnostic trouble codes (DTCs) can be monitored by carrying out a short drive according to the following six drive cycle pattern. In other words, doing such a drive regenerates any kind of trouble which involves illuminating the Malfunction Indicator Lamp (SERVICE ENGINE SOON) and verifies the repair procedure has eliminated the trouble (the Malfunction Indicator Lamp (SERVICE ENGINE SOON) is no longer illuminated).

**⚠ CAUTION**

**Two technicians should always be in the vehicle when carrying out a test drive.**

*NOTE: Check that the diagnosis trouble code (DTC) is not output before driving the OBD-II drive cycle. Erase the DTC if it has been output.*

### DRIVE CYCLE PATTERN LIST

PROCEDURE	MONITOR ITEM		DIAGNOSTIC TROUBLE CODE (DTC)
1	Evaporative emission system leak monitor		P0441, P0442, P0451, P0452, P0453, P0455, P0456
2	Fuel trim monitor		P0171, P0172
3	Catalytic converter monitor		P0421
4	Heated oxygen sensor monitor		P0133, P0139
5	Exhaust gas recirculation (EGR) system monitor		P0401
6	Other monitor	Main components	P0134, P0300, P0301, P0302, P0303, P0304, P0506, P0507, P1400
		Sensors and switches	P0101, P0102, P0106, P0107, P0108, P0111, P0112, P0113, P0116, P0117, P0118, P0121, P0122, P0123, P0125, P0181, P0182, P0183, P0335, P0340, P0461, P2066
		Wire breakage and short circuit	P0090, P0130, P0131, P0132, P0135, P0136, P0137, P0138, P0141, P0201, P0202, P0203, P0204, P0243, P0403, P0443, P0446



PROCEDURE 1

EVAPORATIVE EMISSION SYSTEM LEAK MONITOR	
DTC	P0441, P0442, P0451, P0452, P0453, P0455, P0456
Drive cycle pattern	<p>This monitor [from start to ignition switch to the "LOCK" (OFF) position] will be completed while driving the vehicle with the following drive cycle pattern. It will take 8 minutes. You must complete this drive twice.</p> <p><i>NOTE: Vehicle speed and throttle opening angle should be within the shaded range.</i></p> <p>AKX01345 AC</p>
Inspection conditions	<ul style="list-style-type: none"> <li>• Engine coolant temperature: 45°C (113°F) or less (The engine is stopped before the test drive is started)</li> <li>• Atmospheric temperature: 5 – 45°C (41 – 113°F)</li> </ul>

**EVAPORATIVE EMISSION SYSTEM LEAK MONITOR**

## Test procedure

1. Engine: start
2. Accelerate until the vehicle speed is 89 – 97 km/h (55 – 60 mph).
3. Travel for 200 seconds or more while keeping the vehicle speed at 89 – 97 km/h (55 – 60 mph). (M/T: 5th speed)
4. While keeping the accelerator pedal opening degree constant, keep the vehicle speed at 89 – 97 km/h (55 – 60 mph) and travel for 150 seconds or more. (During monitor)
5. Return the vehicle to the shop, then turn the ignition switch to "LOCK" (OFF) position.
6. Confirm that the diagnostic trouble code (DTC) is not output.
7. If DTC P0441 is output, refer to GROUP 13A, DTC P0441 – Evaporative Emission System Incorrect Purge Flow [P.13A-358](#).  
If DTC P0442 is output, refer to GROUP 13A, DTC P0442 – Evaporative Emission System Leak Detected (Small Leak) [P.13A-345](#).  
If DTC P0451 is output, refer to GROUP 13A, DTC P0451 – Evaporative Emission System Pressure Sensor Range/performance [P.13A-380](#).  
If DTC P0452 is output, refer to GROUP 13A, DTC P0452 – Evaporative Emission System Pressure Sensor Low Input [P.13A-397](#).  
If DTC P0453 is output, refer to GROUP 13A, DTC P0453 – Evaporative Emission System Pressure Sensor High Input [P.13A-414](#).  
If DTC P0455 is output, refer to GROUP 13A, DTC P0455 – Evaporative Emission System Leak Detected (Gross Leak) [P.13A-431](#).  
If DTC P0456 is output, refer to GROUP 13A, DTC P0456 – Evaporative Emission System Leak Detected (Very Small Leak) [P.13A-447](#).

PROCEDURE 2

FUEL TRIM MONITOR	
DTC	P0171, P0172
Drive cycle pattern	<p>This monitor [from start to ignition switch to the "LOCK" (OFF) position] will be completed while driving the vehicle with the following drive cycle pattern. It will take 35 minutes. You must complete this drive twice.</p> <p><i>NOTE: Vehicle speed and throttle opening angle should be within the shaded range.</i></p> <p style="text-align: right;">AKX01346 AC</p>
Inspection conditions	<ul style="list-style-type: none"> <li>• Engine coolant temperature: 80 – 97°C (176 – 207°F)</li> <li>• Atmospheric temperature: –10 – 60°C (14 – 140°F)</li> </ul>
Test procedure	<ol style="list-style-type: none"> <li>1. Engine: start</li> <li>2. Accelerate until the vehicle speed is 89 – 97 km/h (55 – 60 mph).</li> <li>3. Travel for 30 minutes or more while keeping the vehicle speed at 89 – 97 km/h (55 – 60 mph). (M/T: 5th speed) Carry out one gradual deceleration/acceleration returning to 89 – 97 km/h (55 – 60 mph) within 120 seconds. (During monitor)</li> <li>4. Return the vehicle to the shop, then turn the ignition switch to "LOCK" (OFF) position.</li> <li>5. Confirm that the diagnostic trouble code (DTC) is not output. If DTC P0171 is output, refer to GROUP 13A, DTC P0171 – System too lean <a href="#">P.13A-232</a>. .If DTC P0172 is output, refer to GROUP 13A, DTC P0172 – System too rich <a href="#">P.13A-240</a>.</li> </ol>

PROCEDURE 3

CATALYTIC CONVERTER MONITOR	
DTC	P0421
Drive cycle pattern	<p>This monitor [from start to ignition switch to the "LOCK" (OFF) position] will be completed while driving the vehicle with the following drive cycle pattern. It will take 20 minutes. You must complete this drive cycle twice.</p> <p><i>NOTE: Vehicle speed and throttle opening angle should be within the shaded range.</i></p>
Inspection conditions	<ul style="list-style-type: none"> <li>• Atmospheric temperature: <math>-10^{\circ}\text{C}</math> (<math>14^{\circ}\text{F}</math>) or more</li> <li>• A/C switch: OFF</li> </ul>
Test procedure	<ol style="list-style-type: none"> <li>1. Engine: start</li> <li>2. Accelerate until the vehicle speed is 72 km/h (45 mph).</li> <li>3. Travel for 300 seconds or more while keeping the vehicle speed at 72 – 97 km/h (45 – 60 mph). (M/T: 5th speed)</li> <li>4. Decelerate until the vehicle speed is within 56 – 64 km/h (35 – 40 mph).</li> <li>5. While keeping the accelerator pedal opening degree constant (M/T: 4th speed), keep the vehicle speed at 56 – 64 km/h (35 – 40 mph) and travel for 90 seconds or more. (During monitor)</li> <li>6. Fully close the throttle and decelerate, and keep the deceleration state for 10 seconds. Then, quickly accelerate until the vehicle speed reaches 56 – 64 km/h (35 – 40 mph). Then, repeat steps 5 and 6, and complete six monitor sessions.</li> <li>7. Return the vehicle to the shop, then turn the ignition switch to "LOCK" (OFF) position.</li> <li>8. Confirm that the diagnostic trouble code (DTC) is not output.</li> <li>9. If DTC P0421 is output, refer to GROUP 13A, DTC P0421 – Warm Up Catalyst Efficiency Below Threshold (Bank 1) <a href="#">P.13A-337</a>.</li> </ol>

PROCEDURE 4

HEATED OXYGEN SENSOR MONITOR	
DTC	P0133, P0139
Drive cycle pattern	<p>This monitor [from start to ignition switch to the "LOCK" (OFF) position] will be completed while driving the vehicle with the following drive cycle pattern. It will take 5 minutes. You must complete this drive twice.</p> <p><i>NOTE: Vehicle speed and throttle opening angle should be within the shaded range.</i></p> <p style="text-align: right;">AKX01348 AC</p>
Inspection conditions	<ul style="list-style-type: none"> <li>• Engine coolant temperature: 80°C (176°F) or more</li> <li>• Atmospheric temperature: -10°C (14°F) or more</li> </ul>
Test procedure	<ol style="list-style-type: none"> <li>1. Engine: start</li> <li>2. Accelerate until the vehicle speed is 56 – 64 km/h (35 – 40 mph).</li> <li>3. While keeping the accelerator pedal opening degree constant (M/T: 4th speed), keep the vehicle speed at 56 – 64 km/h (35 – 40 mph) and travel for 120 seconds or more. (During monitor)</li> <li>4. Return the vehicle to the shop, then turn the ignition switch to "LOCK" (OFF) position.</li> <li>5. Confirm that the diagnostic trouble code (DTC) is not output.</li> <li>6. If DTC P0133 is output, refer to GROUP 13A, DTC P0133 – Heated oxygen Sensor Circuit Slow Response (Sensor 1) <a href="#">P.13A-180</a>. If DTC P0139 is output, refer to GROUP 13A, DTC P0139 – Heated oxygen Sensor Circuit Slow Response (Sensor 2) <a href="#">P.13A-220</a>.</li> </ol>

PROCEDURE 5

EXHAUST GAS RECIRCULATION (EGR) SYSTEM MONITOR	
DTC	P0401
Drive cycle pattern	<p>This monitor [from start to ignition switch to the "LOCK" (OFF) position] will be completed while driving the vehicle with the following drive cycle pattern. It will take 10 minutes. You must complete this drive twice.</p> <p><i>NOTE: Vehicle speed and throttle opening angle should be within the shaded range.</i></p> <p>20 SECONDS OR MORE 56 - 64 km/h (35 - 40 mph) M/T: 4TH SPEED</p> <p>20 SECONDS OR MORE</p> <p>VEHICLE SPEED km/h (mph)</p> <p>64 (40) 32 (20) 0</p> <p>(1) (2) (3) (4) (5) (4) (5) (4) (5) (4) (5) (4)</p> <p>1 ST MON-ITOR 2 ND MON-ITOR 7 TH MON-ITOR 8 TH MON-ITOR</p> <p>ENGINE START IGNITION SWITCH: "LOCK" (OFF) position</p> <p>100 50 0</p> <p>CALCULATED LOAD (%)</p> <p>FULL DECEL-ERATION FULL DECEL-ERATION FULL DECEL-ERATION FULL DECEL-ERATION FULL DECEL-ERATION</p> <p style="text-align: right;">AKX01349AC</p>
Inspection conditions	<ul style="list-style-type: none"> <li>• Engine coolant temperature: 80°C (176°F) or more</li> <li>• Atmospheric temperature: 5°C (41°F) or more</li> <li>• A/C switch: OFF</li> </ul>
Test procedure	<ol style="list-style-type: none"> <li>1. Engine: start</li> <li>2. Accelerate until the vehicle speed is 56 – 64 km/h (35 – 40 mph).</li> <li>3. Travel for 20 seconds or more while keeping the vehicle speed at 56 – 64 km/h (35 – 40 mph). (M/T: 4th speed)</li> <li>4. Fully close the throttle from an engine speed of 2,000 – 3,000 r/min, and while keeping the clutch engaged, decelerate to approximately 900 r/min without applying the brakes. Do not steer the handle or turn the light ON/OFF during this time. (During monitor)</li> <li>5. Accelerate until the vehicle speed reaches 56 – 64 km/h (35 – 40 mph), and travel for 20 seconds or more (M/T: 4th speed). Then, repeat steps 4 and 5 and complete 8 monitor sessions.</li> <li>6. Return the vehicle to the shop, then turn the ignition switch to "LOCK" (OFF) position.</li> <li>7. Confirm that the diagnostic trouble code (DTC) is not output.</li> <li>8. If DTC P0401 is output, refer to GROUP 13A, DTC P0401 – Exhaust Gas Recirculation Flow Insufficient detected <a href="#">P.13A-328</a>.</li> </ol>

**PROCEDURE 6**

<b>OTHER MONITOR (Main components, sensors and switches, wire breakage and short circuit)</b>	
DTC	<ul style="list-style-type: none"> <li>• Main components: P0134, P0300, P0301, P0302, P0303, P0304, P0506, P0507, P1400</li> <li>• Sensors and switches: P0101, P0102, P0106, P0107, P0108, P0111, P0112, P0113, P0116, P0117, P0118, P0121, P0122, P0123, P0125, P0181, P0182, P0183, P0335, P0340, P0461, P2066</li> <li>• Wire breakage and short circuit: P0090, P0130, P0131, P0132, P0135, P0136, P0137, P0138, P0141, P0201, P0202, P0203, P0204, P0243, P0403, P0443, P0446</li> </ul>
Drive cycle pattern	<p>This monitor [from start to ignition switch to the "LOCK" (OFF) position] will be completed while driving the vehicle with the following drive cycle pattern. It will take 10 minutes. You must complete this drive twice.</p> <p><i>NOTE: Drive according to the graph below.</i></p> <p align="right">AKX01350 AC</p>
Inspection conditions	<ul style="list-style-type: none"> <li>• Engine coolant temperature: 80°C (176°F) or more</li> <li>• Atmospheric temperature: 5°C (41°F) or more</li> </ul>
Test procedure	<ol style="list-style-type: none"> <li>1. Engine: start</li> <li>2. Accelerate until the vehicle speed is 56 – 64 km/h (35 – 40 mph), and travel for 300 seconds or more. (M/T: 4th speed)</li> <li>3. Return the vehicle to the shop.</li> <li>4. After stopping the vehicle, continue idling for 300 seconds, and then turn the ignition switch to the "LOCK" (OFF) position. Moreover, the vehicle should be set to the following conditions for idling. <ul style="list-style-type: none"> <li>• A/C switch: OFF</li> <li>• Lights and all accessories: OFF</li> <li>• Transmission: Neutral</li> <li>• Steering wheel: Straightforward position</li> </ul> </li> <li>5. Confirm that the diagnostic trouble code (DTC) is not output.</li> <li>6. If a DTC is displayed, refer to Diagnostic Trouble Code Chart <a href="#">P.13A-25</a>.</li> </ol>

## SYSTEM READINESS TEST STATUS

### PURPOSE

The Readiness function (also referred to as I/M Readiness or I/M Flags) indicates if a full diagnostic check has been "Completed" (is "Ready") for each non-continuous monitor. Enhanced I/M State Emission Programs will use the Readiness status (Codes) to see if the vehicle is ready for OBD-II testing. "Incomplete" (Not Ready) codes will be one of the triggers for I/M failure.

### OVERVIEW

The engine control module (ECM) monitors the following main diagnosis items and records whether the evaluation was completed or is incomplete. The Readiness codes were established for the I/M programs, thereby confirming that the vehicle was not tampered with by erasing the diagnostic trouble code(s) (DTC's) before I/M testing. The Readiness and DTC codes can be reset by disconnecting the battery or by erasing the codes with a scan tool. For this reason all Readiness codes must read "Complete" before I/M testing.

When the monitors run and complete, the scan tool will record the Readiness Code as "Complete" (General Scan Tools record as "Ready"). If the monitor did not run completely, the system then reads as "Incomplete" (General Scan Tools record as "Not Ready"). When the vehicle is operating normally and the OBD-II Drive Cycle is carried out, Readiness Code will set as "Complete" on the first drive cycle. If during the first drive cycle a fault is detected then, a second drive is required before the Readiness Code will "Complete." If the fault is still there, then a DTC will set.

- Catalyst: P0421
- Evaporative system: P0442, P0455, P0456
- Heated oxygen sensor: P0133
- Heated oxygen sensor heater: P0135, P0141
- EGR system: P0401

After the Readiness is "Complete," the technician is assured that any DTC's associated with that monitor will be displayed if the system has a problem. That is why some State's I/M programs require the Readiness Code as "Complete" before they check for DTC's.

*NOTE: After a repair is made for a DTC the technician should drive the OBD-II drive cycle checking that the MB991502 or MB991958 records all Readiness as "Complete".*

## FAIL-SAFE FUNCTION REFERENCE TABLE

M1131153000181

When the main sensor malfunctions are detected by the diagnostic test mode, the vehicle is controlled by means of the following defaults.

MALFUNCTION ITEM	CONTROL CONTENTS DURING MALFUNCTION
Volume airflow sensor	<ul style="list-style-type: none"> <li>• Uses the throttle position sensor signal and engine speed signal (crankshaft position sensor signal) for basic injector drive time and basic ignition timing from the pre-set mapping.</li> <li>• Fixes the IAC motor in the appointed position so idle air control is not performed.</li> </ul>
Intake air temperature sensor	Controls as if the intake air temperature is 25°C (77°F).
Throttle position sensor	No increase in fuel injection amount during acceleration due to the unreliable throttle position sensor signal.
Engine coolant temperature sensor	Controls as if the engine coolant temperature is 80°C (176°F). (This control will be continued until the ignition switch is turned to the "LOCK" (OFF) position even though the sensor signal returns to normal.)
Camshaft position sensor	Injects fuel into the cylinders in the order 1-3-4-2 with irregular timing. (After the ignition switch is turned to the "ON," the No.1 cylinder top dead center is not detected at all.)
Barometric pressure sensor	Controls as if the barometric pressure is 101 kPa (30 in Hg).
Knock sensor	Switches the ignition timing from ignition timing for high octane to ignition timing for standard octane fuel.



<b>MALFUNCTION ITEM</b>	<b>CONTROL CONTENTS DURING MALFUNCTION</b>
Heated oxygen sensor <front>	Air/fuel ratio closed loop control is not performed.
Heated oxygen sensor <rear>	Performs the closed loop control of the air/fuel ratio by using only the signal of the heated oxygen sensor (front) installed on the front side of the catalytic converter.
Generator FR terminal	Does not restrict the generator output with respect to electrical load (to be operated as an ordinary generator).
Misfire detection	The ECM stops supplying fuel to the cylinder with the highest misfiring rate if a misfiring that could damage the catalytic converter is detected.

**DIAGNOSTIC TROUBLE CODE CHART**

M1131151000453

<b>DTC</b>	<b>DIAGNOSTIC ITEMS</b>	<b>REFERENCE PAGE</b>
P0090	Fuel pressure solenoid circuit	<a href="#">P.13A-30</a>
P0101*	Volume airflow circuit range/performance problem	<a href="#">P.13A-38</a>
P0102*	Volume airflow circuit low input	<a href="#">P.13A-45</a>
P0106*	Barometric pressure circuit range/performance problem	<a href="#">P.13A-53</a>
P0107*	Barometric pressure circuit low input	<a href="#">P.13A-59</a>
P0108*	Barometric pressure circuit high input	<a href="#">P.13A-73</a>
P0111*	Intake air temperature circuit range/performance problem	<a href="#">P.13A-83</a>
P0112*	Intake air temperature circuit low input	<a href="#">P.13A-90</a>
P0113*	Intake air temperature circuit high input	<a href="#">P.13A-94</a>
P0116*	Engine coolant temperature circuit range/performance problem	<a href="#">P.13A-101</a>
P0117*	Engine coolant temperature circuit low input	<a href="#">P.13A-111</a>
P0118*	Engine coolant temperature circuit high input	<a href="#">P.13A-115</a>
P0121*	Throttle position sensor circuit range/performance problem	<a href="#">P.13A-123</a>
P0122*	Throttle position sensor circuit low input	<a href="#">P.13A-132</a>
P0123*	Throttle position sensor circuit high input	<a href="#">P.13A-140</a>
P0125*	Insufficient coolant temperature for closed loop fuel control	<a href="#">P.13A-147</a>
P0128	Coolant thermostat (coolant temperature below thermostat regulating temperature)	<a href="#">P.13A-155</a>
P0130	Heated oxygen sensor circuit (sensor 1)	<a href="#">P.13A-156</a>
P0131	Heated oxygen sensor circuit low voltage (sensor 1)	<a href="#">P.13A-170</a>
P0132	Heated oxygen sensor circuit high voltage (sensor 1)	<a href="#">P.13A-176</a>
P0133	Heated oxygen sensor circuit slow response (sensor 1)	<a href="#">P.13A-180</a>
P0134*	Heated oxygen sensor circuit no activity detected (sensor 1)	<a href="#">P.13A-185</a>
P0135	Heated oxygen sensor heater circuit (sensor 1)	<a href="#">P.13A-192</a>
P0136	Heated oxygen sensor circuit (sensor 2)	<a href="#">P.13A-201</a>
P0137	Heated oxygen sensor circuit low voltage (sensor 2)	<a href="#">P.13A-211</a>
P0138	Heated oxygen sensor circuit high voltage (sensor 2)	<a href="#">P.13A-216</a>

<b>DTC</b>	<b>DIAGNOSTIC ITEMS</b>	<b>REFERENCE PAGE</b>
P0139	Heated oxygen sensor circuit slow response (sensor 2)	<a href="#">P.13A-220</a>
P0141	Heated oxygen sensor heater circuit (sensor 2)	<a href="#">P.13A-224</a>
P0171	System too lean	<a href="#">P.13A-232</a>
P0172	System too rich	<a href="#">P.13A-240</a>
P0181	Fuel tank temperature sensor circuit range/performance	<a href="#">P.13A-246</a>
P0182	Fuel tank temperature sensor circuit low input	<a href="#">P.13A-254</a>
P0183	Fuel tank temperature sensor circuit high input	<a href="#">P.13A-259</a>
P0201	Injector circuit-Cylinder 1	<a href="#">P.13A-267</a>
P0202	Injector circuit-Cylinder 2	<a href="#">P.13A-267</a>
P0203	Injector circuit-Cylinder 3	<a href="#">P.13A-267</a>
P0204	Injector circuit-Cylinder 4	<a href="#">P.13A-267</a>
P0234	Turbocharger wastegate system malfunction	<a href="#">P.13A-277</a>
P0243	Turbocharger wastegate solenoid circuit	<a href="#">P.13A-279</a>
P0300	Random/multiple cylinder misfire detected	<a href="#">P.13A-286</a>
P0301	Cylinder 1 misfire detected	<a href="#">P.13A-292</a>
P0302	Cylinder 2 misfire detected	<a href="#">P.13A-292</a>
P0303	Cylinder 3 misfire detected	<a href="#">P.13A-292</a>
P0304	Cylinder 4 misfire detected	<a href="#">P.13A-292</a>
P0325	Knock sensor circuit	<a href="#">P.13A-296</a>
P0335*	Crankshaft position sensor circuit	<a href="#">P.13A-302</a>
P0340*	Camshaft position sensor circuit	<a href="#">P.13A-317</a>
P0401	Exhaust gas recirculation flow insufficient detected	<a href="#">P.13A-328</a>
P0403	Exhaust gas recirculation control circuit	<a href="#">P.13A-330</a>
P0421	Warm up catalyst efficiency below threshold	<a href="#">P.13A-337</a>
P0441	Evaporative emission system incorrect purge flow	<a href="#">P.13A-358</a>
P0442	Evaporative emission system leak detected (Small leak)	<a href="#">P.13A-345</a>
P0443	Evaporative emission system purge control valve circuit	<a href="#">P.13A-363</a>
P0446	Evaporative emission system vent control circuit	<a href="#">P.13A-371</a>
P0451	Evaporative emission system pressure sensor range/performance	<a href="#">P.13A-380</a>
P0452	Evaporative emission system pressure sensor low input	<a href="#">P.13A-397</a>
P0453	Evaporative emission system pressure sensor high input	<a href="#">P.13A-414</a>
P0455	Evaporative emission system leak detected (Gross leak)	<a href="#">P.13A-431</a>
P0456	Evaporative emission system leak detected (Very small leak)	<a href="#">P.13A-447</a>
P0461	Fuel level sensor circuit range/performance (sensor 1)	<a href="#">P.13A-459</a>
P0500	Vehicle speed sensor	<a href="#">P.13A-465</a>
P0506	Idle control system RPM lower than expected	<a href="#">P.13A-477</a>

<b>DTC</b>	<b>DIAGNOSTIC ITEMS</b>	<b>REFERENCE PAGE</b>
P0507	Idle control system RPM higher than expected	<a href="#">P.13A-487</a>
P0513	Immobilizer malfunction	<a href="#">P.13A-496</a>
P0551	Power steering pressure sensor circuit range/performance	<a href="#">P.13A-500</a>
P0554	Power steering pressure sensor circuit intermittent	<a href="#">P.13A-510</a>
P0622	Generator FR terminal circuit malfunction	<a href="#">P.13A-516</a>
P0830	Clutch pedal position switch circuit range/performance	<a href="#">P.13A-523</a>
P1400	Manifold differential pressure sensor circuit malfunction	<a href="#">P.13A-530</a>
P1603*	Battery backup circuit malfunction	<a href="#">P.13A-538</a>
P2066	Fuel level sensor circuit range/performance (sensor 2)	<a href="#">P.13A-523</a>
P2263	Intake charge system malfunction	

*NOTE: Do not replace the engine control module (ECM) until a through terminal check reveals there are no short/open circuits.*

*NOTE: Check that the ECM ground circuit is normal before checking for the cause of the problem.*

*NOTE: After the ECM detects a malfunction, a diagnostic trouble code is recorded the next time the engine is started and the same malfunction is re-detected. However, for items marked with a "\*", the diagnostic trouble code is recorded on the first detection of the malfunction.*

*NOTE: Sensor 1 indicates the sensor mounted at a position closest to the engine, and sensor 2 indicates the sensor mounted at the position second closest to the engine.*

## **SYMPTOM CHART**

M1131151500447

*NOTE: Check that the engine control module (ECM) ground circuit is normal before checking for the cause of the problem.*

<b>SYMPTOMS</b>		<b>INSPECTION PROCEDURE</b>	<b>REFERENCE PAGE</b>
Communication with scan tool is impossible	Communication with all systems is not possible	1	<a href="#">P.13A-551</a>
	Communication with ECM only is not possible	2	<a href="#">P.13A-554</a>
Malfunction Indicator Lamp (SERVICE ENGINE SOON) and related parts	The malfunction indicator lamp (SERVICE ENGINE SOON) does not illuminate right after the ignition switch is turned to the "ON" position	3	<a href="#">P.13A-557</a>
	The malfunction indicator lamp (SERVICE ENGINE SOON) remains illuminated and never goes out	4	<a href="#">P.13A-562</a>
Starting	Cranks, won't start	5	<a href="#">P.13A-565</a>
	Starts up and dies	6	<a href="#">P.13A-570</a>
	Hard starting	7	<a href="#">P.13A-577</a>
Idling stability (improper idling)	Unstable idle (rough idle, hunting)	8	<a href="#">P.13A-582</a>
	Idle speed is high (improper idle speed)	9	<a href="#">P.13A-590</a>
	Idle speed is low (improper idle speed)	10	<a href="#">P.13A-593</a>

SYMPTOMS		INSPECTION PROCEDURE	REFERENCE PAGE
Idling stability (engine stalls)	When the engine is cold, it stalls at idle (die out)	11	<a href="#">P.13A-596</a>
	When the engine is hot, it stalls at idle (die out)	12	<a href="#">P.13A-601</a>
	The engine stalls when accelerating (pass out)	13	<a href="#">P.13A-608</a>
	The engine stalls when decelerating	14	<a href="#">P.13A-610</a>
Driving	Hesitation, sag or stumble	15	<a href="#">P.13A-614</a>
	Acceleration shock	16	<a href="#">P.13A-620</a>
	Deceleration shock	17	<a href="#">P.13A-621</a>
	Poor acceleration	18	<a href="#">P.13A-623</a>
	Surge	19	<a href="#">P.13A-629</a>
	Knocking	20	<a href="#">P.13A-635</a>
Dieseling (Run-on)		21	<a href="#">P.13A-637</a>
Too high CO and HC concentration when idling		22	<a href="#">P.13A-637</a>
IM240 test failure	Transient, mass emission tailpipe test failure	23	<a href="#">P.13A-641</a>
	Purge flow test of the evaporative emission canister failure	24	<a href="#">P.13A-648</a>
	Pressure test of the evaporative system failure	25	<a href="#">P.13A-649</a>
Generator output voltage is low (approximately 12.3 volts)		26	<a href="#">P.13A-651</a>
Improper idle speed when the A/C is on (A/C switch 2 signal)		27	<a href="#">P.13A-655</a>
Radiator fan is inoperative		28	<a href="#">P.13A-657</a>
A/C condensor fan is inoperative		29	<a href="#">P.13A-660</a>
Power supply system and ignition switch-IG system		30	<a href="#">P.13A-663</a>
Fuel pump system		31	<a href="#">P.13A-671</a>
Ignition switch – ST system		32	<a href="#">P.13A-688</a>
Ignition circuit system		33	<a href="#">P.13A-695</a>
A/C system		34	<a href="#">P.13A-703</a>
Charge air cooler water spray system		35	<a href="#">P.13A-706</a>
Charge air cooler water spray lamp system		36	<a href="#">P.13A-718</a>

**PROBLEM SYMPTOMS TABLE (FOR YOUR INFORMATION)**

ITEMS		SYMPTOM
Starting	Won't start	The starter is used to crank the engine, but there is no combustion within the cylinders, and the engine won't start.
	Starts up and dies	The engine starts, but then the engine soon stalls.
	Hard starting	Engine starts after cranking a while.

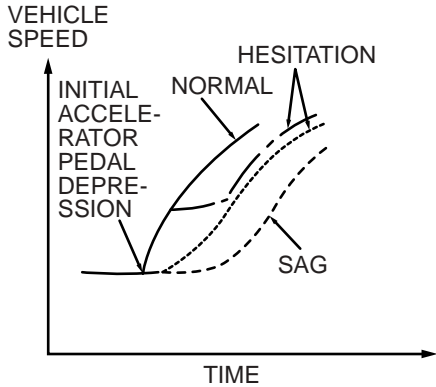
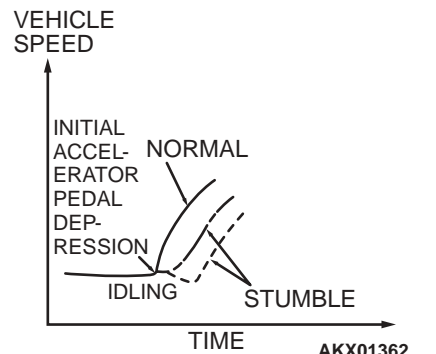
ITEMS		SYMPTOM
Idling stability	Hunting	Engine speed doesn't remain constant; changes at idle.
	Rough idle	Usually, a judgement can be based upon the movement of the tachometer pointer, and the vibration transmitted to the steering wheel, shift lever, body, etc.
	Incorrect idle speed	The engine doesn't idle at the correct speed.
	Engine stall (die out)	The engine stalls when the foot is taken from the accelerator pedal, regardless of whether the vehicle is moving or not.
	Engine stall (pass out)	The engine stalls when the accelerator pedal is depressed.
Driving	Hesitation Sag	<p>" Hesitation " is the delay in response of the vehicle speed (engine speed). This occurs when the accelerator is depressed in order to accelerate from the speed at which the vehicle is now traveling, or a temporary drop in vehicle speed (engine speed) during such acceleration. Serious hesitation is called "sag".</p>  <p align="right">AKX01361AB</p>
	Poor acceleration	Poor acceleration is inability to obtain an acceleration corresponding to the degree of throttle opening, even though acceleration is smooth or the inability to reach maximum speed.
	Stumble	<p>Engine speed increase is delayed when the accelerator pedal is initially depressed for acceleration.</p>  <p align="right">AKX01362</p>
	Shock	The feeling of a comparatively large impact or vibration when the engine is accelerated or decelerated.
	Surge	This is slight acceleration and deceleration feel usually felt during steady, light throttle cruise. Most notable under light loads.
	Knocking	A sharp sound during driving, which sounds like a hammer striking the cylinder walls. It makes poor driveability.
Stopping	Dieseling (run on)	The condition in which the engine continues to run after the ignition switch is turned to the "LOCK" (OFF) position. Also called " dieseling. "

DIAGNOSTIC TROUBLE CODE PROCEDURES

DTC P0090: FUEL PRESSURE SOLENOID CIRCUIT

Fuel Pressure Solenoid Circuit

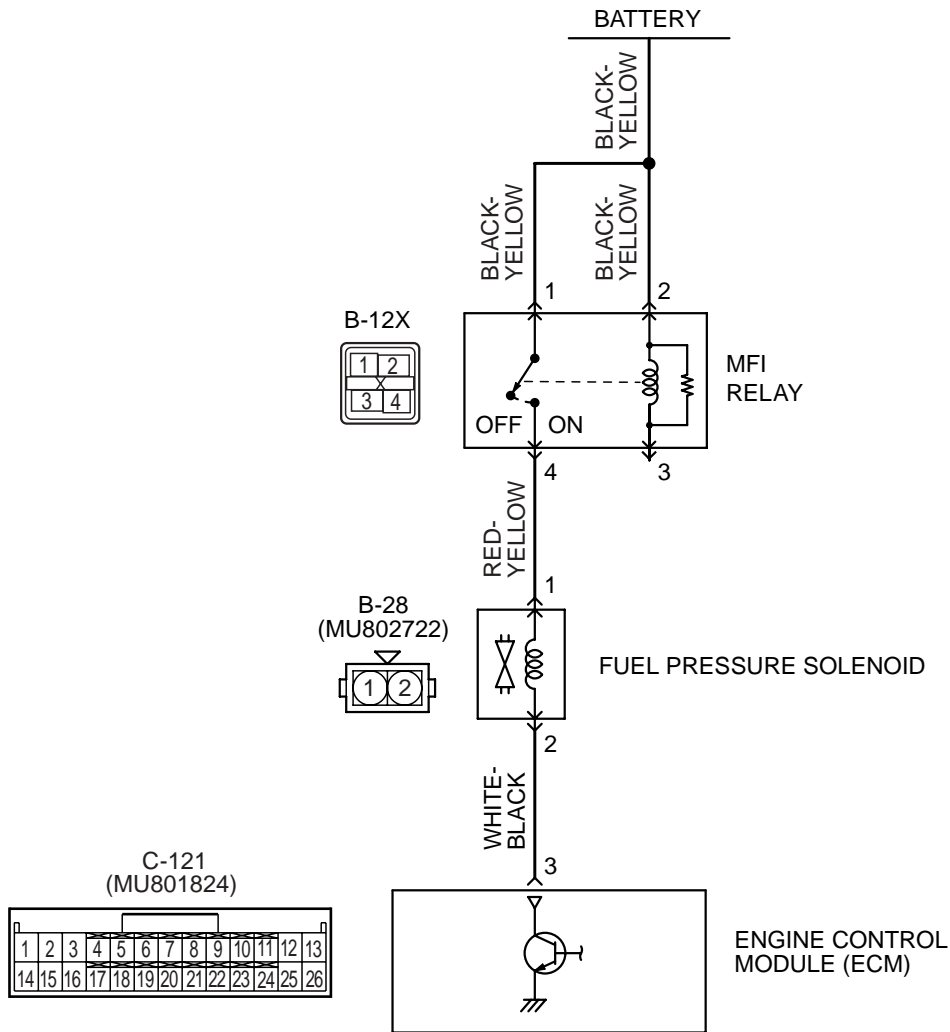

AK203463

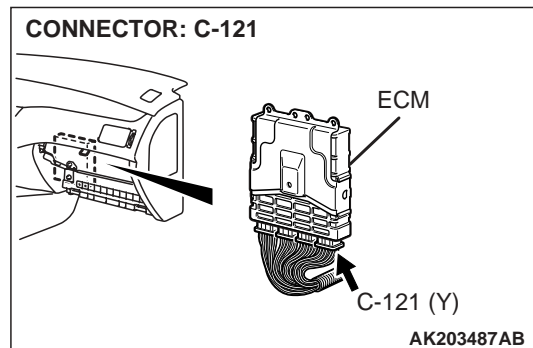
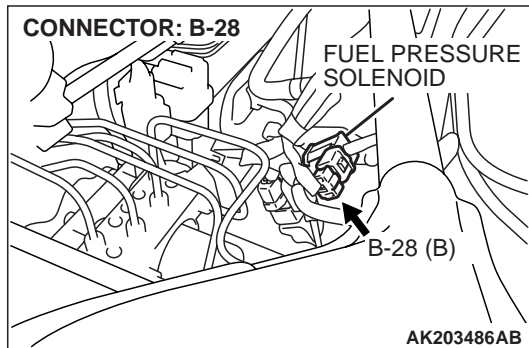

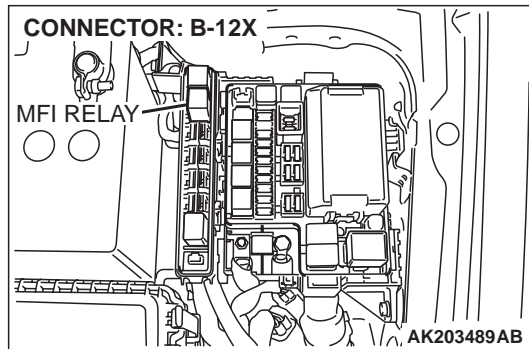

### CIRCUIT OPERATION

- The fuel pressure solenoid power is supplied from the MFI relay (terminal No. 4).
- The ECM controls the fuel pressure solenoid ground by turning the power transistor in the ECM "ON" and "OFF".

### TECHNICAL DESCRIPTION

- To judge if there is open circuit in the fuel pressure solenoid drive circuit, ECM measures the surge voltage of the fuel pressure solenoid coil.
- The ECM drives the fuel pressure solenoid. After the solenoid is turned off, the ECM will check if the solenoid coil produces a surge voltage of 2 volts or more.

### DTC SET CONDITIONS

#### Check Conditions

- Engine is being cranked.
- Battery positive voltage is at between 10 and 16 volts.

### Judgment Criteria

- The fuel pressure solenoid coil surge voltage (battery positive voltage + 2 volts) is not detected for 0.2 second.
- The ECM monitors for this condition once during the drive cycle.

### Check Conditions

- Battery positive voltage is at between 10 and 16 volts.
- Fuel pressure solenoid is ON.
- Turbocharger wastegate solenoid is OFF.
- More than 1 second has elapsed after the above mentioned conditions have been met.

### Judgment Criteria

- The fuel pressure solenoid coil surge voltage (battery positive voltage + 2 volts) is not detected for 1 second. When the fuel pressure solenoid is turned OFF.

### TROUBLESHOOTING HINTS (The most likely causes for this code to be set are:)

- Fuel pressure solenoid failed.
- Open or shorted fuel pressure solenoid circuit, harness damage, or connector damage.
- ECM failed.

## DIAGNOSIS

#### Required Special Tools:

- MB991502: Scan Tool (MUT-II)
- MB991958: Scan Tool (MUT-III Sub Assembly)
  - MB991824: V.C.I.
  - MB991827: USB Cable
  - MB991911: Main Harness B

**STEP 1.** Using scan tool MB991502 or MB991958, check actuator test item 13: fuel pressure solenoid.

**⚠ CAUTION**

To prevent damage to scan tool MB991502 or MB991958, always turn the ignition switch to the "LOCK" (OFF) position before connecting or disconnecting scan tool MB991502 or MB991958.

- (1) Connect scan tool MB991502 or MB991958 to the data link connector.
- (2) Turn the ignition switch to the "ON" position.
- (3) Set scan tool MB991502 or MB991958 to the actuator test mode for item 12, fuel pressure solenoid.
  - An operation sound should be heard and vibration should be felt when the fuel pressure solenoid is operated.
- (4) Turn the ignition switch to the "LOCK" (OFF) position.

**Q: Is the solenoid operating properly?**

**YES :** It can be assumed that this malfunction is intermittent. Refer to GROUP 00, How to Use Troubleshooting/ Inspection Service Points [P.00-6](#).

**NO :** Go to Step 2.

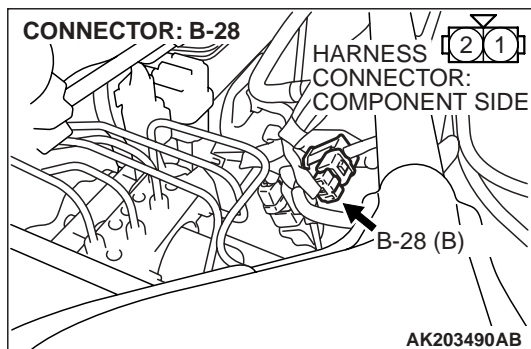
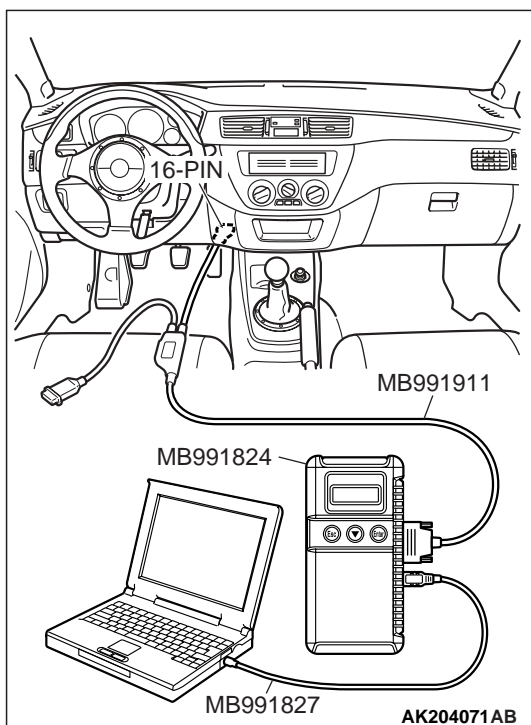
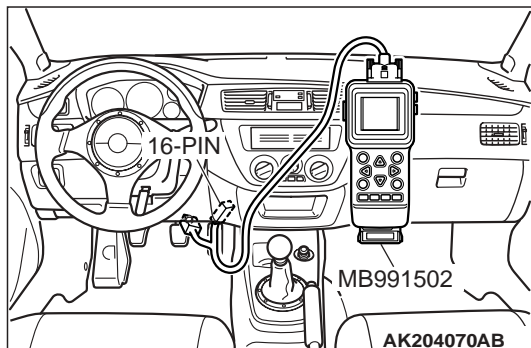

**STEP 2.** Check harness connector B-28 at the fuel pressure solenoid for damage.

**Q: Is the harness connector in good condition?**

**YES :** Go to Step 3.

**NO :** Repair or replace it. Refer to GROUP 00E, Harness Connector Inspection [P.00E-2](#). Then go to Step 12.



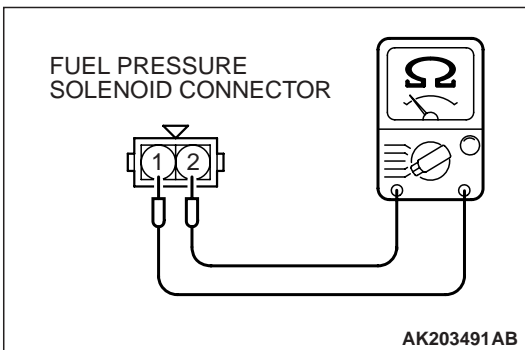
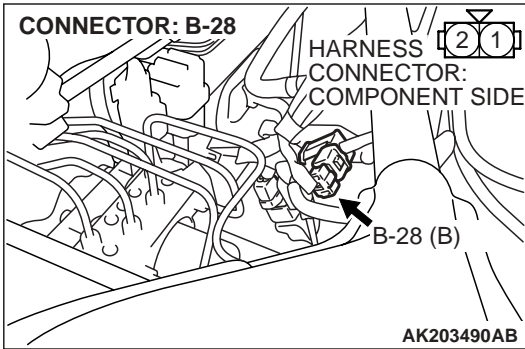

**STEP 3 Check the fuel pressure solenoid.**

(1) Disconnect the fuel pressure solenoid connector B-28.

(2) Measure the resistance between fuel pressure solenoid side connector terminal No. 1 and No. 2.

**Standard value: 29 – 35 ohms [at 20°C (68°F)]**

**Q: Is the resistance between 29 and 35 ohms [at 20°C (68°F)]?**

**YES :** Go to Step 4.

**NO :** Replace the fuel pressure solenoid. Then go to Step 12.

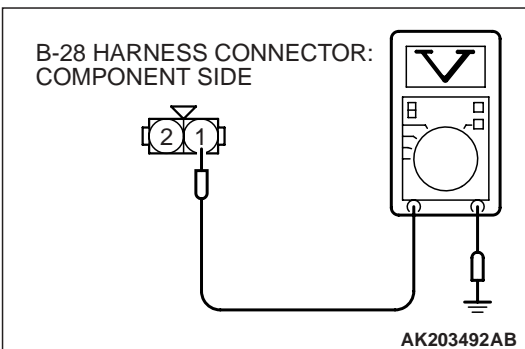
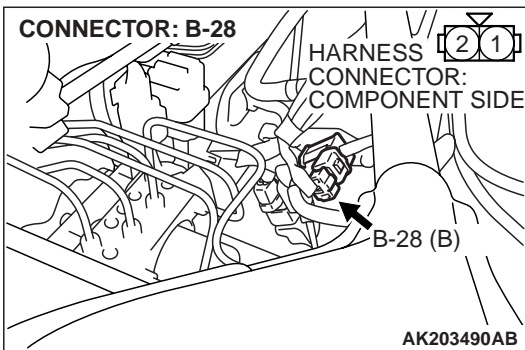

**STEP 4. Measure the power supply voltage at fuel pressure solenoid harness side connector B-28.**

(1) Disconnect connector B-28 and measure at the harness side.

(2) Turn the ignition switch to the "ON" position.

(3) Measure the voltage between terminal No. 1 and ground.

- Voltage should measure battery positive voltage.

(4) Turn the ignition switch to the "LOCK" (OFF) position.

**Q: Is battery positive voltage (approximately 12 volts) present?**

**YES :** Go to Step 6.

**NO :** Go to Step 5.

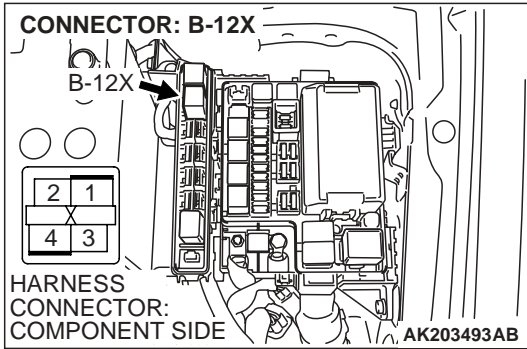

**STEP 5. Check harness connector B-12X at MFI relay for damage.**

**Q: Is the harness connector in good condition?**

- YES :** Repair harness wire between MFI relay connector B-12X (terminal No. 4) and fuel pressure solenoid connector B-101 (terminal No. 1) because of open circuit or short circuit to ground. Then go to Step 12.
- NO :** Repair or replace it. Refer to GROUP 00E, Harness Connector Inspection P.00E-2. Then go to Step 12.

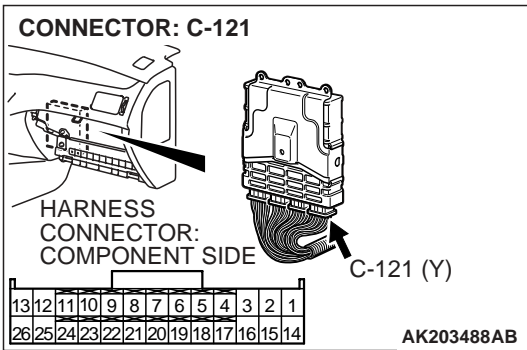

**STEP 6. Measure the power supply voltage at ECM connector C-121 by backprobing.**

- (1) Do not disconnect connector C-121.
- (2) Turn the ignition switch to the "ON" position.

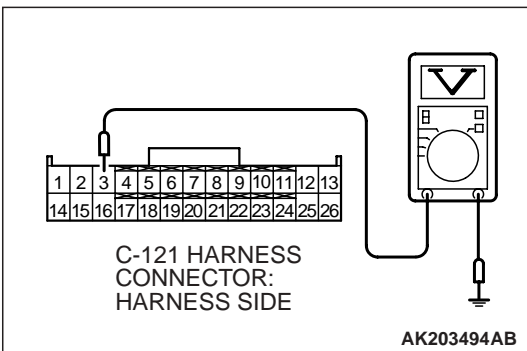

- (3) Measure the voltage between terminal No. 3 and ground by backprobing.
  - Voltage should measure battery positive voltage.
- (4) Turn the ignition switch to the "LOCK" (OFF) position.

**Q: Is battery positive voltage (approximately 12 volts) present?**

- YES :** Go to Step 9.
- NO :** Go to Step 7.

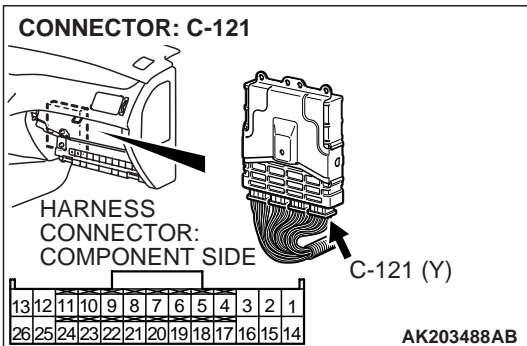

**STEP 7. Check harness connector C-121 at ECM for damage.**

**Q: Is the harness connector in good condition?**

- YES :** Go to Step 8.
- NO :** Repair or replace it. Refer to GROUP 00E, Harness Connector Inspection P.00E-2. Then go to Step 12.

**STEP 8. Check for open circuit and short circuit to ground between fuel pressure solenoid connector B-28 (terminal No. 2) and ECM connector C-121 (terminal No. 3).**

**Q: Is the harness wire in good condition?**

- YES :** Replace the ECM. Then go to Step 12.
- NO :** Repair it. Then go to Step 12.

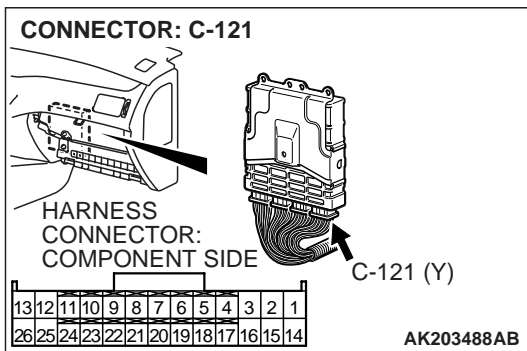
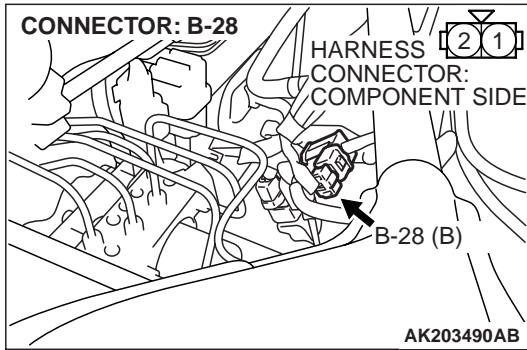

**STEP 9. Check harness connector C-121 at ECM for damage.**

**Q: Is the harness connector in good condition?**

- YES :** Go to Step 10.
- NO :** Repair or replace it. Refer to GROUP 00E, Harness Connector Inspection P.00E-2. Then go to Step 12.

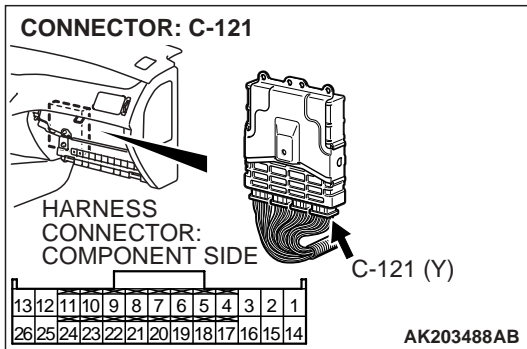

**STEP 10. Check for harness damage between MFI relay connector B-12X (terminal No. 4) and fuel pressure solenoid connector B-28 (terminal No. 1).**

**Q: Is the harness wire in good condition?**

**YES :** Go to Step 11.

**NO :** Repair it. Then go to Step 12.

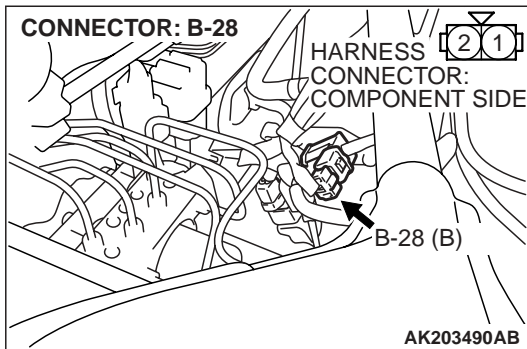
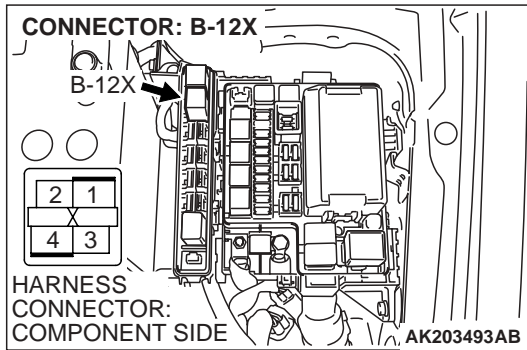

**STEP 11. Check for harness damage between fuel pressure solenoid connector B-28 (terminal No. 2) and ECM connector C-121 (terminal No. 3).**

**Q: Is the harness wire in good condition?**

**YES :** Replace the ECM. Then go to Step 12.

**NO :** Repair it. Then go to Step 12.

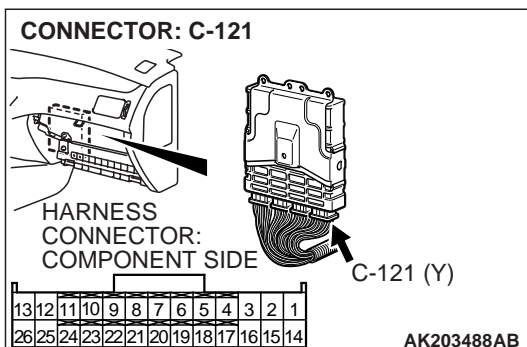
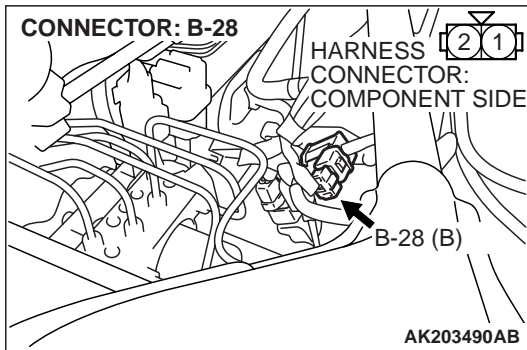

**STEP 12. Perform the OBD-II drive cycle.**

- (1) Carry out a test drive with the drive cycle pattern. Refer to GROUP 13A, Diagnostic Function – OBD-II Drive Cycle – Procedure 6 – Other Monitor [P.13A-6](#).
- (2) Check the diagnostic trouble code (DTC).

**Q: Is DTC P0090 set?**

**YES** : Repeat the troubleshooting.

**NO** : The procedure is complete.

DTC P0101: VOLUME AIRFLOW CIRCUIT RANGE/PERFORMANCE PLOBLEM

Volume Airflow Sensor Circuit

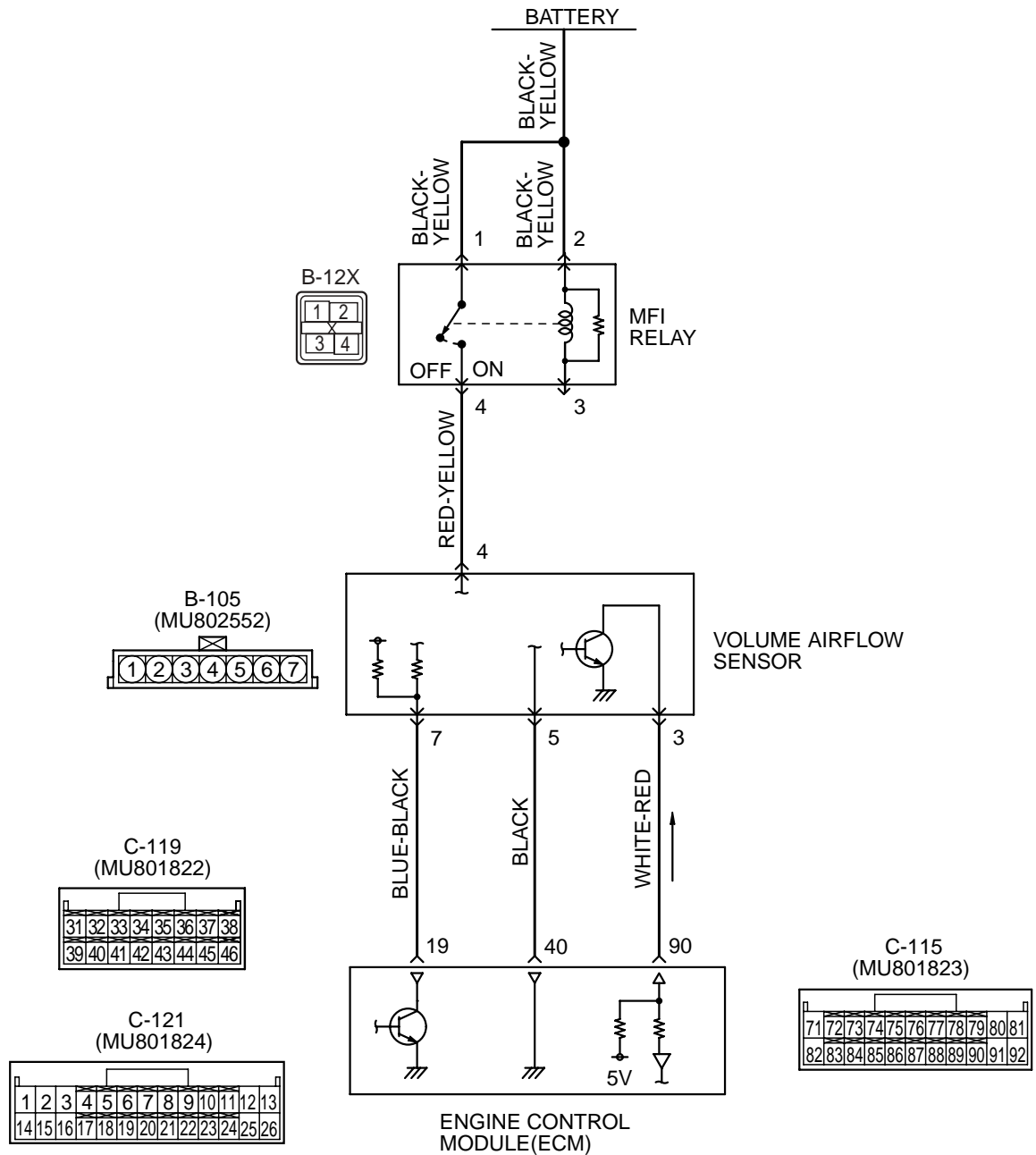

AK203464

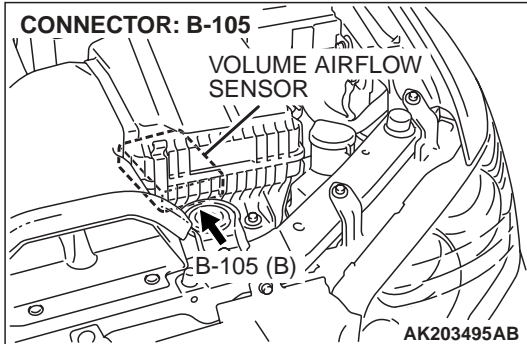
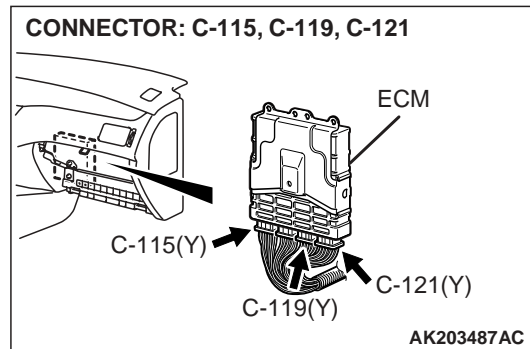
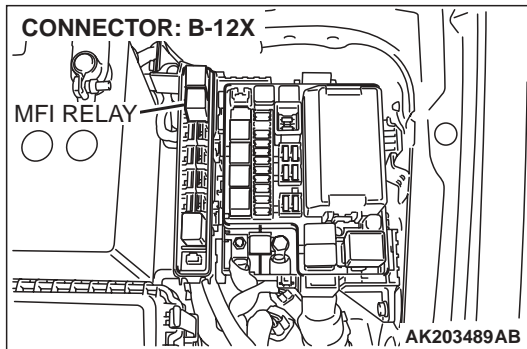

### CIRCUIT OPERATION

- The volume airflow sensor power is supplied from the MFI relay (terminal No. 4), and the ground is provided on the ECM (terminal No. 40).
- 5-volt power is applied to the volume airflow sensor output terminal (terminal No. 3) from the ECM (terminal No. 90). The volume airflow sensor generates a pulse signal when the output terminal and ground are opened/closed (opened/short).
- The volume airflow reset signal is input by the ECM (terminal No. 19) to the volume airflow sensor (terminal No. 7).

### TECHNICAL DESCRIPTION

- While the engine is running, the volume airflow sensor outputs a pulse signal which corresponds to the volume of airflow.
- The ECM checks whether the frequency of this signal output by the volume airflow sensor while the engine is running is at or above the set value.
- When the throttle position sensor output voltage is low, the ECM causes the power transistor to be "ON" to send an airflow sensor reset signal to the airflow sensor. In response to the reset signal, the airflow sensor resets the filter circuit and improves the ability of the airflow sensor to measure the amount of air in a small air intake region.

### DTC SET CONDITIONS

#### Check Conditions

- Throttle position sensor output voltage is 1.5 volts or higher.
- Engine speed is higher than 2,000 r/min.

#### Judgement Criteria

- Volume airflow sensor output frequency has continued to be 60 Hz or lower for 2 seconds.

#### Check Conditions

- Throttle position sensor output voltage is 2 volts or lower.
- Engine speed is lower than 2,000 r/min.

#### Judgement Criteria

- Volume airflow sensor output frequency has continued to be 1,000 Hz or higher for 2 seconds.

### TROUBLESHOOTING HINTS (The most likely causes for this code to be set are:)

- Volume airflow sensor failed.
- Open or shorted volume airflow sensor circuit, harness damage, or connector damage.
- ECM failed.
- Air leak between volume airflow sensor and throttle body.

## DIAGNOSIS

### Required Special Tools:

- MB991502: Scan Tool (MUT-II)
- MB991958: Scan Tool (MUT-III Sub Assembly)
  - MB991824: V.C.I.
  - MB991827: USB Cable
  - MB991911: Main Harness B

**STEP 1. Using scan tool MB991502 or MB991958, check data list item 12: Volume Airflow Sensor.**

#### **⚠ CAUTION**

To prevent damage to scan tool MB991502 or MB991958, always turn the ignition switch to the "LOCK" (OFF) position before connecting or disconnecting scan tool MB991502 or MB991958.

- (1) Connect scan tool MB991502 or MB991958 to the data link connector.
- (2) Start the engine and run at idle.
- (3) Set scan tool MB991502 or MB991958 to the data reading mode for item 12, Volume Airflow Sensor.
- (4) Warm up the engine to normal operating temperature: 80°C to 95°C (176°F to 203°F).
  - The standard value during idling should be 10 Hz or more.
  - When the engine is revved, the frequency should increase according to the increase in engine speed.
- (5) Turn the ignition switch to the "LOCK" (OFF) position.

#### **Q: Is the sensor operating properly?**

**YES :** It can be assumed that this malfunction is intermittent. Refer to GROUP 00, How to Use Troubleshooting/ Inspection Service Points [P.00-6](#).

**NO :** Go to Step 2.

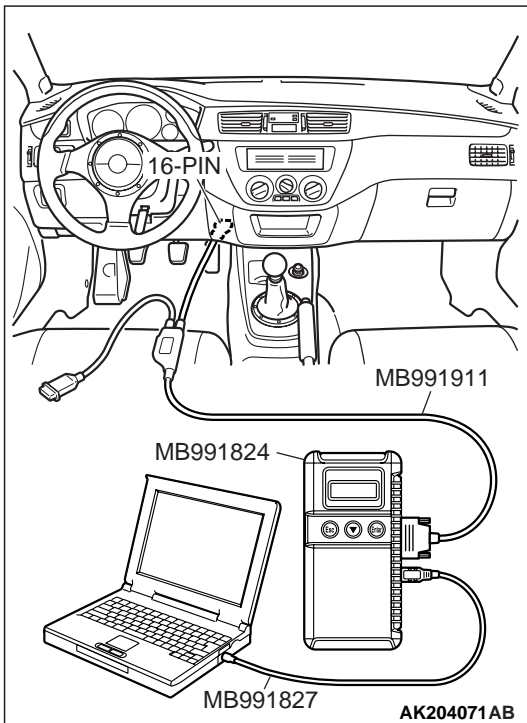
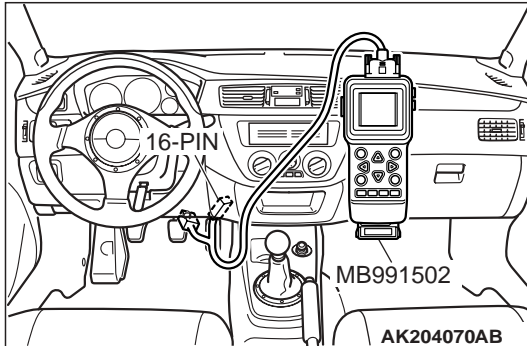



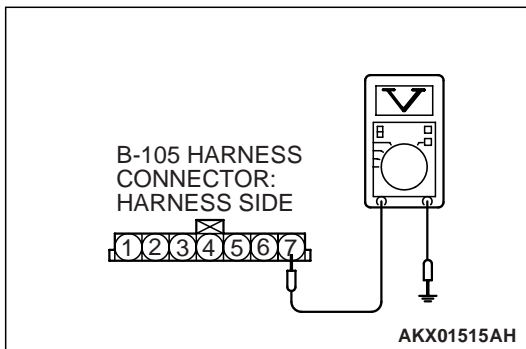
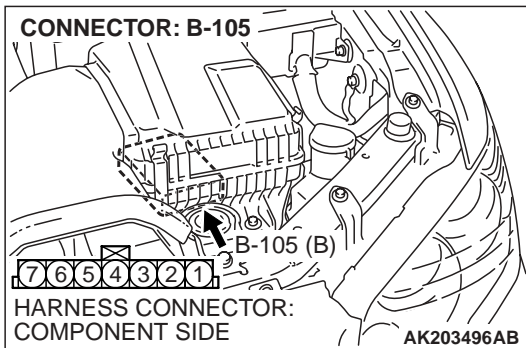

**STEP 2. Measure the reset signal voltage at volume airflow sensor connector B-105 by backprobing.**

- (1) Do not disconnect connector B-105.
- (2) Turn the ignition switch to the "ON" position.

- (3) Measure the voltage between terminal No. 7 and ground by backprobing.

- Voltage should measure between 6.0 and 9.0 volts.

- (4) Turn the ignition switch to the "LOCK" (OFF) position.

**Q: Is the measured voltage between 6.0 and 9.0 volts?**

- YES :** Go to Step 5.  
**NO :** Go to Step 3.

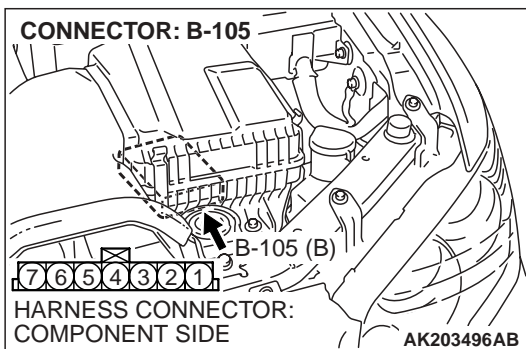

**STEP 3. Check connector B-105 at volume airflow sensor and connector C-121 at ECM for damage.**

**Q: Is the connector in good condition?**

- YES :** Go to Step 4.  
**NO :** Repair or replace it. Refer to GROUP 00E, Harness Connector Inspection [P.00E-2](#). Then go to Step 9.

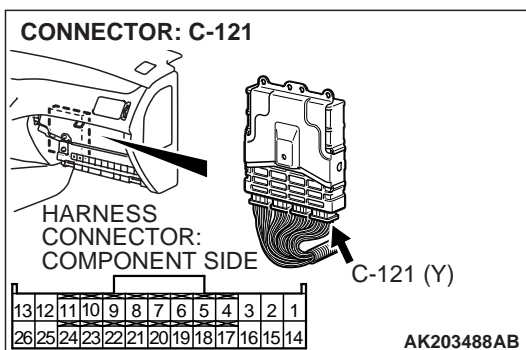

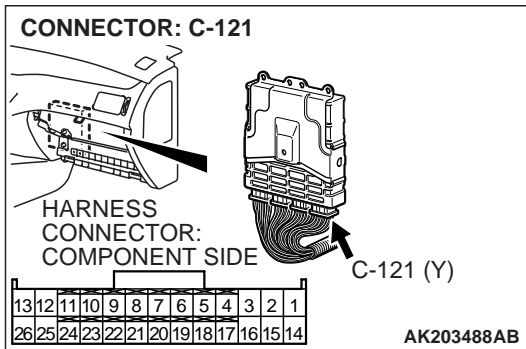
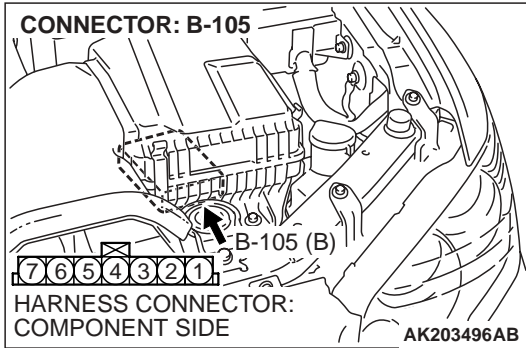

**STEP 4. Check for short circuit to ground between volume airflow sensor connector B-105 (terminal No. 7) and ECM connector C-121 (terminal No. 19).**

**Q: Is the harness wire in good condition?**

**YES :** Replace the volume airflow sensor. Then go to Step 9.

**NO :** Repair it. Then go to Step 9.

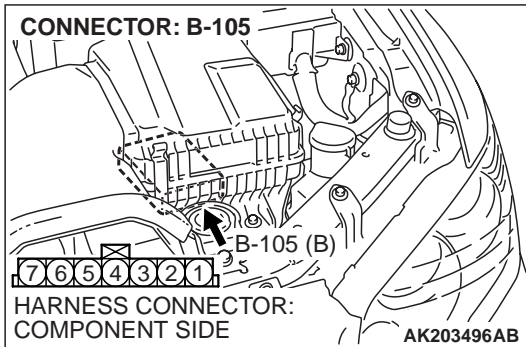

**STEP 5. Measure the reset signal voltage at volume airflow sensor connector B-105 by backprobing.**

(1) Do not disconnect connector B-105.

(2) Start the engine and run at idle.

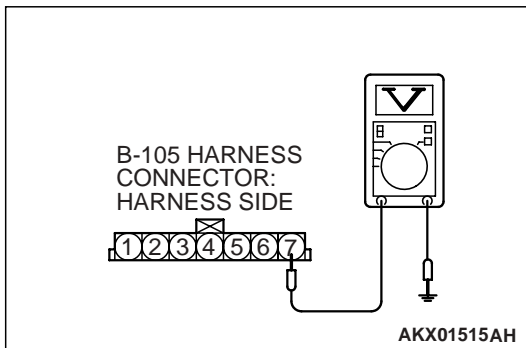

(3) Measure the voltage between terminal No. 7 and ground by backprobing.

- When the engine idling, voltage should measure 1.0 volt or less.
- When the engine speed is 3,000 r/min, voltage should measure between 6.0 and 9.0 volts.

(4) Turn the ignition switch to the "LOCK" (OFF) position.

**Q: Is the measured voltage within the specified range?**

**YES :** Go to Step 8.

**NO :** Go to Step 6.

**STEP 6. Check harness connector B-105 at volume airflow sensor and harness connector C-121 at ECM for damage.**

**Q: Is the harness connector in good condition?**

**YES :** Go to Step 7.

**NO :** Repair or replace it. Refer to GROUP 00E, Harness Connector Inspection [P.00E-2](#). Then go to Step 9.

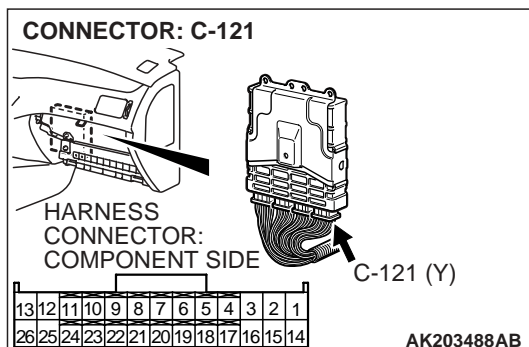
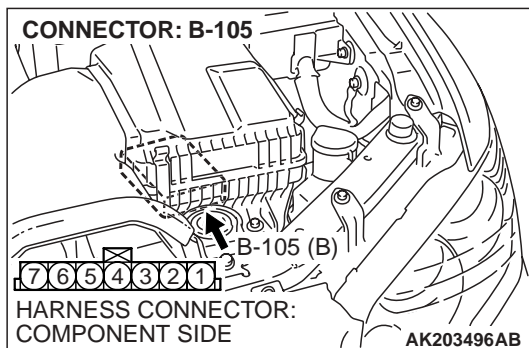

**STEP 7. Check for open circuit and harness damage between volume airflow sensor connector B-105 (terminal No. 7) and ECM connector C-121 (terminal No. 19).**

**Q: Is the harness wire in good condition?**

**YES :** Replace the ECM. Then go to Step 9.

**NO :** Repair it. Then go to Step 9.

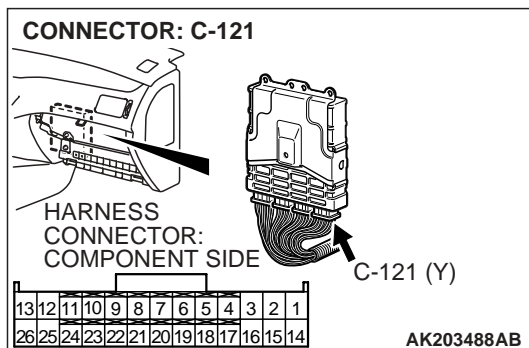
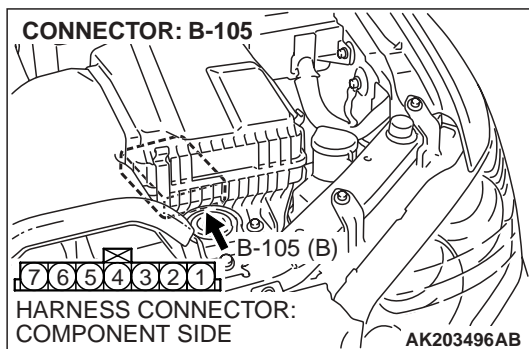

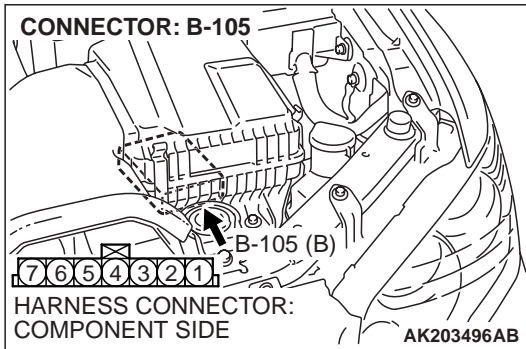
**STEP 8. Replace the volume airflow sensor.**

- (1) Replace the volume airflow sensor.
- (2) Carry out a test drive with the drive cycle pattern. Refer to GROUP 13A, Diagnostic Function – OBD-II Drive Cycle – Procedure 6 – Other Monitor [P.13A-6](#).
- (3) Check the diagnostic trouble code (DTC).

**Q: Is DTC P0101 set?**

**YES** : Replace the ECM. Then go to Step 9.

**NO** : The procedure is complete.

**STEP 9. Perform the OBD-II drive cycle.**

- (1) Carry out a test drive with the drive cycle pattern. Refer to GROUP 13A, Diagnostic Function – OBD-II Drive Cycle – Procedure 6 – Other Monitor [P.13A-6](#).
- (2) Check the diagnostic trouble code (DTC).

**Q: Is DTC P0101 set?**

**YES** : Repeat the troubleshooting.

**NO** : The procedure is complete.

DTC P0102: VOLUME AIRFLOW CIRCUIT LOW INPUT

Volume Airflow Sensor Circuit

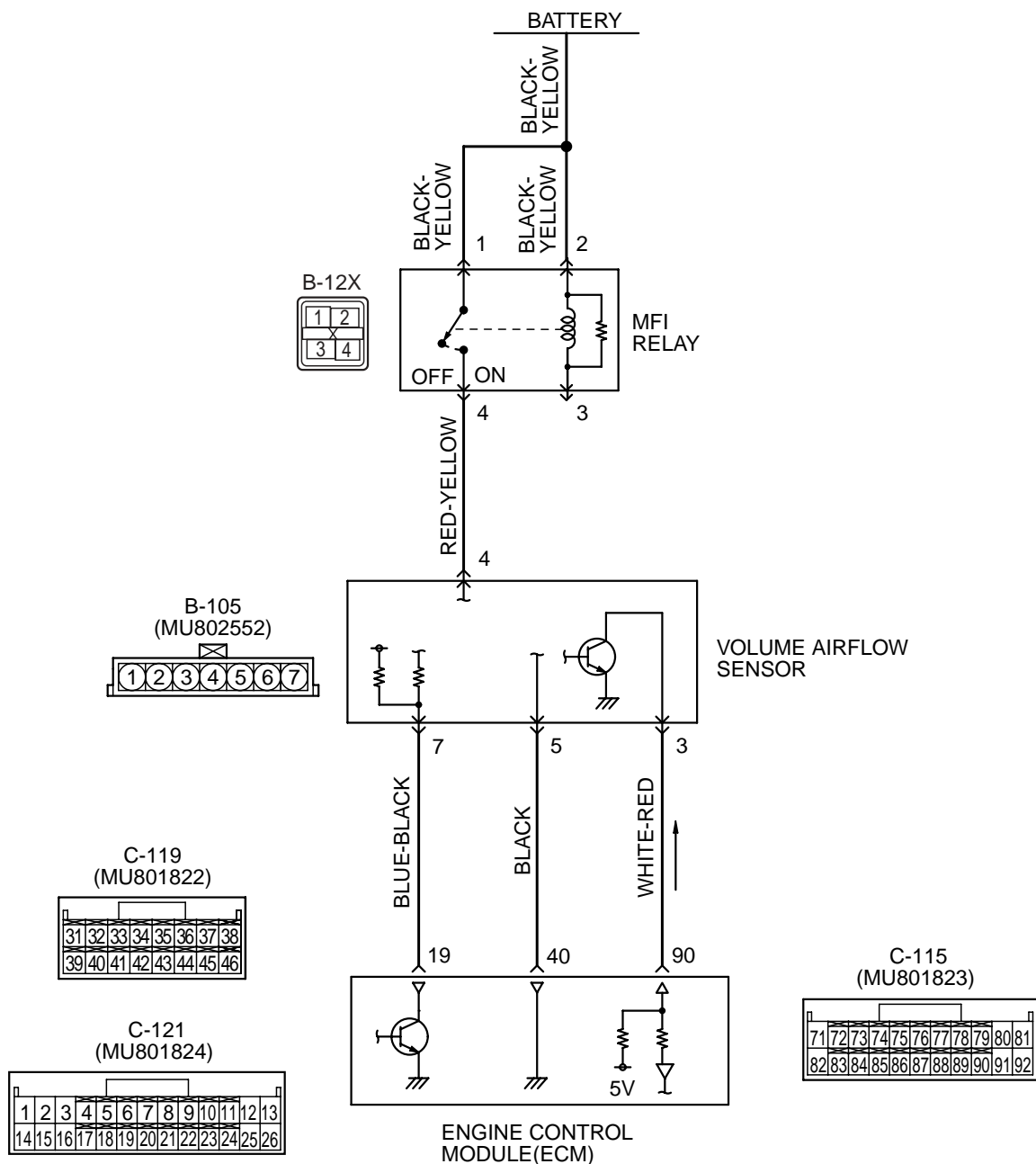

AK203464

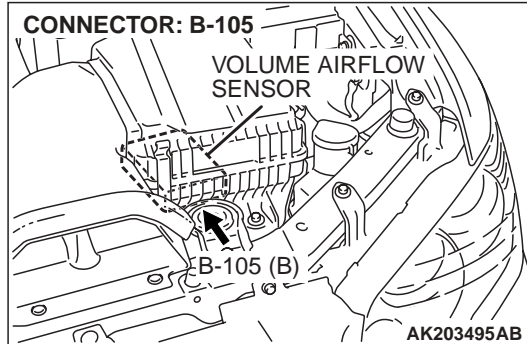
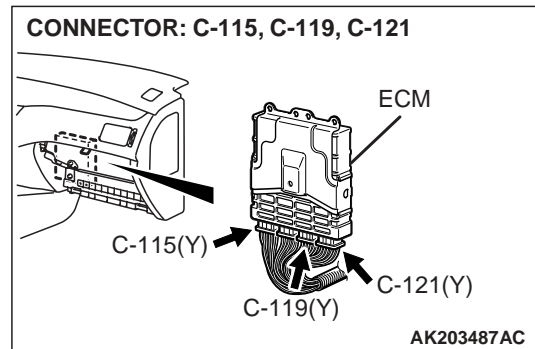
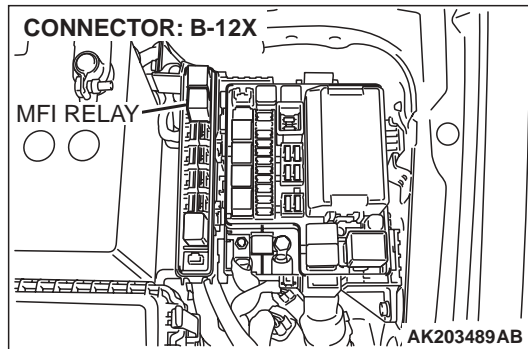

### CIRCUIT OPERATION

- The volume airflow sensor power is supplied from the MFI relay (terminal No. 4), and the ground is provided on the ECM (terminal No. 40).
- 5-volt power is applied to the volume airflow sensor output terminal (terminal No. 3) from the ECM (terminal No. 90). The volume airflow sensor generates a pulse signal when the output terminal and ground are opened/closed (opened/short).

### TECHNICAL DESCRIPTION

- While the engine is running, the volume airflow sensor outputs a pulse signal which corresponds to the volume of airflow.
- The ECM checks whether the frequency of this signal output by the volume airflow sensor while the engine is running is at or above the set value.

### DTC SET CONDITIONS

#### Check Conditions

- Engine speed is higher than 500 r/min.

#### Judgement Criteria

- Volume airflow sensor output frequency has continued to be 3.3 Hz or lower for 2 seconds.

### TROUBLESHOOTING HINTS (The most likely causes for this code to be set are:)

- Volume airflow sensor failed.
- Open or shorted volume airflow sensor circuit, harness damage or connector damage.
- ECM failed.

## DIAGNOSIS

#### Required Special Tools:

- MB991502: Scan Tool (MUT-II)
- MB991958: Scan Tool (MUT-III Sub Assembly)
  - MB991824: V.C.I.
  - MB991827: USB Cable
  - MB991911: Main Harness B

**STEP 1.** Using scan tool MB991502 or MB991958, check data list item 12: Volume Airflow Sensor.

**⚠ CAUTION**

To prevent damage to scan tool MB991502 or MB991958, always turn the ignition switch to the "LOCK" (OFF) position before connecting or disconnecting scan tool MB991502 or MB991958.

- (1) Connect scan tool MB991502 or MB991958 to the data link connector.
- (2) Start the engine and run at idle.
- (3) Set scan tool MB991502 or MB991958 to the data reading mode for item 12, Volume Airflow Sensor.
- (4) Warm up the engine to normal operating temperature: 80°C to 95°C (176°F to 203°F).

- The standard value during idling should be 10 Hz or more.
- When the engine is revved, the frequency should increase according to the increase in engine speed.

- (5) Turn the ignition switch to the "LOCK" (OFF) position.

**Q: Is the sensor operating properly?**

**YES :** It can be assumed that this malfunction is intermittent. Refer to GROUP 00, How to Use Troubleshooting/ Inspection Service Points [P.00-6](#).

**NO :** Go to Step 2.

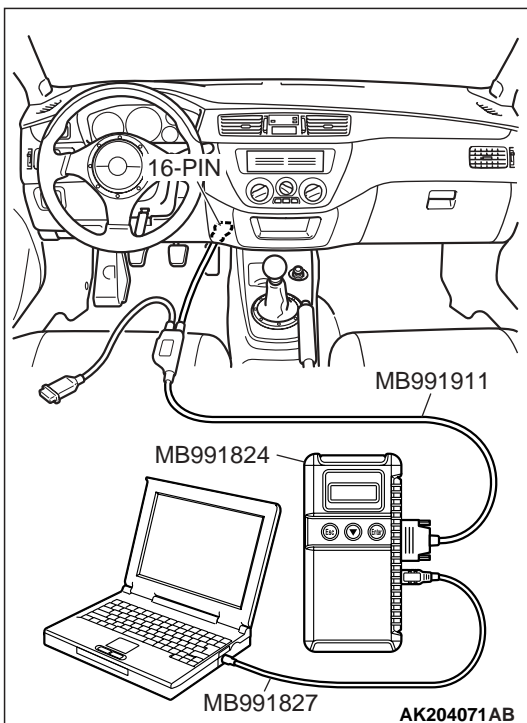
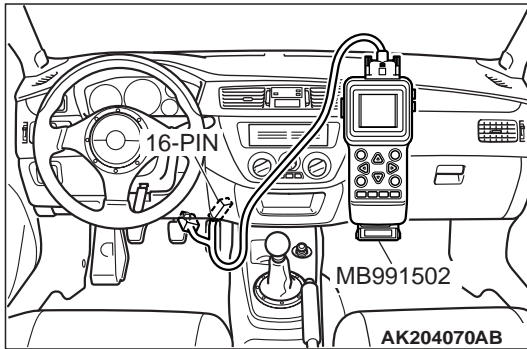

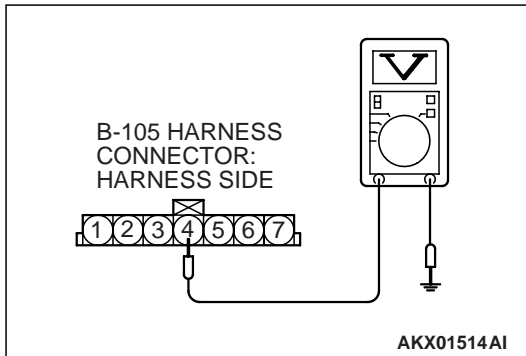
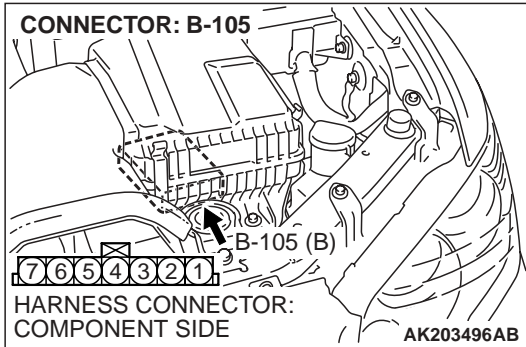

**STEP 2. Measure the power supply voltage at volume airflow sensor connector B-105 by backprobing.**

- (1) Do not disconnect connector B-105.
- (2) Turn the ignition switch to the "ON" position.

- (3) Measure the voltage between terminal No. 4 and ground by backprobing.

- Voltage should measure battery positive voltage.

- (4) Turn the ignition switch to the "LOCK" (OFF) position.

**Q: Is battery positive voltage (approximately 12 volts) present?**

**YES :** Go to Step 5.

**NO :** Go to Step 3.

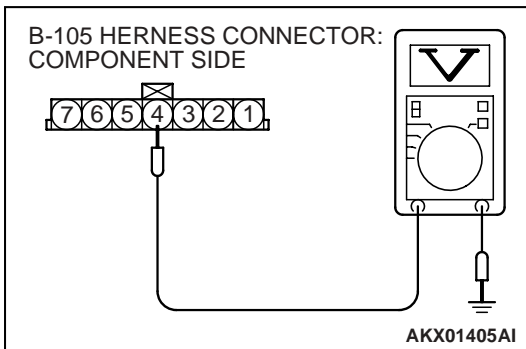
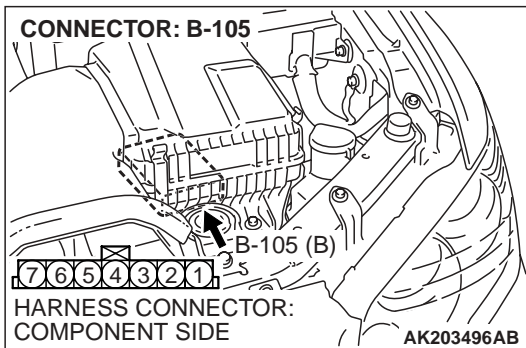

**STEP 3. Measure the power supply voltage at volume airflow sensor harness side connector B-105.**

- (1) Disconnect connector B-105 and measure at the harness side.

- (2) Turn the ignition switch to the "ON" position.

- (3) Measure the voltage between terminal No. 4 and ground.

- Voltage should measure battery positive voltage.

- (4) Turn the ignition switch to the "LOCK" (OFF) position.

**Q: Is battery positive voltage (approximately 12 volts) present?**

**YES :** Go to Step 4.

**NO :** Repair harness wire between MFI relay connector B-12X (terminal No. 4) and volume airflow sensor connector B-105 (terminal No. 4) because of open circuit or short circuit to ground. Then go to Step 13.



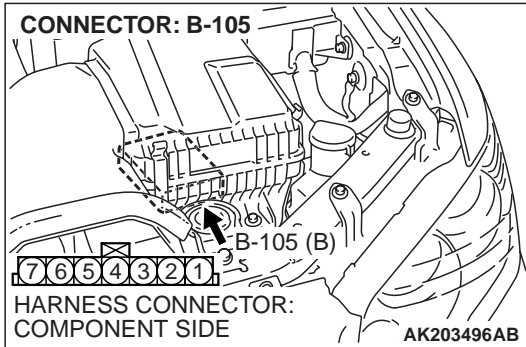

**STEP 4. Check connector B-105 at the volume airflow sensor for damage.**

**Q: Is the connector in good condition?**

**YES :** Repair harness wire between MFI relay connector B-12X (terminal No. 4) and volume airflow sensor connector B-105 (terminal No. 4) because of harness damage. Then go to Step 13.

**NO :** Repair or replace it. Refer to GROUP 00E, Harness Connector Inspection [P.00E-2](#). Then go to Step 13.

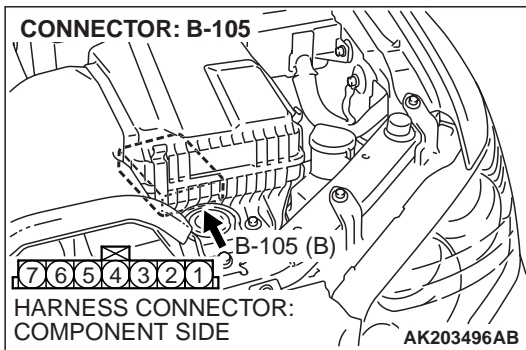

**STEP 5. Check connector B-105 at volume airflow sensor for damage.**

**Q: Is the connector in good condition?**

**YES :** Go to Step 6.

**NO :** Repair or replace it. Refer to GROUP 00E, Harness Connector Inspection [P.00E-2](#). Then go to Step 13.

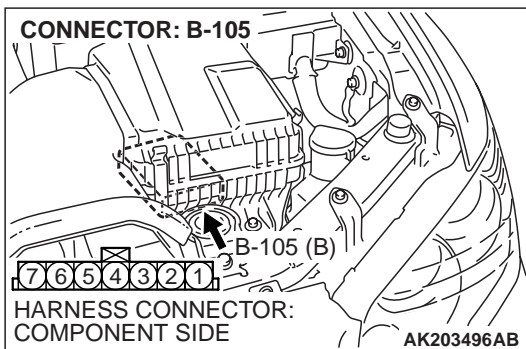

**STEP 6. Measure the sensor supply voltage at volume airflow sensor harness side connector B-105.**

(1) Disconnect connector B-105 and measure at the harness side.

(2) Turn the ignition switch to the "ON" position.

(3) Measure the voltage between terminal No. 3 and ground.

- Voltage should measure between 4.8 and 5.2 volts.

(4) Turn the ignition switch to the "LOCK" (OFF) position.

**Q: Is the measured voltage between 4.8 and 5.2 volts?**

**YES :** Go to Step 9.

**NO :** Go to Step 7.

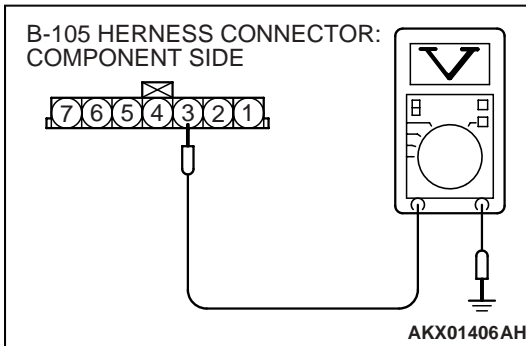

**STEP 7. Check harness connector C-115 at ECM for damage.**

**Q: Is the harness connector in good condition?**

**YES :** Go to Step 8.

**NO :** Repair or replace it. Refer to GROUP 00E, Harness Connector Inspection [P.00E-2](#). Then go to Step 13.

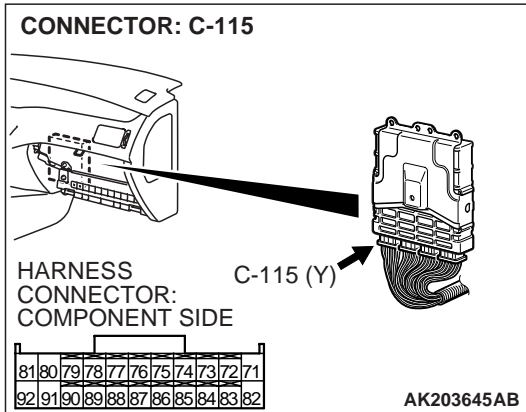

**STEP 8. Check for short circuit to ground between volume airflow sensor connector B-105 (terminal No. 3) and ECM connector C-115 (terminal No. 90).**

**Q: Is the harness wire in good condition?**

**YES :** Replace the ECM. Then go to Step 13.

**NO :** Repair it. Then go to Step 13.

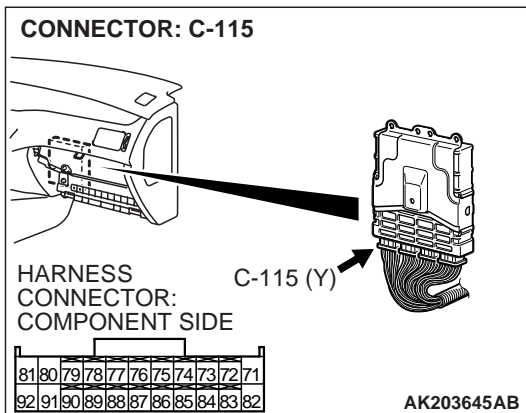
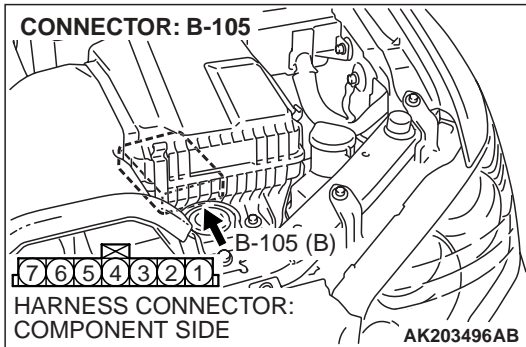

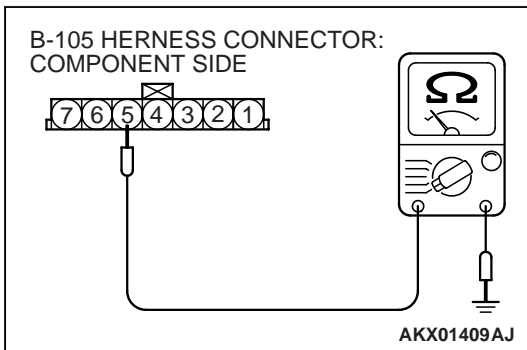
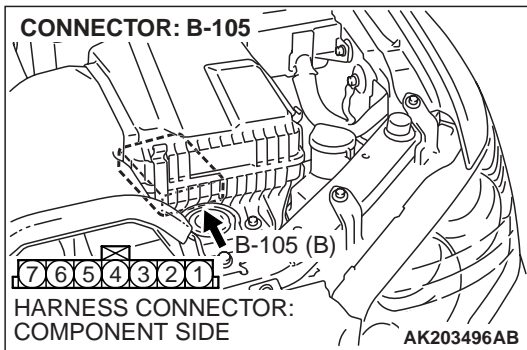

**STEP 9. Check for continuity at volume airflow sensor harness side connector B-105.**

(1) Disconnect connector B-105 and measure at the harness side.

(2) Check for the continuity between terminal No. 5 and ground.

- Should be less than 2 ohms.

**Q: Does continuity exist?**

**YES :** Go to Step 12.

**NO :** Go to Step 10.

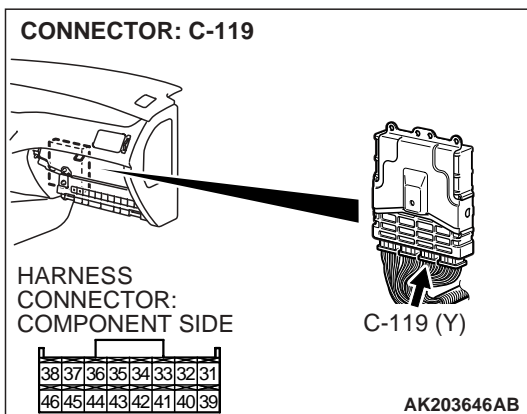

**STEP 10. Check harness connector C-119 at ECM for damage.**

**Q: Is the harness connector in good condition?**

**YES :** Go to Step 11.

**NO :** Repair or replace it. Refer to GROUP 00E, Harness Connector Inspection [P.00E-2](#). Then go to Step 13.

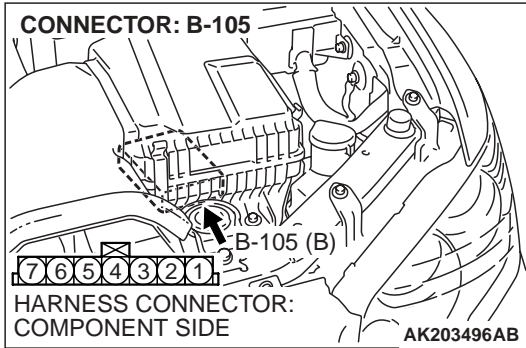

**STEP 11. Check for open circuit and harness damage between volume airflow sensor connector B-105 (terminal No. 5) and ECM connector C-119 (terminal No. 40).**

**Q: Is the harness wire in good condition?**

- YES :** Replace the ECM. Then go to Step 13.
- NO :** Repair it. Then go to Step 13.

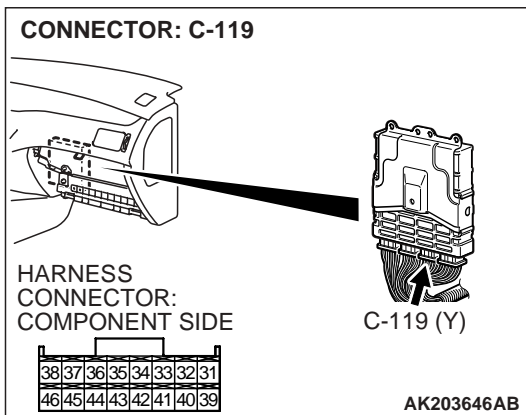

**STEP 12. Check harness connector C-119 at ECM for damage.**

**Q: Is the harness connector in good condition?**

- YES :** Replace the volume airflow sensor. Then go to Step 13.
- NO :** Repair or replace it. Refer to GROUP 00E, Harness Connector Inspection [P.00E-2](#). Then go to Step 13.

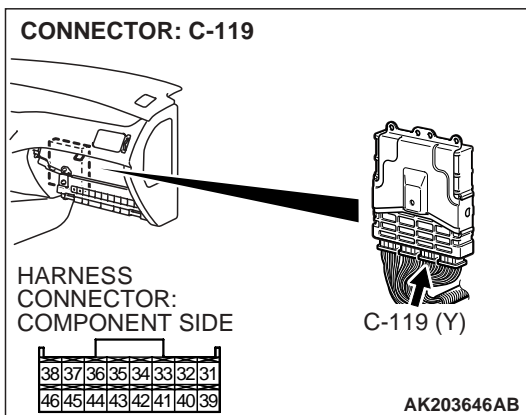

**STEP 13. Perform the OBD-II drive cycle.**

- (1) Carry out a test drive with the drive cycle pattern. Refer to GROUP 13A, Diagnostic Function – OBD-II Drive Cycle – Procedure 6 – Other Monitor [P.13A-6](#).
- (2) Check the diagnostic trouble code (DTC).

**Q: Is DTC P0102 set?**

- YES :** Repeat the troubleshooting.
- NO :** The procedure is complete.

DTC P0106: BAROMETRIC PRESSURE CIRCUIT RANGE/PERFORMANCE PROBLEM

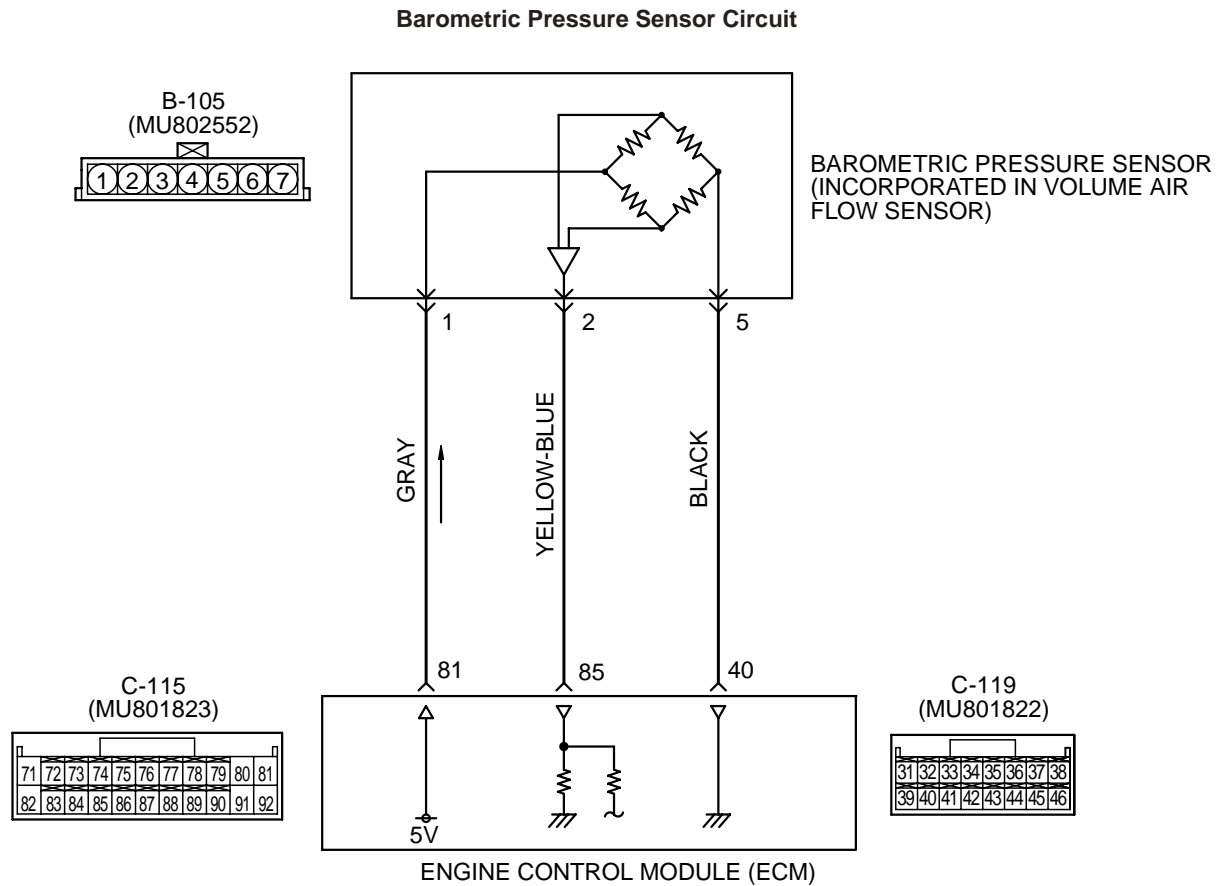

AK203497

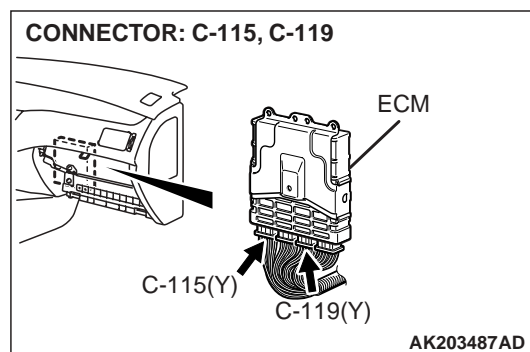
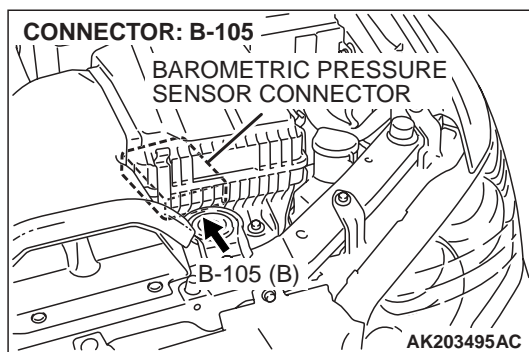

**CIRCUIT OPERATION**

- A 5-volt voltage is supplied to the barometric pressure sensor power terminal (terminal No. 1) from the ECM (terminal No. 81). The ground terminal (terminal No. 5) is grounded with ECM (terminal No. 40).
- A voltage that is proportional to the atmospheric pressure is sent to the ECM (terminal No. 85) from the barometric pressure sensor output terminal (terminal No. 2).

**TECHNICAL DESCRIPTION**

- The barometric pressure sensor outputs a voltage which corresponds to the barometric pressure.
- The ECM checks whether this voltage is within a specified range.

**DTC SET CONDITIONS****Check Conditions**

- Barometric pressure is lower than 76 kPa (11 psi).

**Judgement Criteria**

- During 15 times of driving, the changes in the sensor output voltage should measure 0.015 volt [equivalent to 0.4 kPa (0.06 psi)] or less.

- Make sure that the engine coolant temperature is 72°C (160°F) or higher during each of the 15 times of driving. Also, during each of the 15 times of driving, make sure that after the engine has been started, the engine coolant temperature has increased for 23°C (40°F) or higher.

**TROUBLESHOOTING HINTS (The most likely causes for this code to be set are:)**

- Barometric pressure sensor failed.
- Open or shorted barometric pressure sensor circuit, harness damage, or connector damage.
- ECM failed.

## DIAGNOSIS

### Required Special Tools:

- MB991502: Scan Tool (MUT-II)
- MB991958: Scan Tool (MUT-III Sub Assembly)
  - MB991824: V.C.I.
  - MB991827: USB Cable
  - MB991911: Main Harness B

**STEP 1. Using scan tool MB991502 or MB991958, read the diagnostic trouble code (DTC).**

#### **⚠ CAUTION**

To prevent damage to scan tool MB991502 or MB991958, always turn the ignition switch to the "LOCK" (OFF) position before connecting or disconnecting scan tool MB991502 or MB991958.

- (1) Connect scan tool MB991502 or MB991958 to the data link connector.
- (2) Turn the ignition switch to the "ON" position.
- (3) Read the DTC.
- (4) Turn the ignition switch to the "LOCK" (OFF) position.

#### **Q: Is DTC P0107 set?**

**YES** : Refer to, DTC P0107 – Barometric Pressure Circuit Low Input [P.13A-59](#).

**NO** : Go to Step 2.

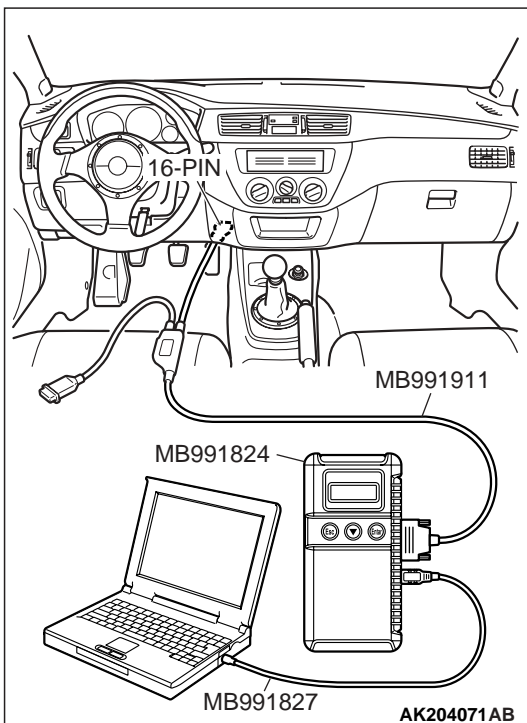
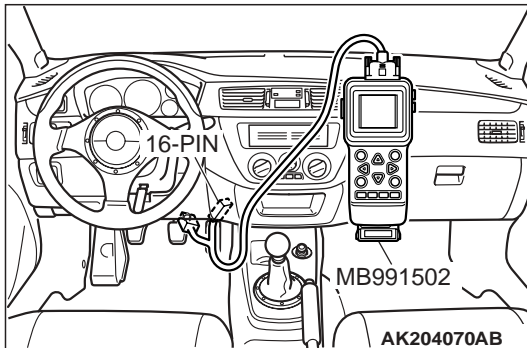

**STEP 2. Check connector B-105 at the barometric pressure sensor for damage.**

#### **Q: Is the connector in good condition?**

**YES** : Go to Step 3.

**NO** : Repair or replace it. Refer to GROUP 00E, Harness Connector Inspection [P.00E-2](#). Then go to Step 9.

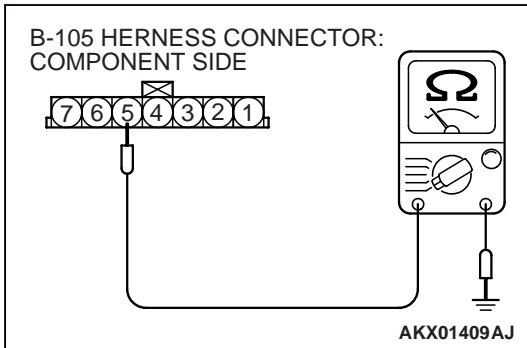
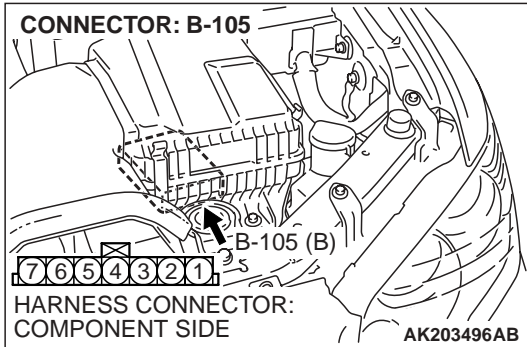

**STEP 3. Check for continuity at barometric pressure sensor harness side connector B-105.**

(1) Disconnect connector B-105 and measure at the harness side.

(2) Check for the continuity between terminal No. 5 and ground.

- Should be less than 2 ohms.

**Q: Does continuity exist?**

**YES :** Go to Step 6.

**NO :** Go to Step 4.

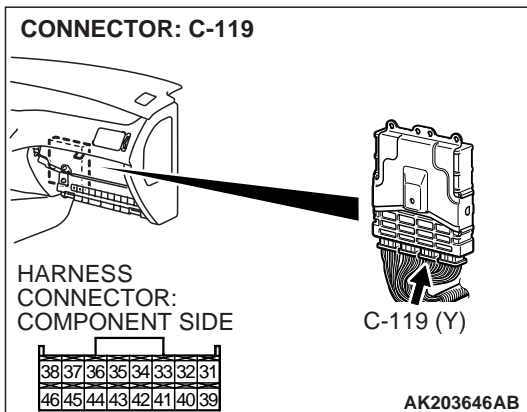

**STEP 4. Check harness connector C-119 at ECM for damage.**

**Q: Is the harness connector in good condition?**

**YES :** Go to Step 5.

**NO :** Repair or replace it. Refer to GROUP 00E, Harness Connector Inspection P.00E-2. Then go to Step 9.



**STEP 5. Check for open circuit and harness damage between barometric pressure sensor connector B-105 (terminal No. 5) and ECM connector C-119 (terminal No. 40).**

**Q: Is the harness wire in good condition?**

**YES :** Replace the ECM. Then go to Step 9.

**NO :** Repair it. Then go to Step 9.

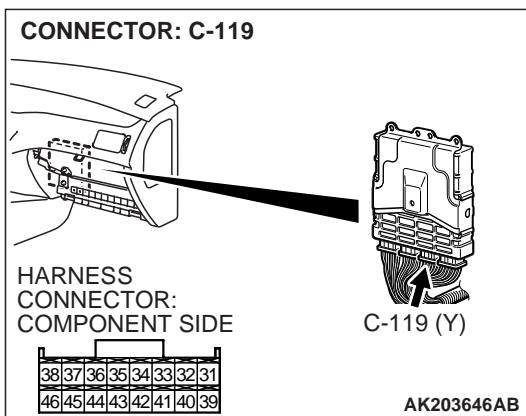
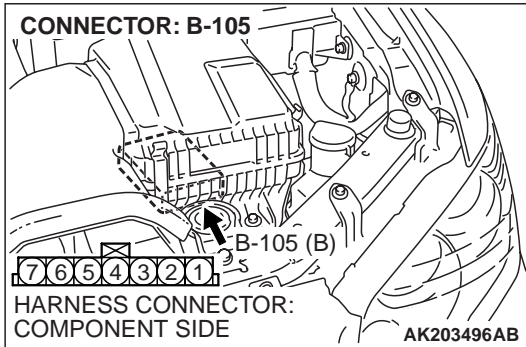

**STEP 6. Check harness connector C-115 at ECM for damage.**

**Q: Is the harness connector in good condition?**

**YES :** Go to Step 7.

**NO :** Repair or replace it. Refer to GROUP 00E, Harness Connector Inspection [P.00E-2](#). Then go to Step 9.

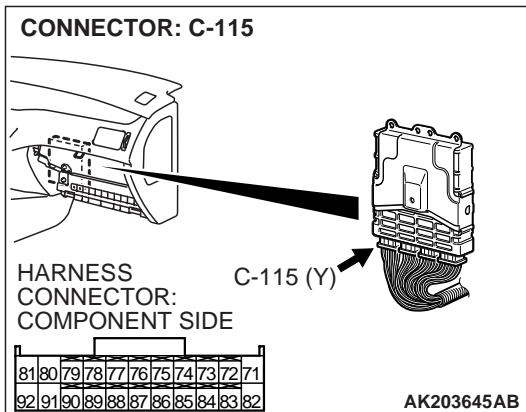

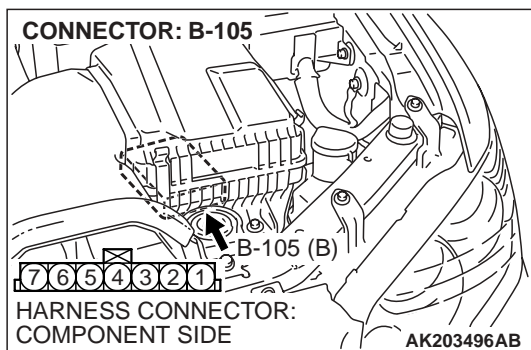
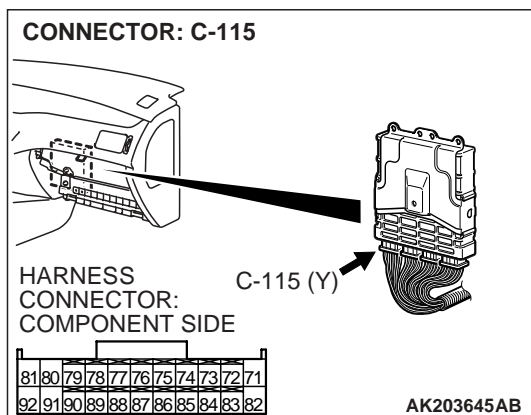
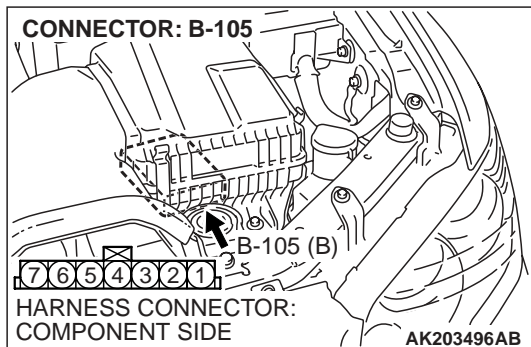

**STEP 7. Check for open circuit and harness damage between barometric pressure sensor connector B-105 and ECM connector C-115.**

**Q: Is the harness wire in good condition?**

**YES :** Go to Step 8.

**NO :** Repair it. Then go to Step 9.

**STEP 8. Replace the barometric pressure sensor.**

- (1) Replace the barometric pressure sensor.
- (2) Carry out a test drive with the drive cycle pattern. Refer to GROUP 13A, Diagnostic Function – OBD-II Drive Cycle – Procedure 6 – Other Monitor [P.13A-6](#).
- (3) Check the diagnostic trouble code (DTC).

**Q: Is DTC P0106 set?**

**YES :** Replace the ECM. Then go to Step 9.

**NO :** The procedure is complete.

**STEP 9. Perform the OBD-II drive cycle.**

- (1) Carry out a test drive with the drive cycle pattern. Refer to GROUP 13A, Diagnostic Function – OBD-II Drive Cycle – Procedure 6 – Other Monitor [P.13A-6](#).
- (2) Check the diagnostic trouble code (DTC).

**Q: Is DTC P0106 set?**

**YES :** Repeat the troubleshooting.

**NO :** The procedure is complete.

DTC P0107: BAROMETRIC PRESSURE CIRCUIT LOW INPUT

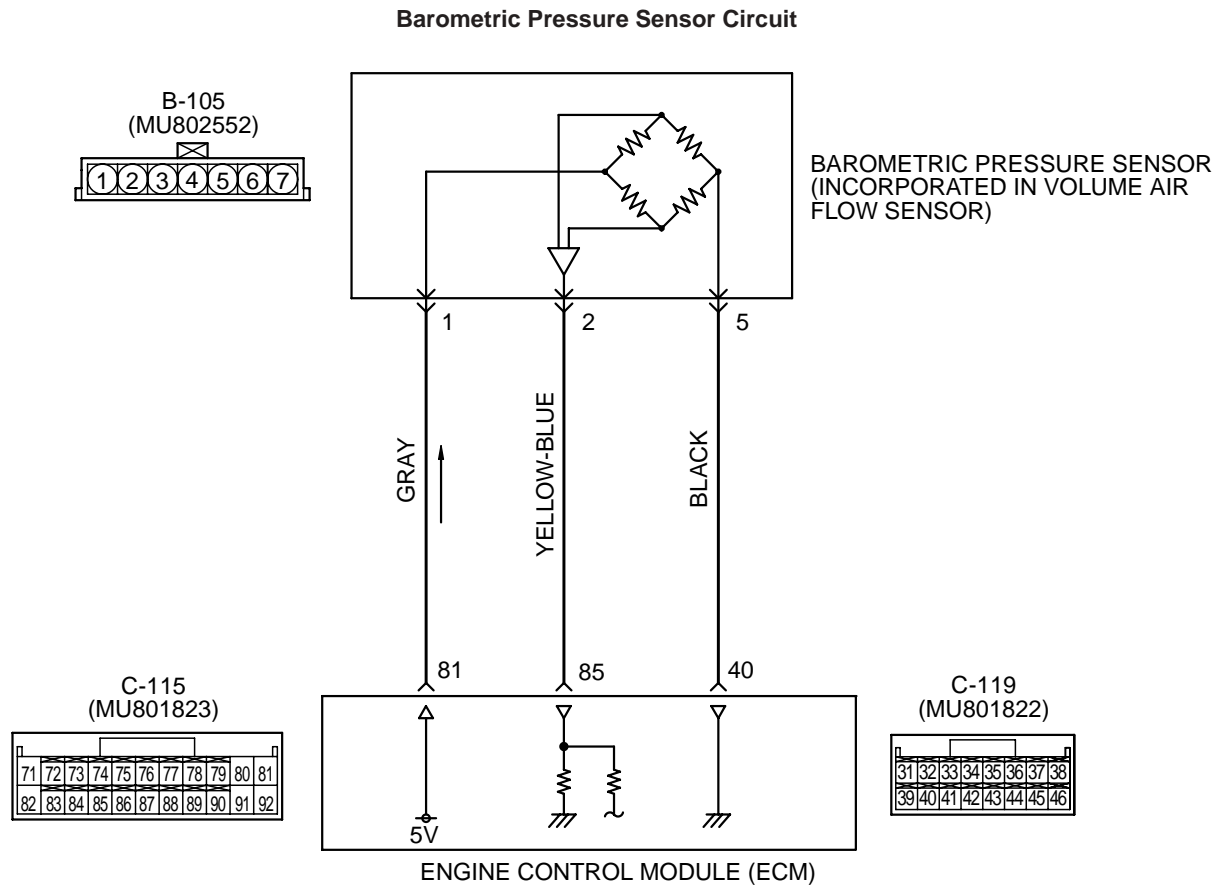

AK203497

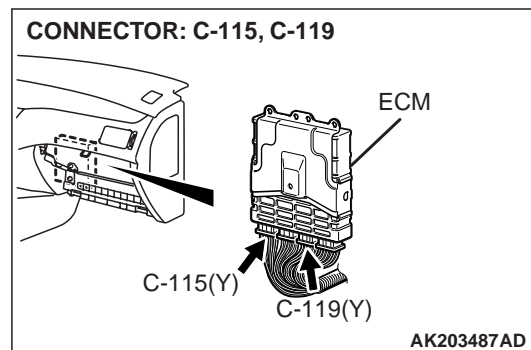
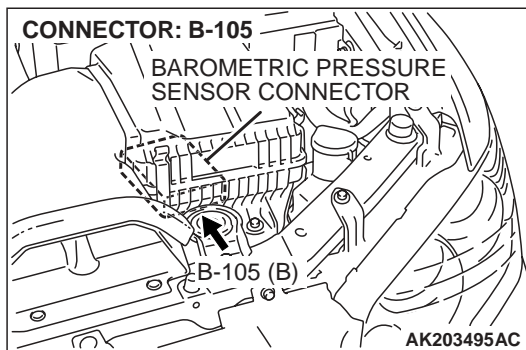

**CIRCUIT OPERATION**

- A 5-volt voltage is supplied to the barometric pressure sensor power terminal (terminal No. 1) from the ECM (terminal No. 81). The ground terminal (terminal No. 5) is grounded with ECM (terminal No. 40).
- A voltage that is proportional to the atmospheric pressure is sent to the ECM (terminal No. 85) from the barometric pressure sensor output terminal (terminal No. 2).

**TECHNICAL DESCRIPTION**

- The barometric pressure sensor outputs a voltage which corresponds to the barometric pressure.
- The ECM checks whether this voltage is within a specified range.

### DTC SET CONDITIONS

#### Check Conditions

- 2 seconds or more have passed since the starting sequence was completed.
- Battery positive voltage is higher than 8 volts.

#### Judgement Criteria

- Barometric pressure sensor output signal has continued to be approximately 49 kPa (7.2 psi) or lower (approximately 15,000 ft above sea level) for 10 seconds.

### TROUBLESHOOTING HINTS (The most likely causes for this code to be set are:)

- Barometric pressure sensor failed.
- Open or shorted barometric pressure sensor circuit, harness damage, or connector damage.
- ECM failed.

## DIAGNOSIS

### Required Special Tools:

- MB991502: Scan Tool (MUT-II)
- MB991958: Scan Tool (MUT-III Sub Assembly)
  - MB991824: V.C.I.
  - MB991827: USB Cable
  - MB991911: Main Harness B

**STEP 1. Using scan tool MB991502 or MB991958, check data list item 25: Barometric Pressure Sensor.**

### **⚠ CAUTION**

To prevent damage to scan tool MB991502 or MB991958, always turn the ignition switch to the "LOCK" (OFF) position before connecting or disconnecting scan tool MB991502 or MB991958.

- (1) Connect scan tool MB991502 or MB991958 to the data link connector.
- (2) Turn the ignition switch to the "ON" position.
- (3) Set scan tool MB991502 or MB991958 to the data reading mode for item 25, Barometric Pressure Sensor.
  - When altitude is 0 m (0 foot), 101 kPa (29.8 in.Hg).
  - When altitude is 600 m (1,969 feet), 95 kPa (28.1 in.Hg).
  - When altitude is 1,200 m (3,937 feet), 88 kPa (26.0 in.Hg).
  - When altitude is 1,800 m (5,906 feet), 81 kPa (23.9 in.Hg).
- (4) Turn the ignition switch to the "LOCK" (OFF) position.

### **Q: Is the sensor operating properly?**

**YES :** It can be assumed that this malfunction is intermittent. Refer to GROUP 00, How to Use Troubleshooting/ Inspection Service Points [P.00-6](#).

**NO :** Go to Step 2.

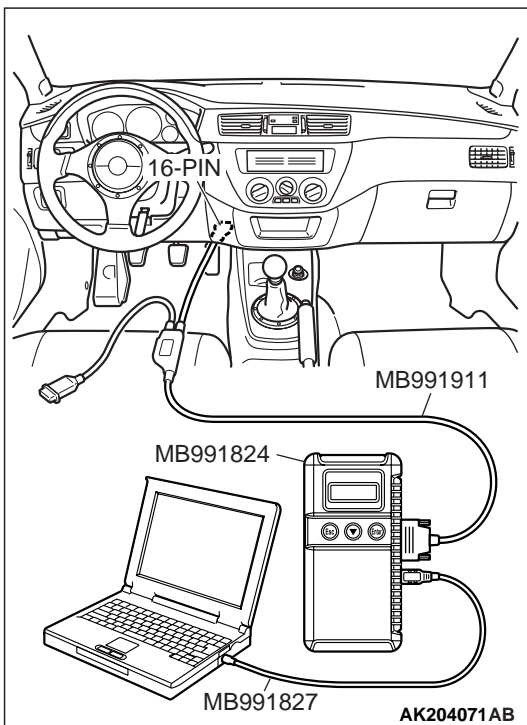
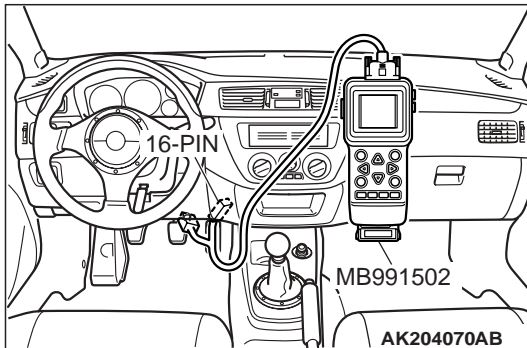

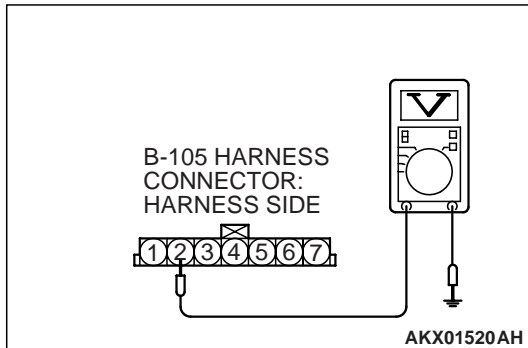
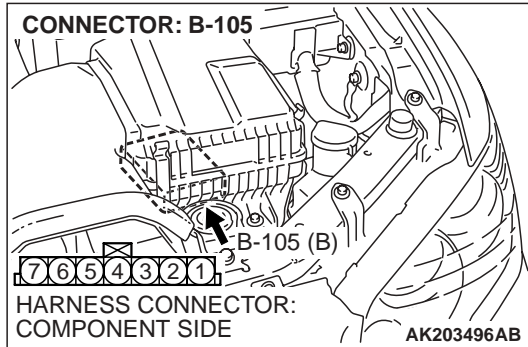

**STEP 2. Measure the sensor output voltage at barometric pressure sensor connector B-105 by backprobing.**

- (1) Do not disconnect connector B-105.
- (2) Turn the ignition switch to the "ON" position.

- (3) Measure the voltage between terminal No. 2 and ground by backprobing.

- When altitude is 0 m (0 foot), voltage should measure 3.7 and 4.3 volts.
- When altitude is 600 m (1,969 feet), voltage should measure 3.4 and 4.0 volts.
- When altitude is 1,200 m (3,937 feet), voltage should measure 3.2 and 3.8 volts.
- When altitude is 1,800 m (5,906 feet), voltage should measure 2.9 and 3.5 volts.

- (4) Turn the ignition switch to the "LOCK" (OFF) position.

**Q: Is the measured voltage within the specified range?**

**YES :** Go to Step 3.

**NO :** Go to Step 7.

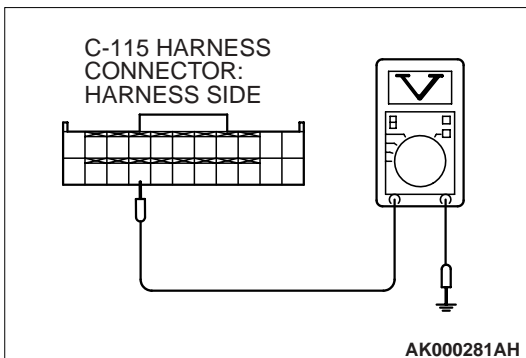
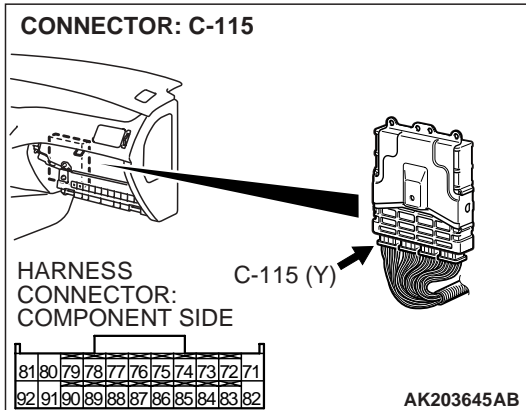

**STEP 3. Measure the sensor output voltage at ECM connector C-115 by backprobing.**

- (1) Do not disconnect connector C-115.
- (2) Turn the ignition switch to the "ON" position.

- (3) Measure the voltage between terminal No. 85 and ground by backprobing.

- When altitude is 0 m (0 foot), voltage should measure 3.7 and 4.3 volts.
- When altitude is 600 m (1,969 feet), voltage should measure 3.4 and 4.0 volts.
- When altitude is 1,200 m (3,937 feet), voltage should measure 3.2 and 3.8 volts.
- When altitude is 1,800 m (5,906 feet), voltage should measure 2.9 and 3.5 volts.

- (4) Turn the ignition switch to the "LOCK" (OFF) position.

**Q: Is the measured voltage within the specified range?**

**YES :** Go to Step 4.

**NO :** Go to Step 6.

**STEP 4.** Check harness connector B-105 at the barometric pressure sensor and harness connector C-115 at ECM for damage.

**Q:** Is the harness connector in good condition?

**YES :** Go to Step 5.

**NO :** Repair or replace it. Refer to GROUP 00E, Harness Connector Inspection [P.00E-2](#). Then go to Step 18.

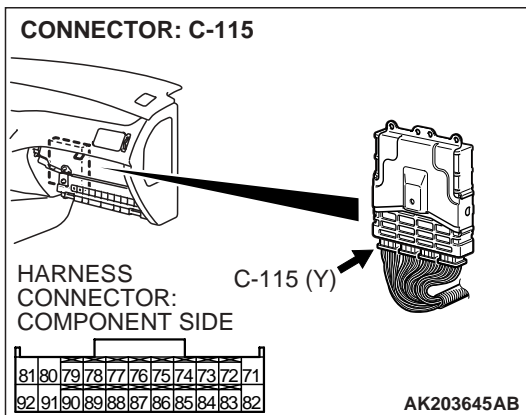
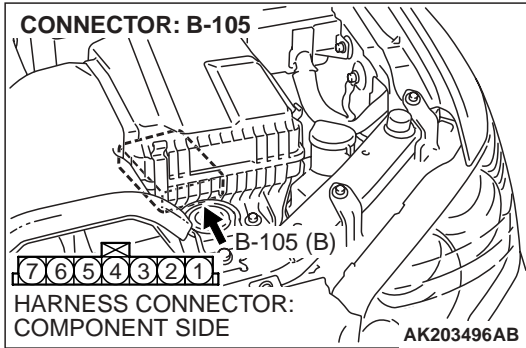



**STEP 5.** Using scan tool MB991502 or MB991958, check data list item 25: Barometric Pressure Sensor.

**⚠ CAUTION**

To prevent damage to scan tool MB991502 or MB991958, always turn the ignition switch to the "LOCK" (OFF) position before connecting or disconnecting scan tool MB991502 or MB991958.

- (1) Connect scan tool MB991502 or MB991958 to the data link connector.
- (2) Turn the ignition switch to the "ON" position.
- (3) Set scan tool MB991502 or MB991958 to the data reading mode for item 25, Barometric Pressure Sensor.
  - When altitude is 0 m (0 foot), 101 kPa (29.8 in.Hg).
  - When altitude is 600 m (1,969 feet), 95 kPa (28.1 in.Hg).
  - When altitude is 1,200 m (3,937 feet), 88 kPa (26.0 in.Hg).
  - When altitude is 1,800 m (5,906 feet), 81 kPa (23.9 in.Hg).
- (4) Turn the ignition switch to the "LOCK" (OFF) position.

**Q: Is the sensor operating properly?**

**YES :** It can be assumed that this malfunction is intermittent. Refer to GROUP 00, How to Use Troubleshooting/ Inspection Service Points [P.00-6](#).

**NO :** Replace the ECM. Then go to Step 18.

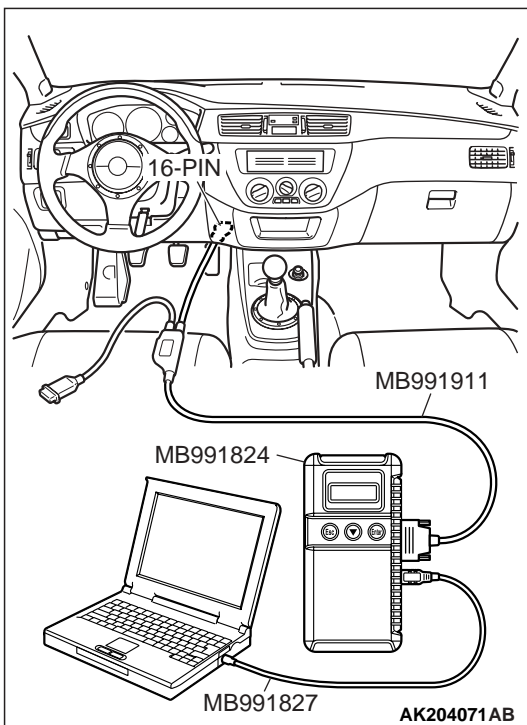
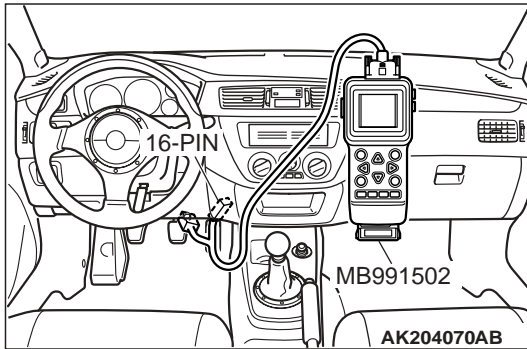

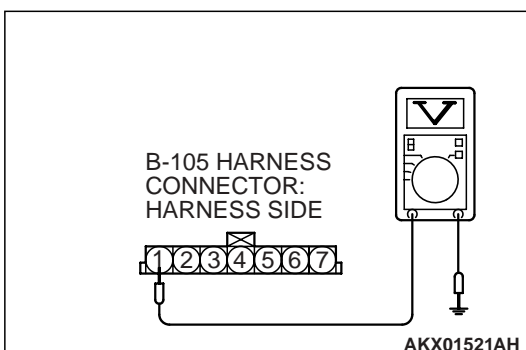
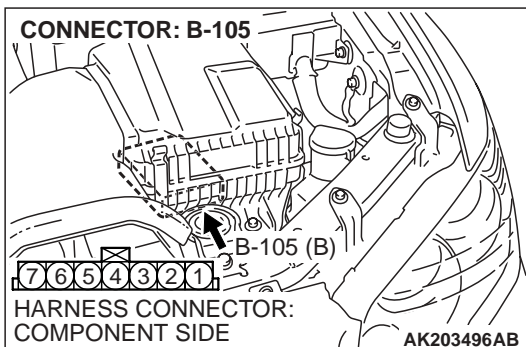
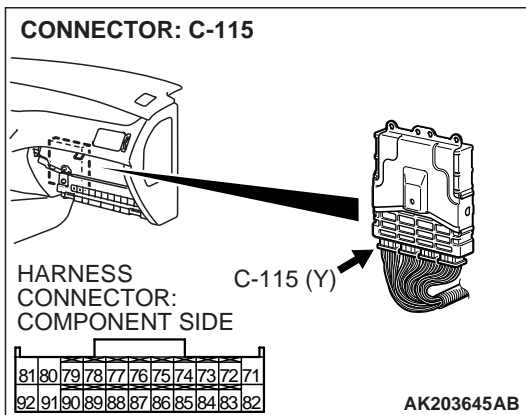
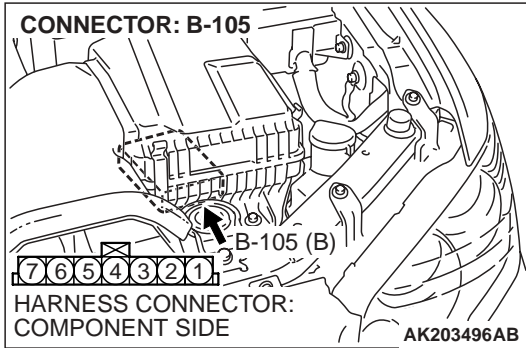

**STEP 6. Check harness connector B-105 at the barometric pressure sensor and harness connector C-115 at ECM for damage.**

**Q: Is the harness connector in good condition?**

- YES :** Repair harness wire between barometric pressure sensor connector B-105 (terminal No. 2) and ECM connector C-115 (terminal No. 85) because of open circuit or harness damage. Then go to Step 18.
- NO :** Repair or replace it. Refer to GROUP 00E, Harness Connector Inspection P.00E-2. Then go to Step 18.

**STEP 7. Measure the sensor supply voltage at barometric pressure sensor connector B-105 by backprobing.**

- (1) Do not disconnect connector B-105.
- (2) Turn the ignition switch to the "ON" position.
- (3) Measure the voltage between terminal No. 1 and ground by backprobing.
  - Voltage should measure between 4.8 and 5.2 volts.
- (4) Turn the ignition switch to the "LOCK" (OFF) position.

**Q: Is the measured voltage between 4.8 and 5.2 volts?**

- YES :** Go to Step 12.
- NO :** Go to Step 8.

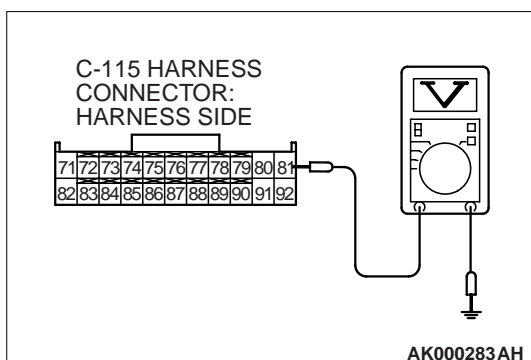
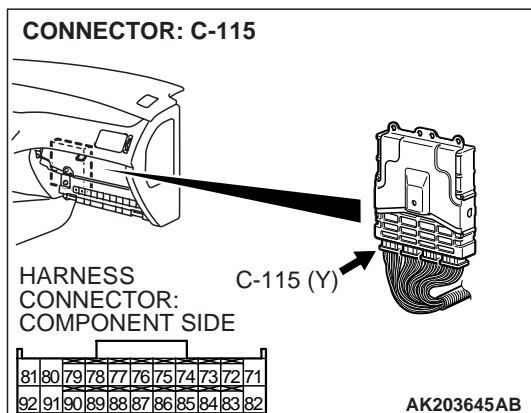

**STEP 8. Measure the sensor supply voltage at ECM connector C-115 by backprobing.**

- (1) Do not disconnect connector C-115.
- (2) Turn the ignition switch to the "ON" position.

- (3) Measure the voltage between terminal No. 81 and ground by backprobing.
  - Voltage should measure between 4.8 and 5.2 volts.

- (4) Turn the ignition switch to the "LOCK" (OFF) position.

**Q: Is the measured voltage between 4.8 and 5.2 volts?**

- YES :** Go to Step 9.  
**NO :** Go to Step 10.

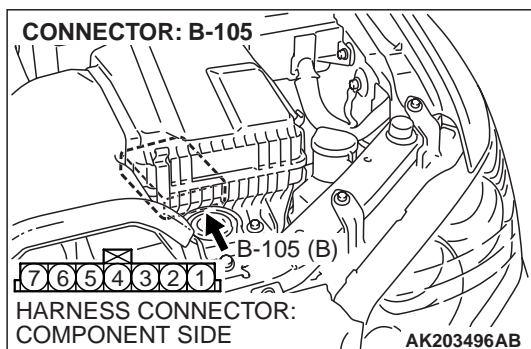

**STEP 9. Check harness connector B-105 at the barometric pressure sensor and harness connector C-115 at ECM for damage.**

**Q: Is the harness connector in good condition?**

- YES :** Repair harness wire between barometric pressure sensor connector B-105 (terminal No. 1) and ECM connector C-115 (terminal No. 81) because of open circuit or harness damage. Then go to Step 18.
- NO :** Repair or replace it. Refer to GROUP 00E, Harness Connector Inspection P.00E-2. Then go to Step 18.

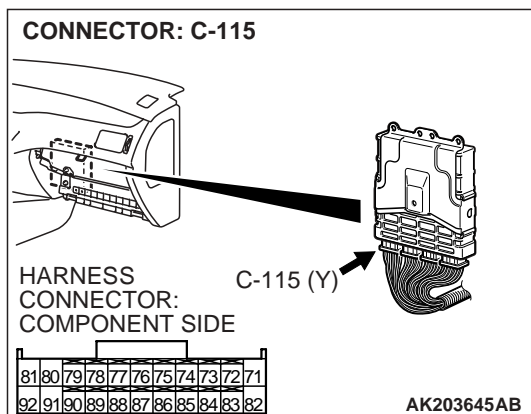

**STEP 10. Check harness connector B-105 at the barometric pressure sensor and harness connector C-115 at ECM for damage.**

**Q: Is the harness connector in good condition?**

**YES :** Go to Step 11.

**NO :** Repair or replace it. Refer to GROUP 00E, Harness Connector Inspection [P.00E-2](#). Then go to Step 18.

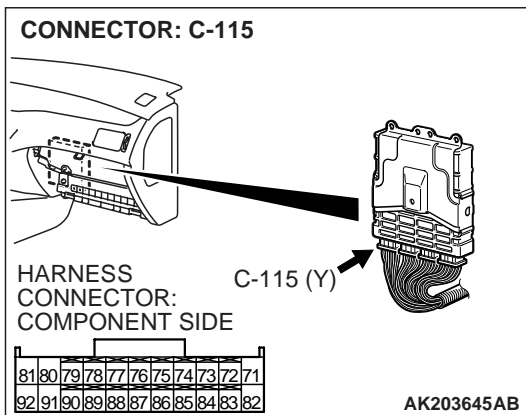
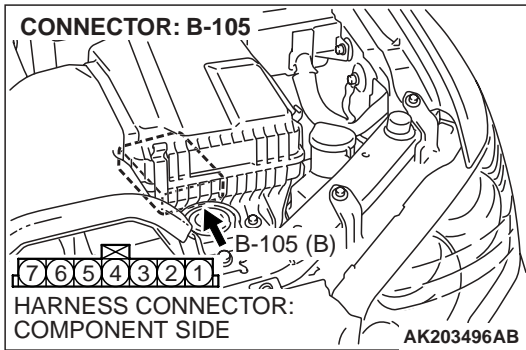

**STEP 11. Check for short circuit to ground between barometric pressure sensor connector B-105 (terminal No. 1) and ECM connector C-115 (terminal No. 81).**

**Q: Is the harness wire in good condition?**

- YES :** Replace the ECM. Then go to Step 18.
- NO :** Repair it. Then go to Step 18.

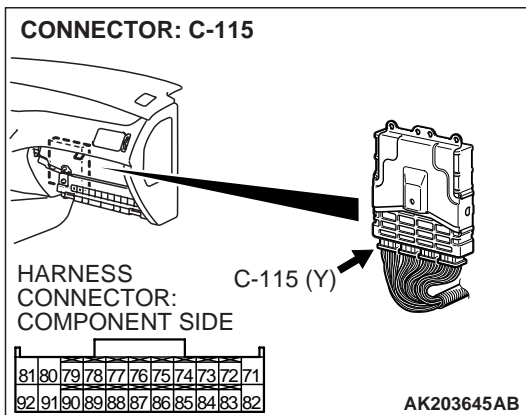
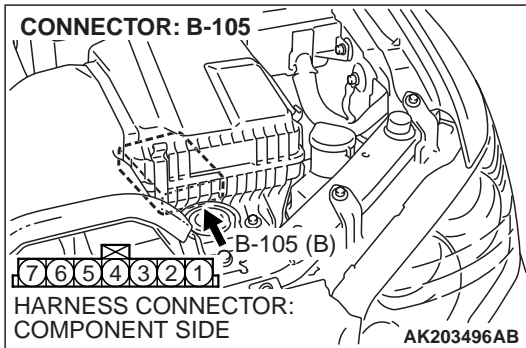

**STEP 12. Measure the ground voltage at barometric pressure sensor connector B-105 by backprobing.**

- (1) Do not disconnect connector B-105.
- (2) Turn the ignition switch to the "ON" position.

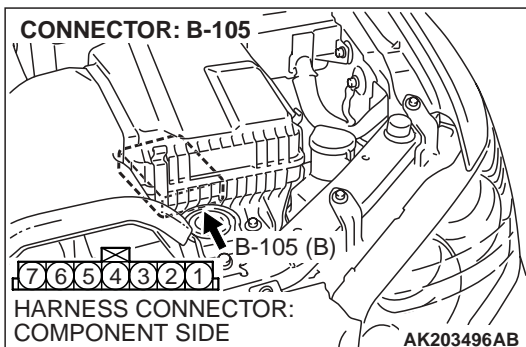

- (3) Measure the voltage between terminal No. 5 and ground by backprobing.
  - Voltage should measure 0.5 volt or less.
- (4) Turn the ignition switch to the "LOCK" (OFF) position.

**Q: Is the measured voltage 0.5 volt or less?**

- YES :** Go to Step 15.
- NO :** Go to Step 13.

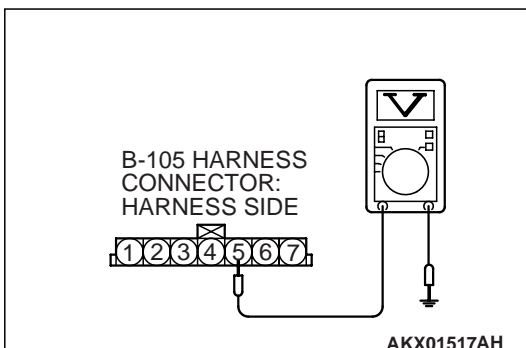

**STEP 13. Check harness connector B-105 at the barometric pressure sensor and harness connector C-119 at ECM for damage.**

**Q: Is the harness connector in good condition?**

**YES :** Go to Step 14.

**NO :** Repair or replace it. Refer to GROUP 00E, Harness Connector Inspection [P.00E-2](#). Then go to Step 18.

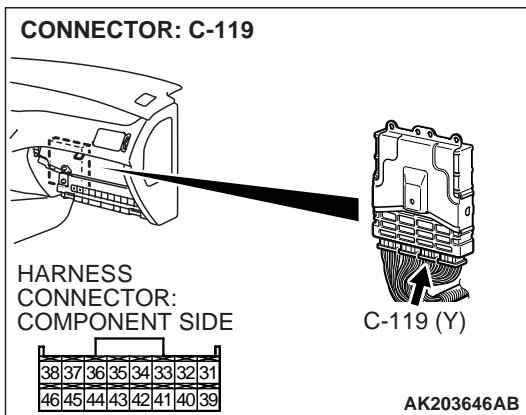
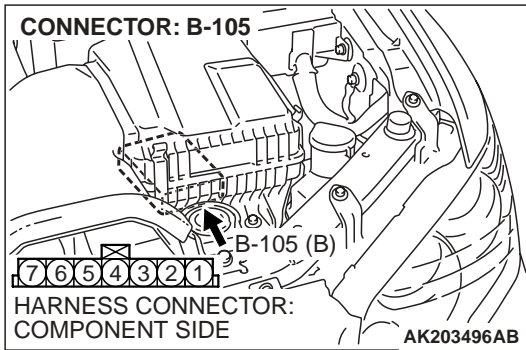

**STEP 14. Check for harness damage between barometric pressure sensor connector B-105 (terminal No. 5) and ECM connector C-119 (terminal No. 40).**

**Q: Is the harness wire in good condition?**

- YES :** Replace the ECM. Then go to Step 18.
- NO :** Repair it. Then go to Step 18.

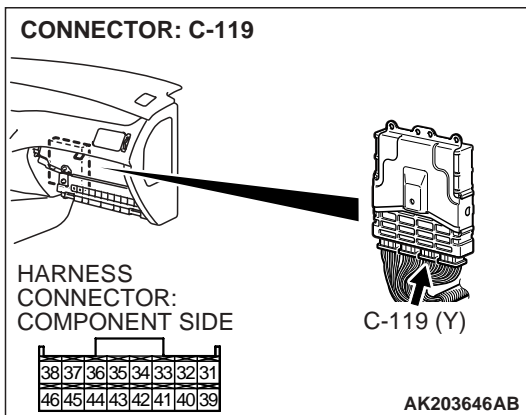
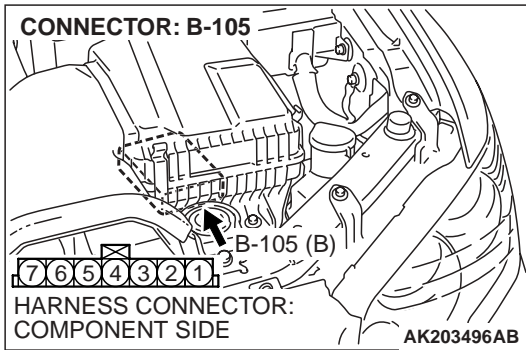

**STEP 15. Check harness connector B-105 at barometric pressure sensor for damage.**

**Q: Is the harness connector in good condition?**

- YES :** Go to Step 16.
- NO :** Repair or replace it. Refer to GROUP 00E, Harness Connector Inspection [P.00E-2](#). Then go to Step 18.

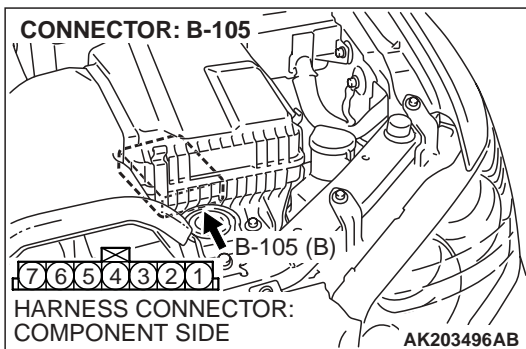

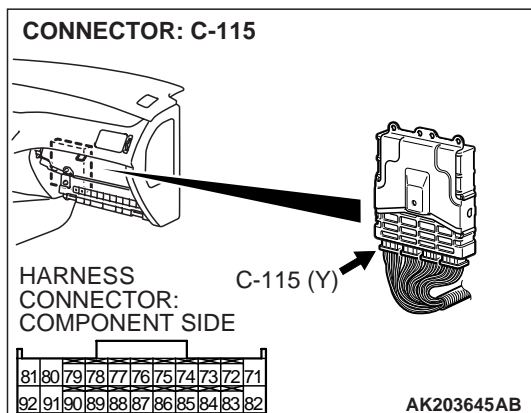

**STEP 16. Check harness connector C-115 at ECM for damage.**

**Q: Is the harness connector in good condition?**

**YES :** Go to Step 17.

**NO :** Repair or replace it. Refer to GROUP 00E, Harness Connector Inspection [P.00E-2](#). Then go to Step 18.

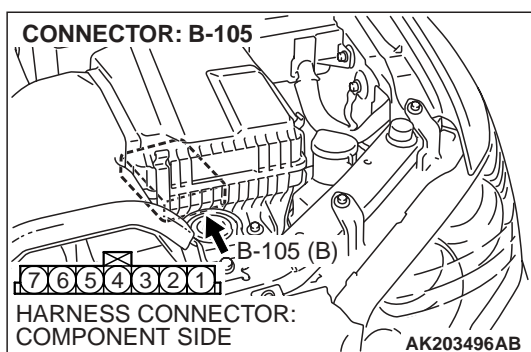

**STEP 17. Check for short circuit to ground and harness damage between barometric pressure sensor connector B-105 (terminal No. 2) and ECM connector C-115 (terminal No. 85).**

**Q: Is the harness wire in good condition?**

**YES :** Replace the volume airflow sensor. Then go to Step 18.

**NO :** Repair it. Then go to Step 18.

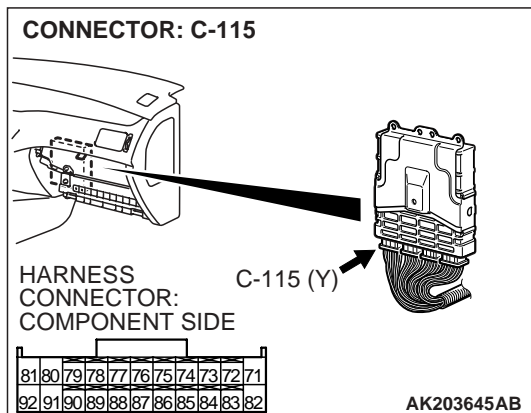

**STEP 18. Perform the OBD-II drive cycle.**

(1) Carry out a test drive with the drive cycle pattern. Refer to GROUP 13A, Diagnostic Function – OBD-II Drive Cycle – Procedure 6 – Other Monitor [P.13A-6](#).

(2) Check the diagnostic trouble code (DTC).

**Q: Is DTC P0107 set?**

**YES :** Repeat the troubleshooting.

**NO :** The procedure is complete.



DTC P0108: BAROMETRIC PRESSURE CIRCUIT HIGH INPUT

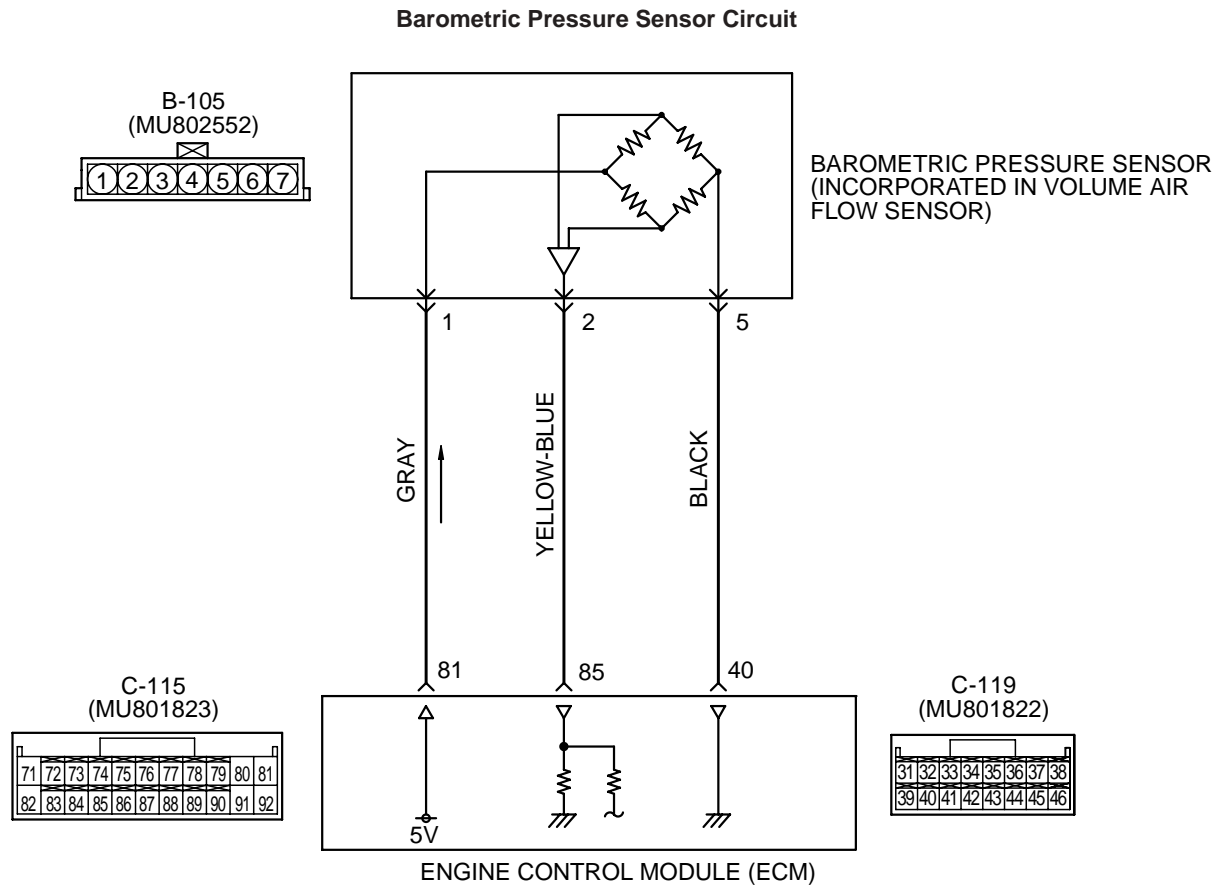

AK203497

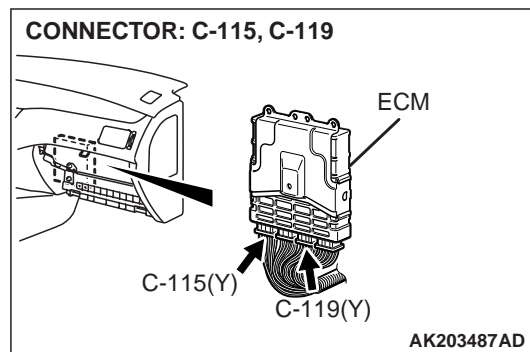
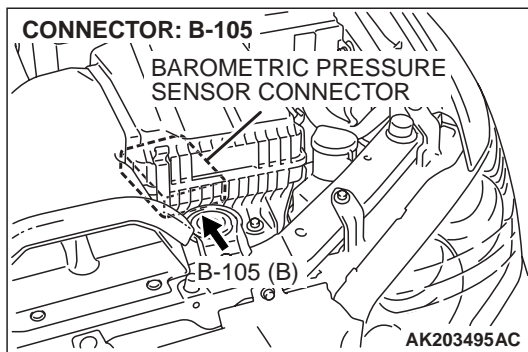

**CIRCUIT OPERATION**

- A 5-volt voltage is supplied to the barometric pressure sensor power terminal (terminal No. 1) from the ECM (terminal No. 81). The ground terminal (terminal No. 5) is grounded with ECM (terminal No. 40).
- A voltage that is proportional to the atmospheric pressure is sent to the ECM (terminal No. 85) from the barometric pressure sensor output terminal (terminal No. 2).

**TECHNICAL DESCRIPTION**

- The barometric pressure sensor outputs a voltage which corresponds to the barometric pressure.
- The ECM checks whether this voltage is within a specified range.

### DTC SET CONDITIONS

#### Check Conditions

- 2 seconds or more have passed since the starting sequence was completed.
- Battery positive voltage is higher than 8 volts.

#### Judgement Criteria

- Barometric pressure sensor output signal has continued to be approximately 113 kPa (16 psi) or higher (approximately 4,000 ft below sea level) for 10 seconds.

### TROUBLESHOOTING HINTS (The most likely causes for this code to be set are:)

- Barometric pressure sensor failed.
- Open barometric pressure sensor circuit, or connector damage.
- ECM failed.

## DIAGNOSIS

### Required Special Tools:

- MB991502: Scan Tool (MUT-II)
- MB991958: Scan Tool (MUT-III Sub Assembly)
  - MB991824: V.C.I.
  - MB991827: USB Cable
  - MB991911: Main Harness B

**STEP 1. Using scan tool MB991502 or MB991958, check data list item 25: Barometric Pressure Sensor.**

### **⚠ CAUTION**

To prevent damage to scan tool MB991502 or MB991958, always turn the ignition switch to the "LOCK" (OFF) position before connecting or disconnecting scan tool MB991502 or MB991958.

- (1) Connect scan tool MB991502 or MB991958 to the data link connector.
- (2) Turn the ignition switch to the "ON" position.
- (3) Set scan tool MB991502 or MB991958 to the data reading mode for item 25, Barometric Pressure Sensor.
  - When altitude is 0 m (0 foot), 101 kPa (29.8 in.Hg).
  - When altitude is 600 m (1,969 feet), 95 kPa (28.1 in.Hg).
  - When altitude is 1,200 m (3,937 feet), 88 kPa (26.0 in.Hg).
  - When altitude is 1,800 m (5,906 feet), 81 kPa (23.9 in.Hg).
- (4) Turn the ignition switch to the "LOCK" (OFF) position.

### **Q: Is the sensor operating properly?**

**YES :** It can be assumed that this malfunction is intermittent. Refer to GROUP 00, How to Use Troubleshooting/ Inspection Service Points [P.00-6](#).

**NO :** Go to Step 2.

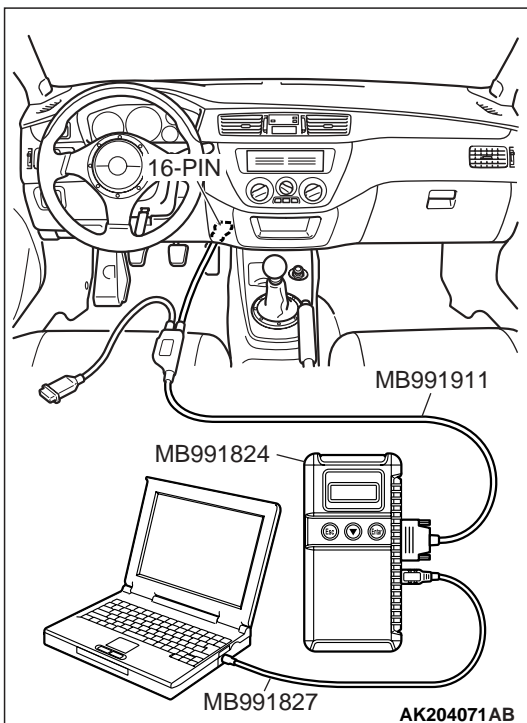
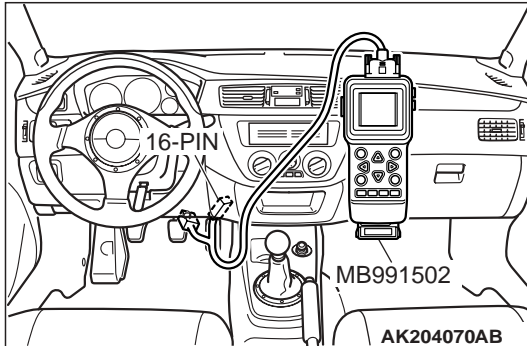

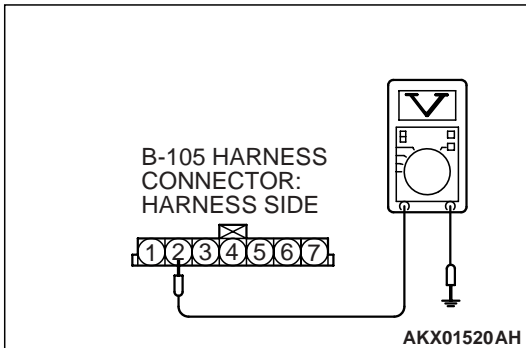
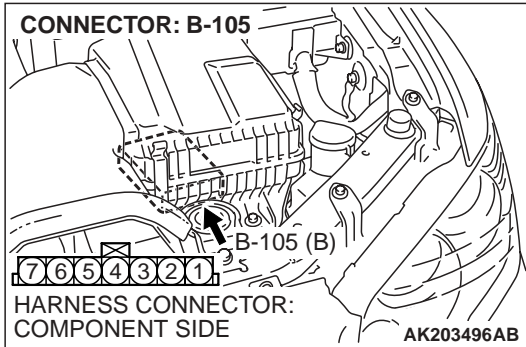

**STEP 2. Measure the sensor output voltage at barometric pressure sensor connector B-105 by backprobing.**

- (1) Do not disconnect connector B-105.
- (2) Turn the ignition switch to the "ON" position.

- (3) Measure the voltage between terminal No. 2 and ground by backprobing.

- When altitude is 0 m (0 foot), voltage should measure 3.7 and 4.3 volts.
- When altitude is 600 m (1,969 feet), voltage should measure 3.4 and 4.0 volts.
- When altitude is 1,200 m (3,937 feet), voltage should measure 3.2 and 3.8 volts.
- When altitude is 1,800 m (5,906 feet), voltage should measure 2.9 and 3.5 volts.

- (4) Turn the ignition switch to the "LOCK" (OFF) position.

**Q: Is the measured voltage within the specified range?**

**YES :** Go to Step 3.

**NO :** Go to Step 5.

**STEP 3.** Check harness connector B-105 at the barometric pressure sensor and harness connector C-115 at ECM for damage.

**Q:** Is the harness connector in good condition?

**YES :** Go to Step 4.

**NO :** Repair or replace it. Refer to GROUP 00E, Harness Connector Inspection [P.00E-2](#). Then go to Step 12.

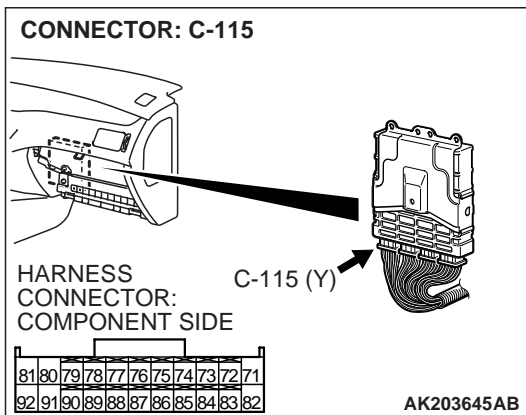
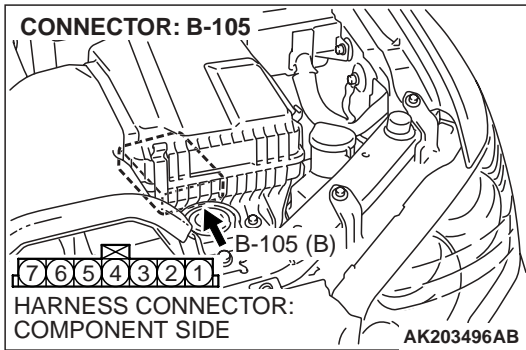

**STEP 4.** Using scan tool MB991502 or MB991958, check data list item 25: Barometric Pressure Sensor.

**⚠ CAUTION**

To prevent damage to scan tool MB991502 or MB991958, always turn the ignition switch to the "LOCK" (OFF) position before connecting or disconnecting scan tool MB991502 or MB991958.

- (1) Connect scan tool MB991502 or MB991958 to the data link connector.
- (2) Turn the ignition switch to the "ON" position.
- (3) Set scan tool MB991502 or MB991958 to the data reading mode for item 25, Barometric Pressure Sensor.
  - When altitude is 0 m (0 foot), 101 kPa (29.8 in.Hg).
  - When altitude is 600 m (1,969 feet), 95 kPa (28.1 in.Hg).
  - When altitude is 1,200 m (3,937 feet), 88 kPa (26.0 in.Hg).
  - When altitude is 1,800 m (5,906 feet), 81 kPa (23.9 in.Hg).
- (4) Turn the ignition switch to the "LOCK" (OFF) position.

**Q: Is the sensor operating properly?**

**YES :** It can be assumed that this malfunction is intermittent. Refer to GROUP 00, How to Use Troubleshooting/ Inspection Service Points [P.00-6](#).

**NO :** Replace the ECM. Then go to Step 12.

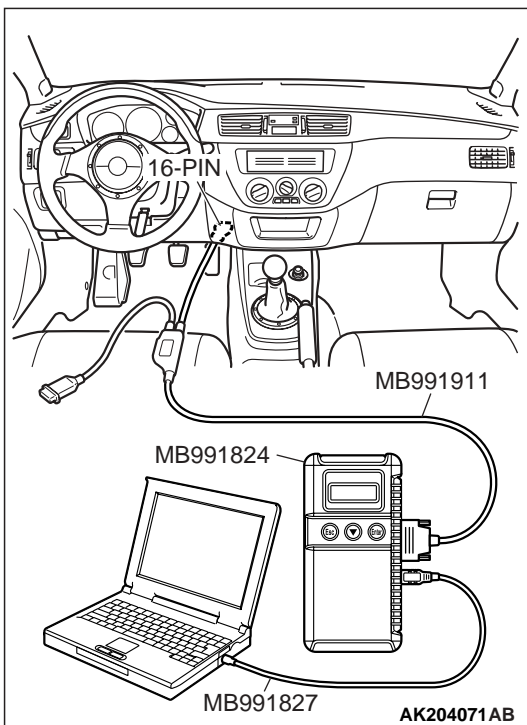
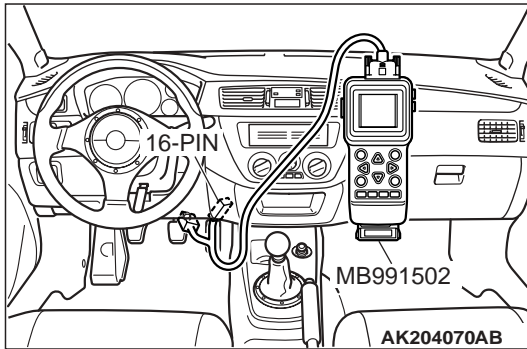

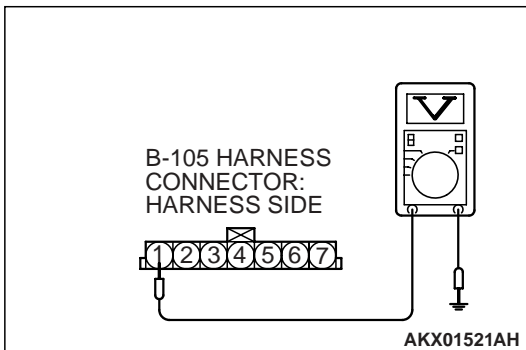
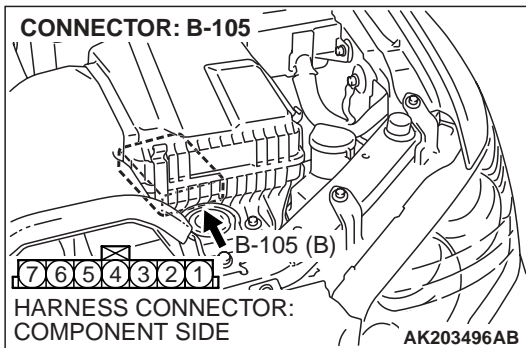

**STEP 5. Measure the sensor supply voltage at barometric pressure sensor connector B-105 by backprobing.**

- (1) Do not disconnect connector B-105.
- (2) Turn the ignition switch to the "ON" position.

- (3) Measure the voltage between terminal No. 1 and ground by backprobing.
  - Voltage should measure between 4.8 and 5.2 volts.

- (4) Turn the ignition switch to the "LOCK" (OFF) position.

**Q: Is the measured voltage between 4.8 and 5.2 volts?**

- YES :** Go to Step 7.  
**NO :** Go to Step 6.

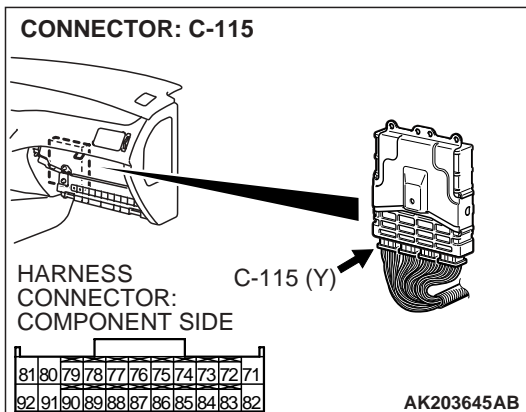

**STEP 6. Check harness connector C-115 at ECM for damage.**

**Q: Is the harness connector in good condition?**

- YES :** Replace the ECM. Then go to Step 12.  
**NO :** Repair or replace it. Refer to GROUP 00E, Harness Connector Inspection [P.00E-2](#). Then go to Step 12.

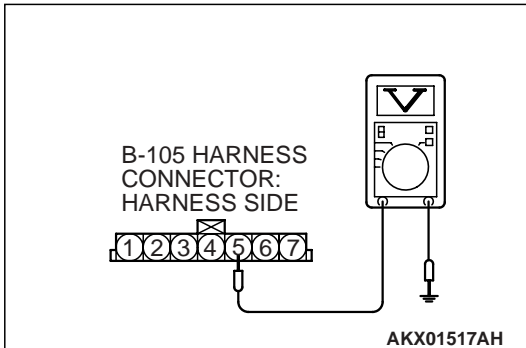
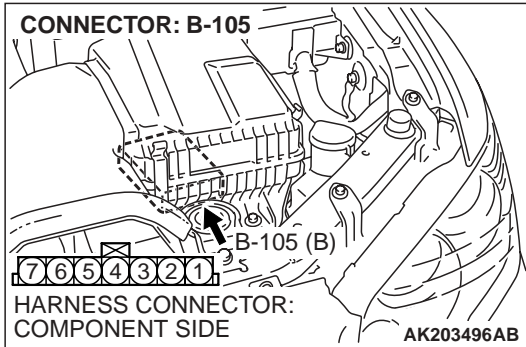

**STEP 7. Measure the ground voltage at barometric pressure sensor connector B-105 by backprobing.**

- (1) Do not disconnect connector B-105.
- (2) Turn the ignition switch to the "ON" position.

- (3) Measure the voltage between terminal No. 5 and ground by backprobing.
  - Voltage should measure 0.5 volt or less.

- (4) Turn the ignition switch to the "LOCK" (OFF) position.

**Q: Is the measured voltage 0.5 volt or less?**

- YES :** Go to Step 10.
- NO :** Go to Step 8.

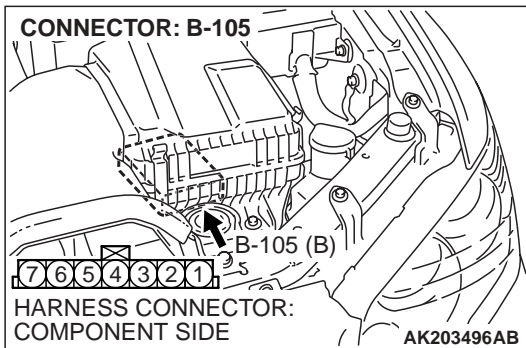

**STEP 8. Check harness connector B-105 at the barometric pressure sensor and harness connector C-119 at ECM for damage.**

**Q: Is the harness connector in good condition?**

- YES :** Go to Step 9.
- NO :** Repair or replace it. Refer to GROUP 00E, Harness Connector Inspection P.00E-2. Then go to Step 12.

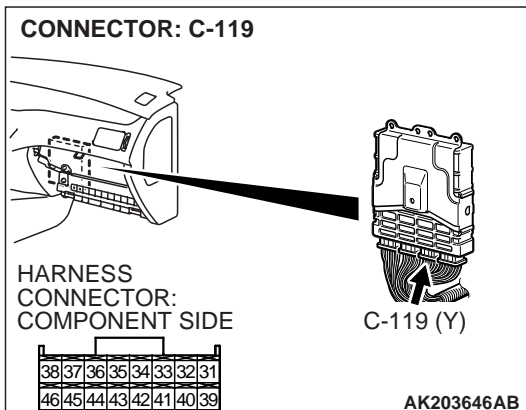



**STEP 9. Check for open circuit between barometric pressure sensor connector B-105 (terminal No. 5) and ECM connector C-119 (terminal No. 40).**

**Q: Is the harness wire in good condition?**

- YES :** Replace the ECM. Then go to Step 12.
- NO :** Repair it. Then go to Step 12.

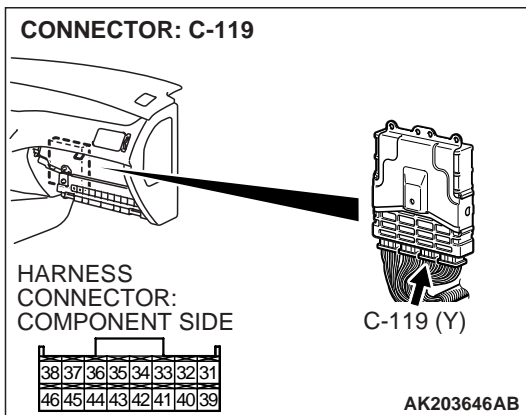
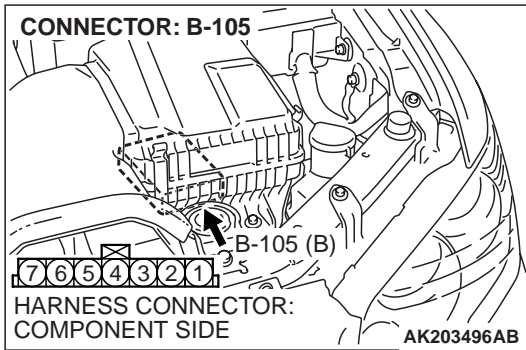

**STEP 10. Check harness connector B-105 at barometric pressure sensor for damage.**

**Q: Is the harness connector in good condition?**

- YES :** Go to Step 11.
- NO :** Repair or replace it. Refer to GROUP 00E, Harness Connector Inspection [P.00E-2](#). Then go to Step 12.

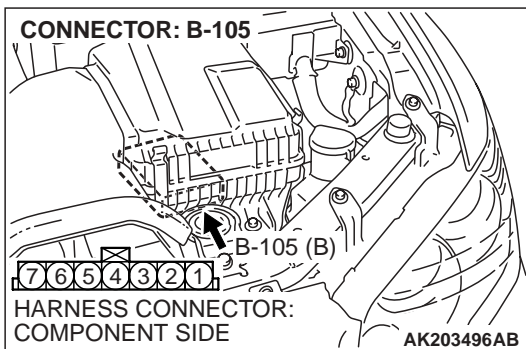

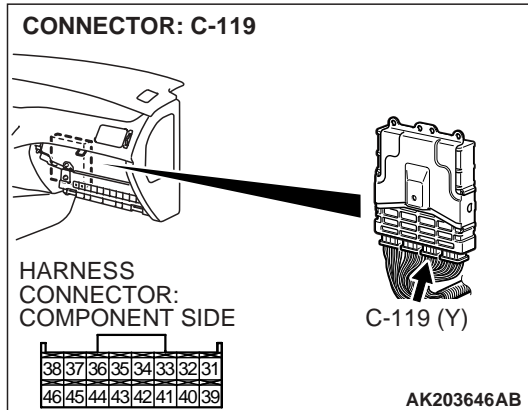

**STEP 11. Check harness connector C-119 at ECM for damage.**

**Q: Is the harness connector in good condition?**

**YES :** Replace the volume airflow sensor. Then go to Step 12.

**NO :** Repair or replace it. Refer to GROUP 00E, Harness Connector Inspection [P.00E-2](#). Then go to Step 12.

**STEP 12. Perform the OBD-II drive cycle.**

(1) Carry out a test drive with the drive cycle pattern. Refer to GROUP 13A, Diagnostic Function – OBD-II Drive Cycle – Procedure 6 – Other Monitor [P.13A-6](#).

(2) Check the diagnostic trouble code (DTC).

**Q: Is DTC P0108 set?**

**YES :** Repeat the troubleshooting.

**NO :** The procedure is complete.