

GROUP 35A

SERVICE BRAKES

CONTENTS

GENERAL DESCRIPTION	35A-2	BRAKE PEDAL	35A-22
BASIC BRAKE SYSTEM DIAGNOSIS	35A-3	REMOVAL AND INSTALLATION	35A-22
INTRODUCTION TO BASIC BRAKE SYSTEM DIAGNOSIS	35A-3	INSPECTION.....	35A-23
BASIC BRAKE SYSTEM DIAGNOSTIC TROUBLESHOOTING STRATEGY	35A-3	MASTER CYLINDER ASSEMBLY AND BRAKE BOOSTER	35A-24
SYMPTOM CHART.....	35A-3	REMOVAL AND INSTALLATION	35A-24
SYMPTOM PROCEDURES	35A-3	MASTER CYLINDER	35A-26
SPECIAL TOOLS	35A-12	INSPECTION.....	35A-27
ON-VEHICLE SERVICE	35A-12	FRONT DISC BRAKE ASSEMBLY ..	35A-27
BRAKE PEDAL CHECK AND ADJUSTMENT	35A-12	REMOVAL AND INSTALLATION	35A-27
BRAKE BOOSTER OPERATING TEST ...	35A-14	INSPECTION.....	35A-28
CHECK VALVE OPERATION CHECK....	35A-14	DISASSEMBLY AND ASSEMBLY	35A-29
BLEEDING	35A-15	INSPECTION.....	35A-30
BRAKE FLUID LEVEL SENSOR CHECK..	35A-16	REAR DISC BRAKE ASSEMBLY ...	35A-31
FRONT DISC BRAKE PAD CHECK AND REPLACEMENT.....	35A-16	REMOVAL AND INSTALLATION	35A-31
DISC BRAKE ROTOR CHECK.....	35A-18	INSPECTION.....	35A-32
BRAKE DISC THICKNESS CHECK.....	35A-19	DISASSEMBLY AND ASSEMBLY	35A-33
BRAKE DISC RUN-OUT CHECK AND CORRECTION	35A-20	INSPECTION.....	35A-34
MASTER CYLINDER FUNCTION CHECK.	35A-21	SPECIFICATIONS	35A-35
		FASTENER TIGHTENING SPECIFICATIONS.....	35A-35
		GENERAL SPECIFICATIONS	35A-36
		SERVICE SPECIFICATIONS	35A-36
		LUBRICANTS	35A-37
		SEALANT	35A-37

GENERAL DESCRIPTION

M1351000100365

Top components such as Brembo™ brakes, EBD and sports ABS improve braking power and braking stability.

CAUTION

Take care not to contact the parts or tools to the caliper because the paint of caliper will be scratched.

FEATURES

Improved braking performance

1. A 8+9-inch tandem vacuum booster is utilized to provide high braking force with a small pedal depression force.
2. Brembo™ 17-inch 4-pot front ventilated disc brakes and Brembo™ 16-inch 2-pot rear ventilated disc brakes are adopted to provide stable braking force and improved braking feel.

Improved stability

1. Sports ABS (4-wheel anti-lock braking system) is used to prevent slipping caused by the vehicle wheels locking up in order to maintain an appropriate braking distance, and also to maintain a stable vehicle posture and steering performance.
2. Adoption of an electronic brake-force distribution (EBD) makes it possible to maintain the maximum amount of braking force even when the vehicle's load is unevenly distributed.
3. Front- and rear-wheel X-type brake line layout is used.
4. Ventilated discs improve anti-fading performance.

Improved serviceability

1. A diagnosis function has been adopted for the ABS system in order to make inspection easier.
2. An outer disc method separated hub and rotor is featured to make removal and installation easier.
3. The master cylinder reservoir tank cap is colored white to make identification easier.
4. The ABS-ECU and hydraulic unit are integrated to make them more compact and light weight.

CONSTRUCTION DIAGRAM

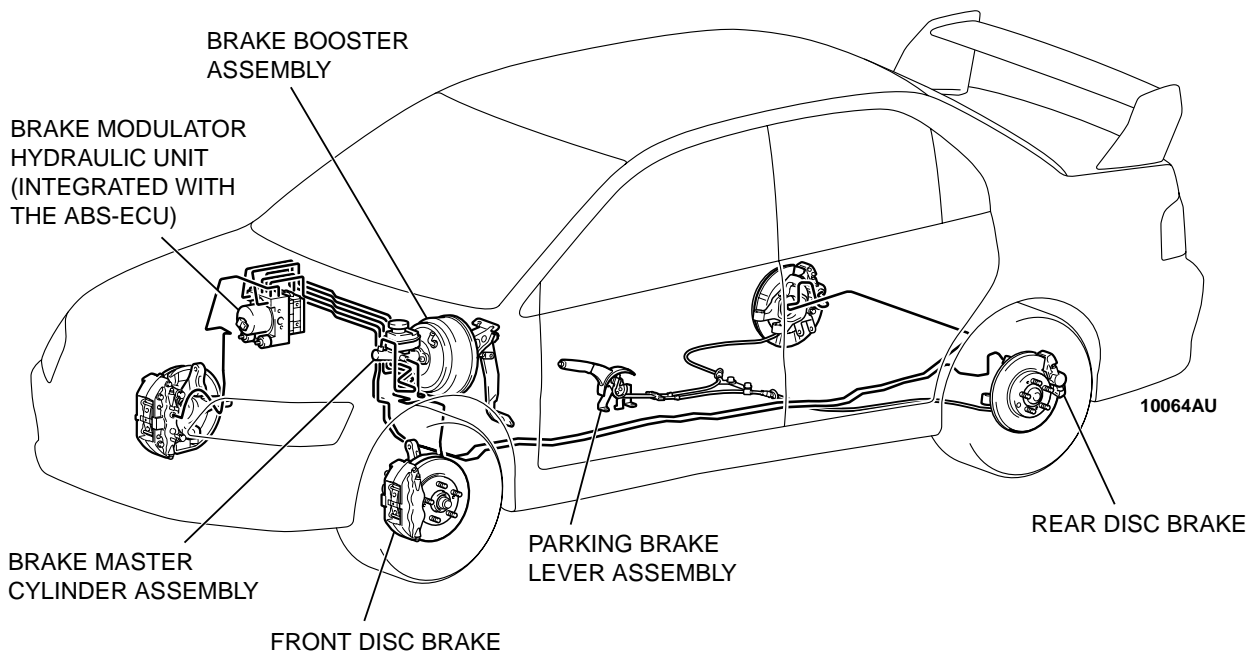

AC211387AB

BASIC BRAKE SYSTEM DIAGNOSIS

INTRODUCTION TO BASIC BRAKE SYSTEM DIAGNOSIS

M1351009700267

Hydraulic brakes are composed of the brake pedal, master cylinder, brake booster and disc brakes. Malfunctions such as insufficient braking power or the generation of noise may occur due to wear, damage or incorrect adjustment of these components.

BASIC BRAKE SYSTEM DIAGNOSTIC TROUBLESHOOTING STRATEGY

M1351009800264

Use these steps to plan your diagnostic strategy. If you follow them carefully, you will be sure that you have exhausted most of the possible ways to find a basic brake system fault.

1. Gather information from the customer.

2. Verify that the condition described by the customer exists.
3. Find the malfunction by following the symptom chart.
4. Verify malfunction is eliminated.

SYMPTOM CHART

M1351009900272

SYMPTOMS	INSPECTION PROCEDURE	REFERENCE PAGE
Vehicle pulls to one side when brakes are applied	1	P.35A-3
Insufficient braking power	2	P.35A-4
Increased pedal stroke (Reduced pedal-to-floor board clearance)	3	P.35A-5
Brake drag	4	P.35A-6
Scraping or grinding noise when brake are applied	5	P.35A-7
Squealing, groaning or chattering noise when brake are applied	6	P.35A-8
Squealing noise when brakes are not applied	7	P.35A-9
Groaning, clicking or rattling noise when brakes are not applied	8	P.35A-11

SYMPTOM PROCEDURES

INSPECTION PROCEDURE 1: Vehicle Pulls to One Side when Brakes are Applied

DIAGNOSIS

STEP 1. Check for oil, water, etc., on the pad contact surface of all brakes.

Q: Is oil, water, etc., on the pad contact surface?

YES : Replace the part and determine the source/ cause of foreign material. Then go to Step 5.

NO : Go to Step 2.

STEP 2. Check disc brake pistons for smooth operation.

- (1) With engine not running, depress the brake pedal rapidly several times to deplete booster vacuum reserves.
- (2) Test each disc brake assembly one at a time.
 - a. Remove the lower caliper bolt, then remove caliper from mount.
 - b. Have an assistant slowly depress the brake pedal. Confirm piston(s) extend slowly and smoothly with no jumpiness. Repeat for each disc brake assembly.

Q: Do (does) the piston(s) move correctly?**YES** : Go to Step 3.**NO** : Disassemble and inspect the brake assembly (Front: refer to [P.35A-29](#), Rear: refer to [P.35A-33](#)). Then go to Step 5.**STEP 3. Check brake disc(s) for run out.**Refer to [P.35A-20](#).**Q: Is runout outside of specifications?****YES** : Repair or replace the brake disc(s) as necessary. Then go to Step 5.**NO** : Go to Step 4.**STEP 4. Check brake discs for correct thickness.**Refer to [P.35A-19](#).**Q: Is the thickness outside of specifications?****YES** : Repair or replace the brake disc(s) as necessary. Then go to Step 5.**NO** : Carry out the brake line bleeding. Then go to Step 5.**STEP 5. Retest the system.****Q: Is the symptom eliminated?****YES** : The procedure is complete.**NO** : Start over at Step 1. If a new symptom appears, refer to the appropriate symptom chart.**INSPECTION PROCEDURE 2: Insufficient Braking Power****DIAGNOSIS****STEP 1. Check that the specified brake fluid is used, its level is correct, and no contamination is found.****Q: Is there fault?****YES** : Refill or replace with the specified brake fluid DOT 3 or DOT 4. Bleed the brakes if necessary (Refer to [P.35A-15](#)). Then go to Step 6.**NO** : Go to Step 2.**STEP 2. Check for spongy (not firm brakes).**

- (1) With engine not running, depress the brake pedal rapidly several times to deplete booster vacuum reserve.
- (2) With the brake pedal fully released, depress the brake pedal slowly until it stops.
- (3) With a measuring stick (ruler, etc.) next to the brake pedal, depress the pedal firmly and measure the distance the pedal traveled.

Q: Is the distance greater than 20 mm (0.8 inch)?**YES** : Bleed the brakes to remove air in the fluid (Refer to [P.35A-15](#)). Then go to Step 6.**NO** : Go to Step 3.**STEP 3. Check the brake booster function.**Refer to [P.35A-14](#).**Q: Is there fault?****YES** : Replace the brake booster. Then go to Step 6.**NO** : Go to Step 4.**STEP 4. Check for pinched or restricted brake tube or hose.****Q: Is there a pinched or restricted brake tube or hose?****YES** : Replace that complete section of brake tube or brake hose. Then go to Step 6.**NO** : Go to Step 5.**STEP 5. Check for oil, water, etc., on the pad contact surfaces of all brakes.****Q: Is oil, water, etc., on the pad contact surface?****YES** : Replace the part and determine the source/cause of foreign material. Recheck symptom. Then go to Step 6.**NO** : The procedure is complete.

STEP 6. Recheck symptom.

Q: Is the symptom eliminated?

YES : The procedure is complete.

NO : Start over at step 1. If a new symptom surfaces, refer to the appropriate symptom chart.

INSPECTION PROCEDURE 3: Increased Pedal Stroke (Reduced Pedal-to-Floor Board Clearance)

DIAGNOSIS

STEP 1. Check for spongy (not firm brakes).

- (1) With engine not running, depress the brake pedal rapidly several times to deplete booster vacuum reserve.
- (2) With the brake pedal fully released, depress the brake pedal slowly until it stops.
- (3) With a measuring stick (ruler, etc.) next to the brake pedal, depress the pedal firmly and measure the distance the pedal traveled.

Q: Is the distance greater than 20 mm (0.8 inch)?

YES : Bleed the brakes to remove air in the fluid (Refer to [P.35A-15](#)). Then go to Step 7.

NO : Go to Step 2.

STEP 2. Check the pad for wear.

Refer to [P.35A-16](#).

Q: Is the pad thickness outside of specifications?

YES : Replace the part. Then go to Step 7.

NO : Go to Step 3.

STEP 3. Check the vacuum hose and check valve for damage.

Refer to [P.35A-14](#).

Q: Is there damage?

YES : Replace the part. Then go to Step 7.

NO : Go to Step 4.

STEP 4. Check the master cylinder function.

Refer to [P.35A-21](#).

Q: Is there fault?

YES : Repair it. Then go to Step 7.

NO : Go to Step 5.

STEP 5. Check for brake fluid leaks.

Q: Is there leaks?

YES : Check the connection for looseness, corrosion, etc. Clean and repair as necessary. If leaking in any tube or hose section, replace the complete tube or hose. Then go to Step 7 .

NO : Go to Step 6.

STEP 6. Check the clearance (too much) between the push rod and primary piston.

Refer to [P.35A-24](#).

Q: Is the clearance outside of specifications?

YES : Adjust the clearance. Then go to Step 7.

NO : Go to Step 7.

STEP 7. Recheck symptom.

Q: Is the symptom eliminated?

YES : The procedure is complete.

NO : Start over at step 1. If a new symptom surfaces, refer to the symptom chart.

INSPECTION PROCEDURE 4: Brake Drag

DIAGNOSIS

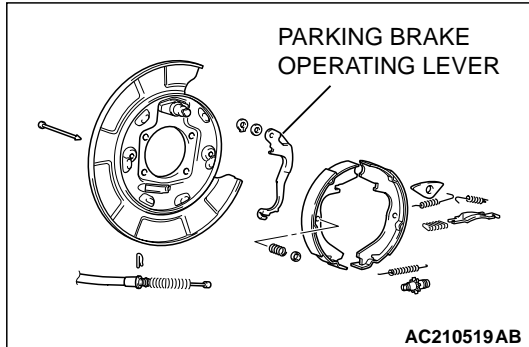

STEP 1. Check the parking brake operating lever return.

Q: Is there fault?

YES : Repair it. Then go to Step 9.

NO : Go to Step 2.

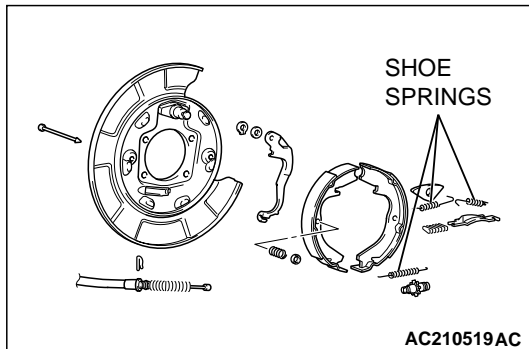

STEP 2. Check the brake shoe springs for breakage.

Q: Are the brake shoe springs broken?

YES : Replace the spring. Then go to Step 9.

NO : Go to Step 3.

STEP 3. Check the amount of grease at each sliding section.

Refer to GROUP 36, Parking Brake Lining and Drum [P.36-8](#).

Q: Is the grease amount low?

YES : Apply grease. Then go to Step 9.

NO : Go to Step 4.

STEP 4. Check the parking brake pull amount.

Refer to GROUP 36, On-vehicle Service – Parking Brake Lever Stroke Check and Adjustment [P.36-4](#).

Q: Is there fault?

YES : Adjust it. Then go to Step 9.

NO : Go to Step 5.

STEP 5. Check the clearance (too low) between the push rod and primary piston.

Refer to [P.35A-24](#).

Q: Is there fault?

YES : Adjust the clearance. Then go to Step 9.

NO : Go to Step 6.

STEP 6. Check the master cylinder piston return spring for damage and return port for clogging.

Refer to [P.35A-26](#).

Q: Is there damage?

YES : Replace the part. Then go to Step 9.

NO : Go to Step 7.

STEP 7. Check port for clogging.

Q: Is the port clogged?

YES : Repair it. Then go to Step 9.

NO : Go to Step 8.

STEP 8. Check disc brake pistons for sticking.

Depress the brake pedal, then release. Confirm each wheel spins freely.

Q: Are all wheels stuck?

YES : Inspect that brake assembly. Then go to Step 9.

NO : Go to Step 9.

STEP 9. Recheck symptom.

Q: Is the symptom eliminated?

YES : The procedure is complete.

NO : Start over at step 1. If a new symptom surfaces, refer to the symptom chart.

INSPECTION PROCEDURE 5: Scraping or Grinding Noise when Brakes are Applied

DIAGNOSIS

STEP 1. Check the front brakes, then rear brakes, for metal-to-metal condition.

Q: Is the metal-to-metal contact evident?

YES : Repair or replace the components. Then go to Step 6.

NO : Go to Step 2.

STEP 2. Check for interference between the caliper and wheel.

Q: Is there interference?

YES : Repair or replace the part. Then go to Step 6.

NO : Go to Step 3.

STEP 3. Check for interference between the dust cover and brake disc.

Q: Is there interference?

YES : Repair or replace the part. Then go to Step 6.

NO : Go to Step 4.

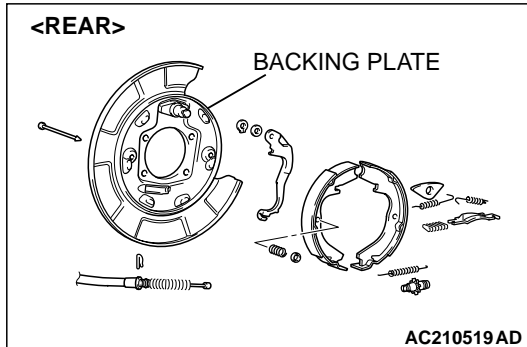
STEP 4. Check the brake discs for cracks.**Q: Are there cracks?****YES :** Repair or replace the part. Then go to Step 6.**NO :** Go to Step 5.**STEP 5. Check for bent backing plate(s).****Q: Is (Are) the backing plate(s) bent?****YES :** Repair or replace the part. Then go to Step 6.**NO :** Go to Step 6.**STEP 6. Recheck symptom.****Q: Is the symptom eliminated?****YES :** The procedure is complete.**NO :** Start over at step 1. If a new symptom surfaces, refer to the symptom chart.**INSPECTION PROCEDURE6: Squealing, Groaning or Chattering Noise when Brakes are Applied****DIAGNOSIS****STEP 1. Check the brake disc and pads for wear or cutting.****Q: Is there wear or cutting?****YES :** Repair or replace the part. Then go to Step 4.**4.****NO :** Go to Step 2.**STEP 2. Check the calipers for rust.****Q: Is there rust?****YES :** Remove the rust. Then go to Step 4.**NO :** Go to Step 3.**STEP 3. Adjust the brake pedal or brake booster pushrod.**Refer to [P.35A-12](#) or [P.35A-24](#).**Q: Are the brake pedal and the brake booster pushrod adjusted correctly?****YES :** Go to Step 4.**NO :** Adjust the brake pedal or the brake booster pushrod. Then go to Step 4.**STEP 4. Recheck symptom.****Q: Is the symptom eliminated?****YES :** The procedure is complete.**NO :** Start over at step 1. If a new symptom surfaces, refer to the symptom chart.

INSPECTION PROCEDURE 7: Squealing Noise when Brakes are not Applied

DIAGNOSIS

STEP 1. Check whether the backing plate is bent or loose and interfering with the drum.

Q: Is there fault?

YES : Replace the part. Then go to Step 10.

NO : Go to Step 2.

STEP 2. Check whether the drum is damaged due to interference with the backing plate or shoe.

Q: Is there damage?

YES : Replace the part. Then go to Step 10.

NO : Go to Step 3.

STEP 3. Check the brake drum for wear and the shoe spring for damage.

Q: Is there wear or damage?

YES : Replace the part. Then go to Step 10.

NO : Go to Step 4.

STEP 4. Check the brake discs for rust.

Q: Are the brake discs rusted?

YES : Remove the rust by using sand paper. If still rusted, turn the rotors with an on-the-car brake lathe. Then go to Step 10.

NO : Go to Step 5.

STEP 5. Check the brake pads for correct installation.

Q: Are the pads installed incorrectly?

YES : Repair the pads. Then go to Step 10.

NO : Go to Step 6.

STEP 6. Check the calipers for correct installation.

Q: Are the calipers installed incorrectly?

YES : Repair the calipers. Then go to Step 10.

NO : Go to Step 7.

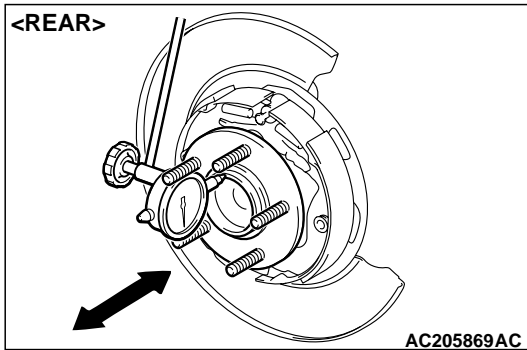
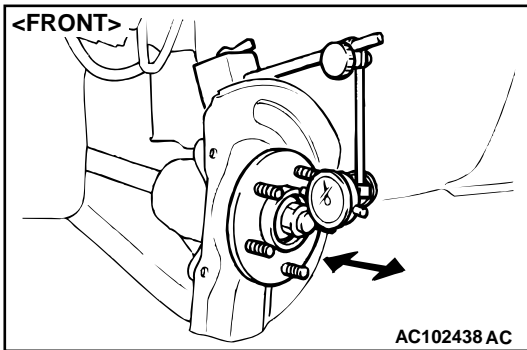
**STEP 7. Check the wheel bearings for end play.**

- (1) Remove the brake discs.
- (2) Place a dial gauge as shown, and measure the end play while moving the hub in the axial direction.

Limit: 0.05 mm (0.002 inch)

Q: Does the measured end play exceed the limit?

YES : Replace the faulty hub assembly. Then go to Step 10.

NO : Go to Step 8.

STEP 8. Check whether the brake booster or master cylinder return is insufficient.**Q: Is the brake booster or master cylinder return insufficient?**

YES : Replace the part. Then go to Step 10.

NO : Go to Step 9.

STEP 9. Adjust the brake pedal or brake booster pushrod.

Refer to [P.35A-12](#) or [P.35A-24](#).

Q: Are the brake pedal and the brake booster pushrod adjusted correctly?

YES : Go to Step 10.

NO : Adjust the brake pedal or the brake booster pushrod. Then go to Step 10.

STEP 10. Recheck symptom.**Q: Is the symptom eliminated?**

YES : The procedure is complete.

NO : Start over at step 1. If a new symptom surfaces, refer to the symptom chart.

INSPECTION PROCEDURE 8: Groaning, Clicking or Rattling Noise when Brakes are not Applied.

DIAGNOSIS

STEP 1. Check whether foreign material has entered the wheel covers.

Q: Is there foreign material?

YES : Remove it. Then go to Step 5.

NO : Go to Step 2.

STEP 2. Check for looseness of the wheel nuts.

Q: Are the wheel nuts loose?

YES : Tighten to 98 ± 10 N·m (73 ± 7 ft-lb). Then go to Step 5.

NO : Go to Step 3.

STEP 3. Check for looseness of the caliper installation bolt.

Q: Is the caliper installation bolt loose?

YES : Tighten to 108 ± 10 N·m (80 ± 7 ft-lb) for the front caliper. Tighten to 54 ± 5 N·m (40 ± 4 ft-lb) for the rear caliper. Then go to Step 5.

NO : Go to Step 4.

STEP 4. Check the wheel bearings for end play.

(1) Remove the brake discs.

(2) Place a dial gauge as shown, and measure the end play while moving the hub in the axial direction.

Limit: 0.05 mm (0.002 inch)

Q: Does the measured end play exceed the limit?

YES : Replace the faulty hub assembly. Then go to Step 5.

NO : Go to Step 5.

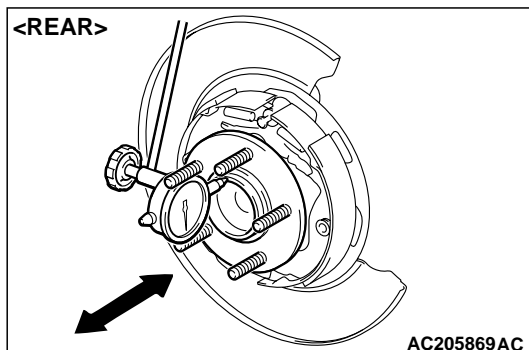
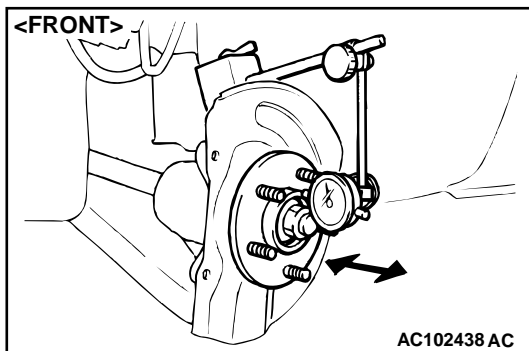

STEP 5. Recheck symptom.**Q: Is the symptom eliminated?****YES :** The procedure is complete.**NO :** Start over at step 1. If a new symptom surfaces, refer to the symptom chart.**SPECIAL TOOLS**

M1351000600285

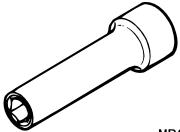
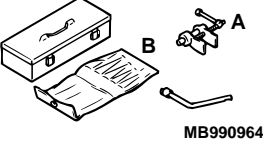
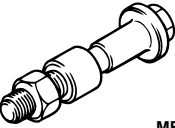
TOOL	TOOL NUMBER AND NAME	SUPERSESSION	APPLICATION
 MB991568	MB991568 Push rod adjusting socket	General service tool	Adjustment of the brake booster push rod protrusion amount
 MB990964	MB990964 Brake tool set A: MB990520 Disc brake piston expander B: MB990619 Installer	MB990619-01 or general service tool	<ul style="list-style-type: none"> Pushing-in of the disc brake piston Installation of the drum brake wheel cylinder piston cup
 MB990998	MB990998 Front hub remover and installer	MB990998-01	Provisional holding of the wheel bearing

ON-VEHICLE SERVICE**BRAKE PEDAL CHECK AND ADJUSTMENT**

M1351000900350

BRAKE PEDAL HEIGHT

- Turn up the carpet, etc. under the brake pedal.
- Measure the brake pedal height as illustrated.

Standard value (A): 169.1 – 172.1 mm (6.7 – 6.8 inches)
[From the surface of melting sheet (floorboard) to the face of pedal pad]

- If the brake pedal height is not within the standard value, follow the procedure below.
 - Disconnect the stoplight switch connector.
 - Loosen the stoplight switch by turning it approximately 1/4 turns anticlockwise.
 - Remove the brake booster. (Refer to [P.35A-24.](#))

NOTE: With the master cylinder and brake pipe connected, remove the brake booster only.

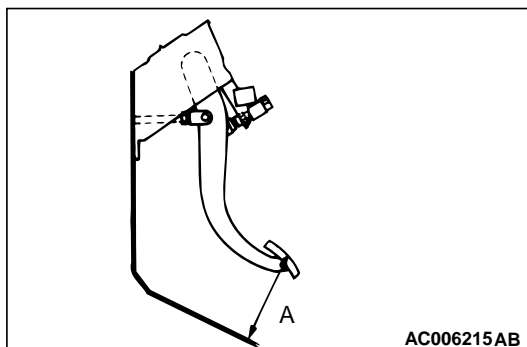

AC006215AB

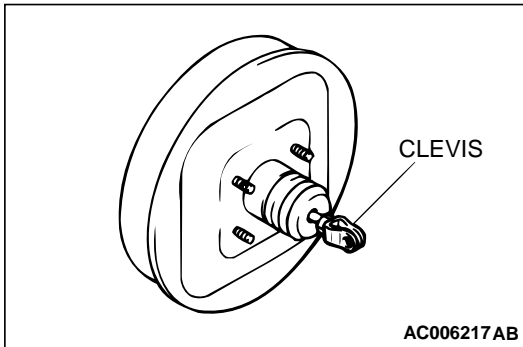

- (4) Adjust the brake pedal height by turning the clevis.
NOTE: When the clevis is turned 180 degrees, the pedal height is changed approximately 2.4 mm (0.09 in).
- (5) Install the brake booster. (Refer to [P.35A-24.](#))
- (6) Measure the brake pedal height, and ensure that the measured value is within the specified value. When it is out of the specified value, repeat Step (3) - (6).

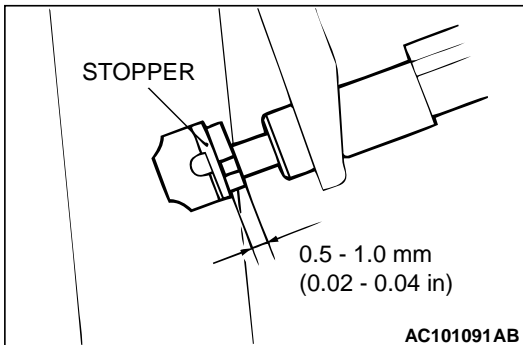

- (7) Insert the stoplight switch until its thread part touches the stopper. Then lock the stoplight switch by turning it approximately 1/4 turns clockwise, and confirm that the clearance between the switch plunger and the stopper is as shown.

⚠ CAUTION

Check that the stoplight does not illuminate when the brake pedal is not depressed.

- (8) Connect the connector at the stoplight switch.
4. Return the carpet, etc.

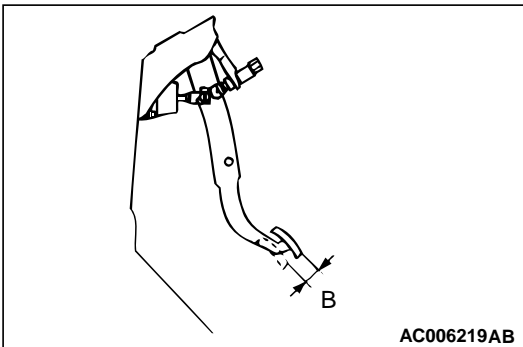

BRAKE PEDAL FREE PLAY

1. With the engine stopped, depress the brake pedal two or three times. After eliminating the vacuum in the power brake booster, press the pedal down by hand, and confirm that the amount of movement before resistance is met (the free play) is within the standard value.

Standard value (B): 3 – 8 mm (0.12 – 0.31 inch)

2. If the brake pedal play is not within the standard value, check the following, and adjust or replace if necessary:
 - Excessive play between the brake pedal and the clevis pin, or between the clevis pin and the brake booster operating rod
 - Brake pedal height
 - Installation position of the stoplight switch, etc.

CLEARANCE BETWEEN BRAKE PEDAL AND FLOORBOARD

1. Turn up the carpet, etc. under the brake pedal.
2. Start the engine, depress the brake pedal with approximately 500 N (112 pounds) of force, and measure the clearance between the brake pedal and the floorboard.

Standard value (C): 90 mm (3.5 inches) or more [From the surface of melting sheet (floorboard) to the face of pedal pad]

3. If the clearance is outside the standard value, check for air trapped in the brake line and thickness of the disc brake pad. And then bleed the air and replace the disc brake pad as required.
4. Return the carpet etc. to its original position.

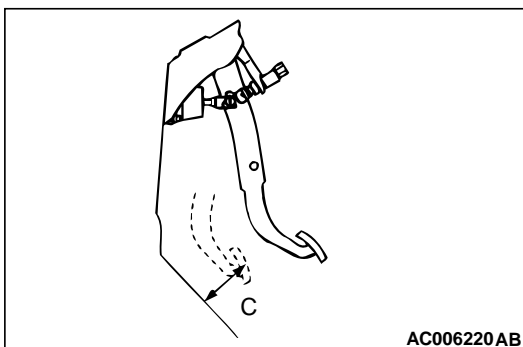

BRAKE BOOSTER OPERATING TEST

M1351001000286

1. For simple checking of the brake booster operation, carry out the following tests:

(1) Run the engine for one or two minutes, and then stop it. If the pedal depresses fully the first time but gradually becomes higher when depressed succeeding times, the booster is operating properly. If the pedal height remains unchanged, the booster is defective. Go to step 2.

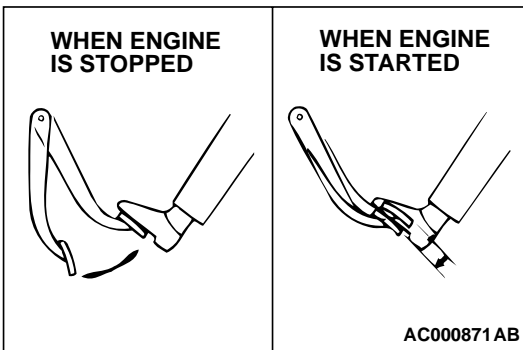
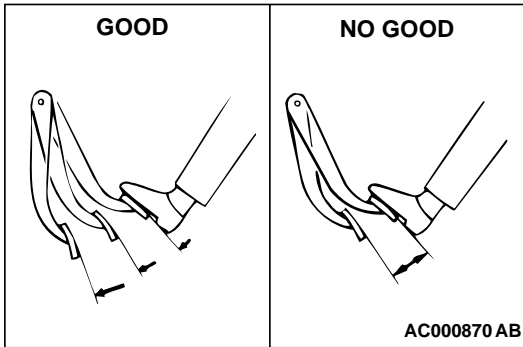

(2) With the engine stopped, step on the brake pedal several times. Then step on the brake pedal and start the engine. If the pedal moves downward slightly, the booster is in good condition. If there is no change, the booster is defective. Go to step 3.

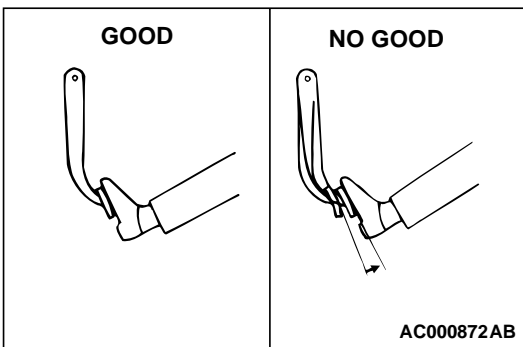

(3) With the engine running, step on the brake pedal and then stop the engine. Hold the pedal depressed for 30 seconds. If the pedal height does not change, the booster is in good condition, if the pedal rises, the booster is defective.

2. If the above three tests are okay, the booster is OK. If one of the above three tests is not okay, the check valve, vacuum hose, or booster is defective. Check the check valve (Refer to [P.35A-14.](#)), vacuum hose for leaks, high volume engine vacuum applied to booster. Repair or replace as necessary. If these are OK, replace booster and repeat this test starting at Step 1.

CHECK VALVE OPERATION CHECK

M1351009000280

⚠ CAUTION

The check valve should not be removed from the vacuum hose.

1. Remove the vacuum hose. (Refer to [P.35A-24.](#))

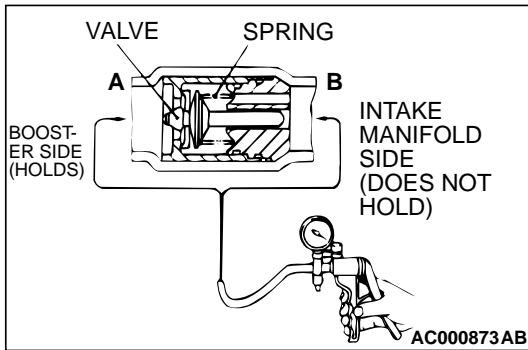

CAUTION

If the check valve is defective, replace it as an assembly unit together with the vacuum hose.

2. Check the operation of the check valve by using a vacuum pump.

VACUUM PUMP CONNECTION	CRITERIA
Connection at the brake booster side (A)	A negative pressure (vacuum) is created and held.
Connection at the intake manifold side (B)	A negative pressure (vacuum) is not created.

BLEEDING

M1351001400369

CAUTION

Use only brake fluid DOT 3 or DOT 4. Never mix the specified brake fluid with other fluid as it will influence the braking performance significantly.

MASTER CYLINDER BLEEDING

The master cylinder used has no check valve, so if bleeding is carried out by the following procedure, bleeding of air from the brake pipeline will become easier. (When brake fluid is not contained in the master cylinder.)

1. Fill the reserve tank with brake fluid.
2. Keep the brake pedal depressed.
3. Have another person cover the master cylinder outlet with a finger.
4. With the outlet still closed, release the brake pedal.
5. Repeat steps 2 – 4 three or four times to fill the inside of the master cylinder with brake fluid.

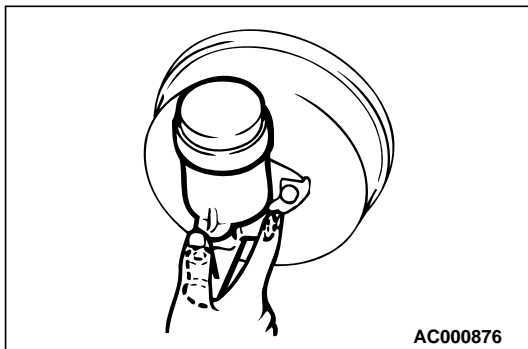

DISC BRAKE BLEEDING

CAUTION

Take care not to contact the parts or tools to the caliper because the paint of caliper will be scratched. And if there is brake fluid on the caliper, wipe out quickly.

Connect a vinyl tube to the outer end of the air bleeder screw to bleed the circuit of air. Then, connect the vinyl tube to the inner end and bleed the circuit of air. Except for these, the conventional procedures shall be followed. After the circuit has been bled of air, tighten both air bleeder screws securely.

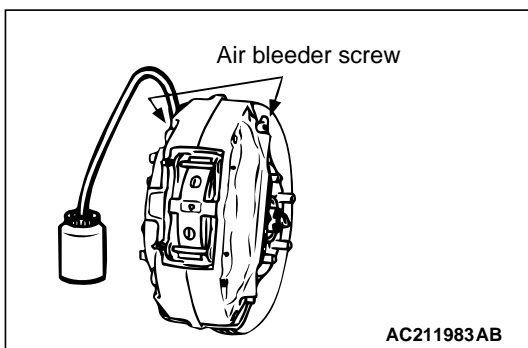

BRAKE LINE BLEEDING

⚠ CAUTION

Be sure to filter/strain the brake fluid being added to the master cylinder reservoir tank. Debris may damage the hydraulic unit.

Start the engine and bleed the air in the sequence shown in the figure.

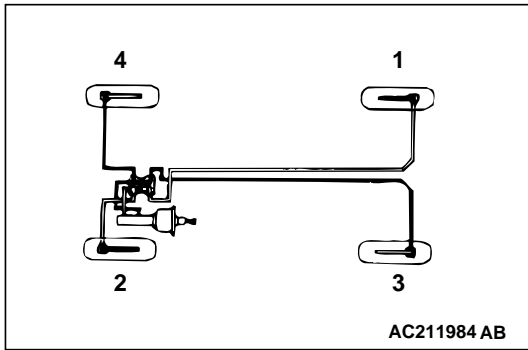

BRAKE FLUID LEVEL SENSOR CHECK

M1351009100317

The brake fluid level sensor is in good condition if there is no continuity when the float surface is above "MIN" and if there is continuity when the float surface is below "MIN".

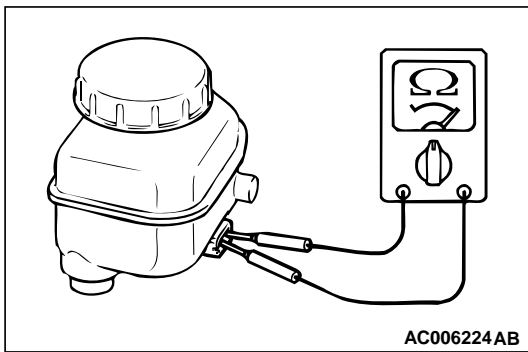

FRONT DISC BRAKE PAD CHECK AND REPLACEMENT

M1351002300309

Required Special Tools:

- MB990520: Piston Expander

NOTE: The brake pads have indicators that contact the brake disc when the brake pad thickness becomes 2 mm (0.08 inch), and emit a squealing sound to warn the driver.

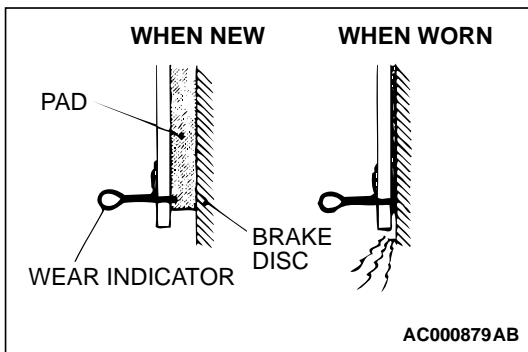

⚠ CAUTION

- Take care not to contact the parts or tools to the caliper because the paint of caliper will be scratched. And if there is brake fluid on the caliper, wipe out quickly.
- Whenever a pad must be replaced, replace both LH and RH wheel pads as a set to prevent the vehicle from pulling to one side when braking.
- If there is a significant difference in the thicknesses of the pads on the left and right sides, check moving parts.

1. Check the brake pad thickness through the caliper body check port.

Standard value:

<Front> 10.0 mm (0.39 inch)

<Rear> 9.0 mm (0.35 inch)

Minimum limit: 2.0 mm (0.08 inch)

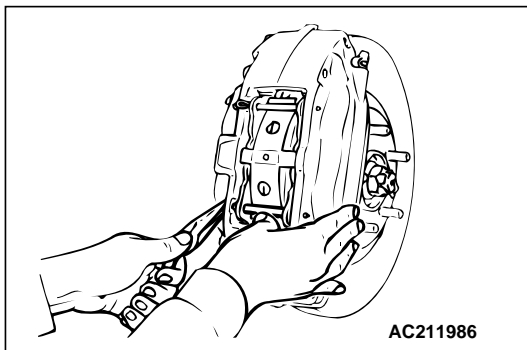
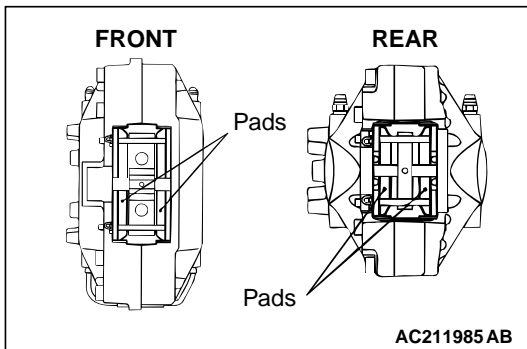

2. When the thickness is less than the limit, always replace the pads at an axle set.

- (1) Holding the cross spring with one hand, pull the pin out of the caliper.

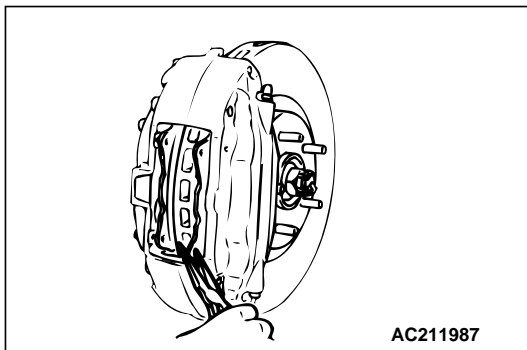

- (2) Remove the pad from the caliper.

- (3) To measure brake drag force after new pads have been installed, use a spring scale to measure the turning sliding resistance of the hub with the pads removed.

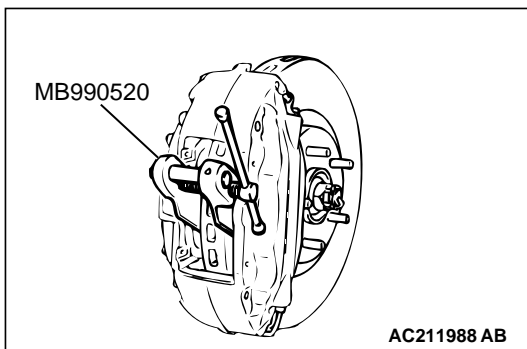

- (4) Clean the piston and, using special tool MB990520, push the piston into the cylinder.

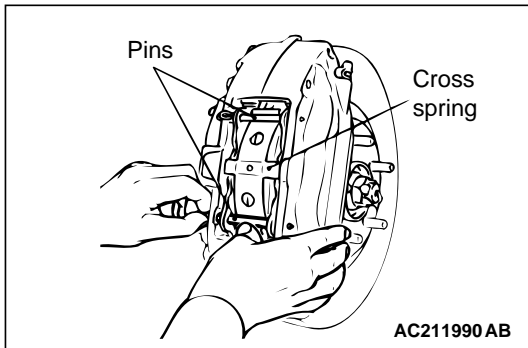
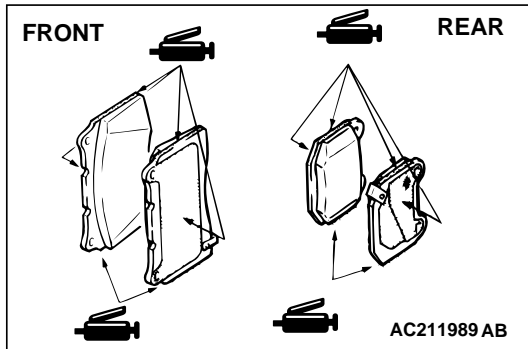

- (5) Apply repair kit grease to the portions of the pads indicated on the left. At this time, make sure that the grease will not be applied to any other surfaces.
- (6) Mount the pads to the caliper so that its side with the wear indicator is on the outside of the vehicle. With the rear pads, ensure that the arrow on the pad faces in the same direction as the brake disc turns when the vehicle moves forward.

- (7) Holding the cross spring with one hand, fit pins in the caliper.
- (8) Using a spring scale, measure the turning sliding resistance of the hub in the forward direction.
- (9) Find the brake disc drag force [the difference in measurements taken in step(3) and in step(8)].

Standard value: 69 N (15 pounds) or less

- (10) If that drag force exceeds the standard value, disassemble the caliper assembly. Then check the piston for contamination or rust, and confirm if the piston or the piston seal is deteriorated.

DISC BRAKE ROTOR CHECK

M1351002900259

⚠ CAUTION

Disc brakes must be kept within the allowable service values in order to maintain normal brake operation.

Before turning the brake disc, the following conditions should be checked.

INSPECTION ITEMS	REMARKS
Scratches, rust, saturated lining materials and wear	<ul style="list-style-type: none"> • If the vehicle is not driven for a long period of time, sections of the discs that are not in contact with the pads will become rusty, causing noise and shuddering. • If grooves and scratches resulting from excessive disc wear are not removed prior to installing a new pad assembly, there will be inadequate contact between the disc and the lining (pad) until the pads conform to the disc.
Run-out	Excessive run-out of the discs will increase the pedal depression resistance due to piston kick-back.
Change in thickness (parallelism)	If the thickness of the disc changes, this will cause pedal pulsation, shuddering and surging.
Inset or warping (flatness)	Overheating and improper handling while servicing will cause warping or distortion.

BRAKE DISC THICKNESS CHECK

M1351002400339

⚠ CAUTION

Take care not to contact the parts or tools to the caliper because the paint of caliper will be scratched. And if there is brake fluid on the caliper, wipe out quickly.

1. Using a micrometer, measure disc thickness at eight positions, approximately 45 degrees apart and 10 mm (0.39 inch) in from the outer edge of the disc.

Standard value:

<Front> 32.0 mm (1.26 inch)

<Rear> 22.0 mm (0.87 inch)

Minimum limit:

<Front> 29.8 mm (1.17 inch)

<Rear> 20.4 mm (0.80 inch)

NOTE: Thickness variation (at least 8 positions) should not be more than 0.015 mm (0.0006 inch).

2. If the disc thickness is less than the limits, replace it with a new one.

⚠ CAUTION

- After a new brake disc is installed, always grind the brake disc with on-the-car type brake lathe. If this step is not carried out, the brake disc run-out exceeds the specified value, resulting in judder.
- When the on-the-car type lathe is used, first install M12 flat washer on the stud bolt in the brake disc side according to the figure, and then install the adapter. If the adapter is installed with M12 flat washer not seated, the brake disc rotor may be deformed, resulting in inaccurate grinding.
- Grind the brake disc with all wheel nuts diagonally and equally tightened to the specified torque 100 N·m (74 ft·lb). When all numbers of wheel nuts are not used, or the tightening torque is excessive or not equal, the brake disc rotor or drum may be deformed, resulting in judder.

3. If thickness variation exceeds the specification, turn rotor with an on-the-car type brake lathe ("Accuturn-8750" or equivalent).

If the calculated final thickness after turning the rotor is less than the standard value, replace the disc.

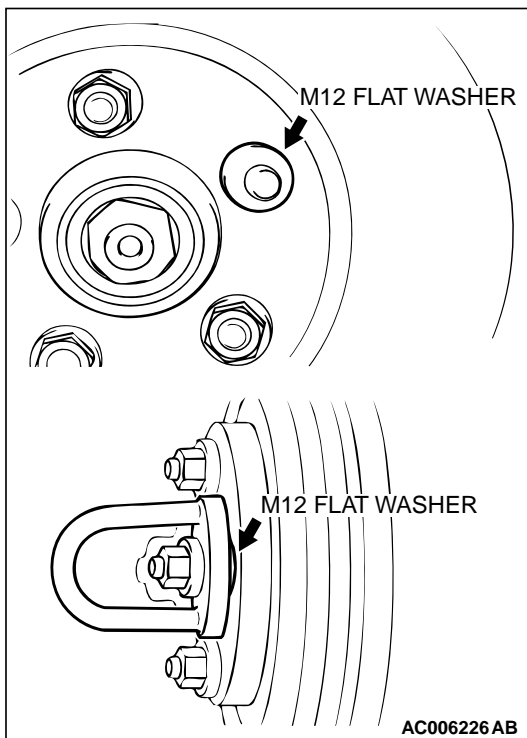
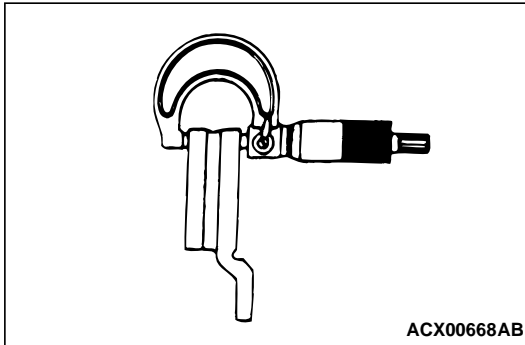

BRAKE DISC RUN-OUT CHECK AND CORRECTION

M1351009400437

⚠ CAUTION

Take care not to contact the parts or tools to the caliper because the paint of caliper will be scratched. And if there is brake fluid on the caliper, wipe out quickly.

1. Remove the brake assembly, and then hold it with wire.
2. Temporarily install the disc with the hub nut.
3. Place a dial gauge approximately 5 mm from the outer circumference of the brake disc, and measure the run-out of the disc.

Limit: 0.03 mm (0.0012 inch)

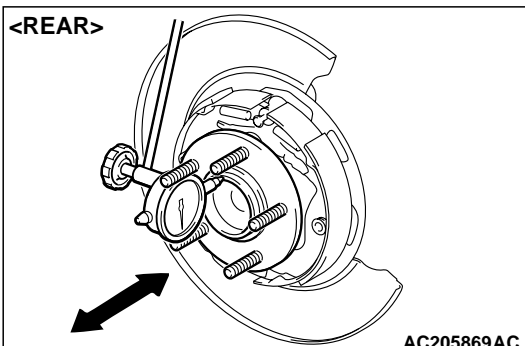
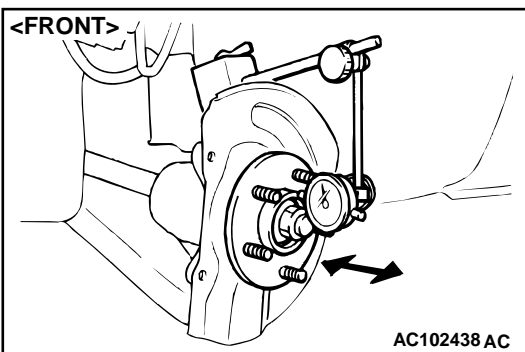
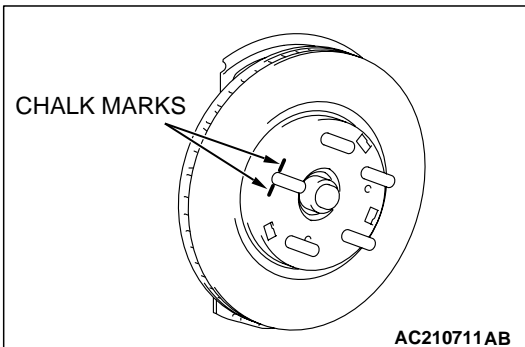
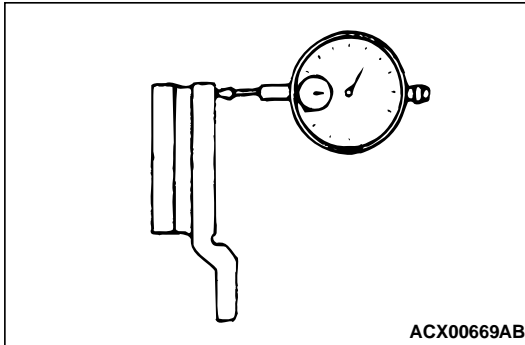

4. If the brake disc run-out exceeds the limit, correct it as follows:
 - (1) Chalk phase marks on the wheel stud and the brake disc, which run-out is excessive as shown.

- (2) Remove the brake disc. Then place a dial gauge as shown, and measure the end play by pushing and pulling the wheel hub.

Limit: 0.05 mm (0.002 inch)

- (3) If the end play exceeds the limit, disassemble the hub and knuckle assembly to check each part.
- (4) If the end play does not exceed the limit, dephase the brake disc and secure it. Then recheck the brake disc run-out.

⚠ CAUTION

- After a new brake disc is installed, always grind the brake disc with on-the-car type brake lathe. If this step is not carried out, the brake disc run-out exceeds the specified value, resulting in judder.
 - When the on-the-car type lathe is used, first install M12 flat washer on the stud bolt in the brake disc side according to the figure, and then install the adapter. If the adapter is installed with M12 flat washer not seated, the brake disc rotor may be deformed, resulting in inaccurate grinding.
 - Grind the brake disc with all wheel nuts diagonally and equally tightened to the specified torque 100 N·m (74 ft·lb). When all numbers of wheel nuts are not used, or the tightening torque is excessive or not equal, the brake disc rotor or drum may be deformed, resulting in judder.
5. If the run-out cannot be corrected by changing the phase of the brake disc, replace the brake disc or grind it with the on-the-car type brake lathe ("Accuturn-8750" or equivalent).

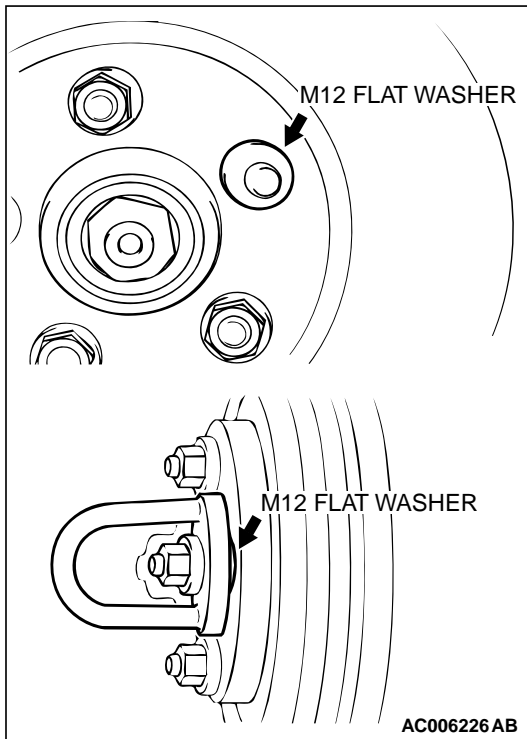

MASTER CYLINDER FUNCTION CHECK

M1351010200200

1. Remove the reservoir cap and diaphragm.
2. While watching the open reservoir from a distance of 50 cm (20 inches), have an assistant depress the brake pedal.
If there was a stream of brake fluid rising from the reservoir, proceed to Step 3.
If there was no stream of brake fluid rising from the reservoir, repair or replace the master cylinder.
3. While watching the open reservoir from a distance of 50 cm (20 inches), have the assistant release the brake pedal.
If there was a small amount of air bubbles rising through the brake fluid, master cylinder function is normal.
If there were no bubbles rising through the brake fluid, repair or replace the master cylinder.

BRAKE PEDAL

REMOVAL AND INSTALLATION

M1351003400310

Post-installation Operation

- Brake Pedal Adjustment (Refer to P.35A-12.)

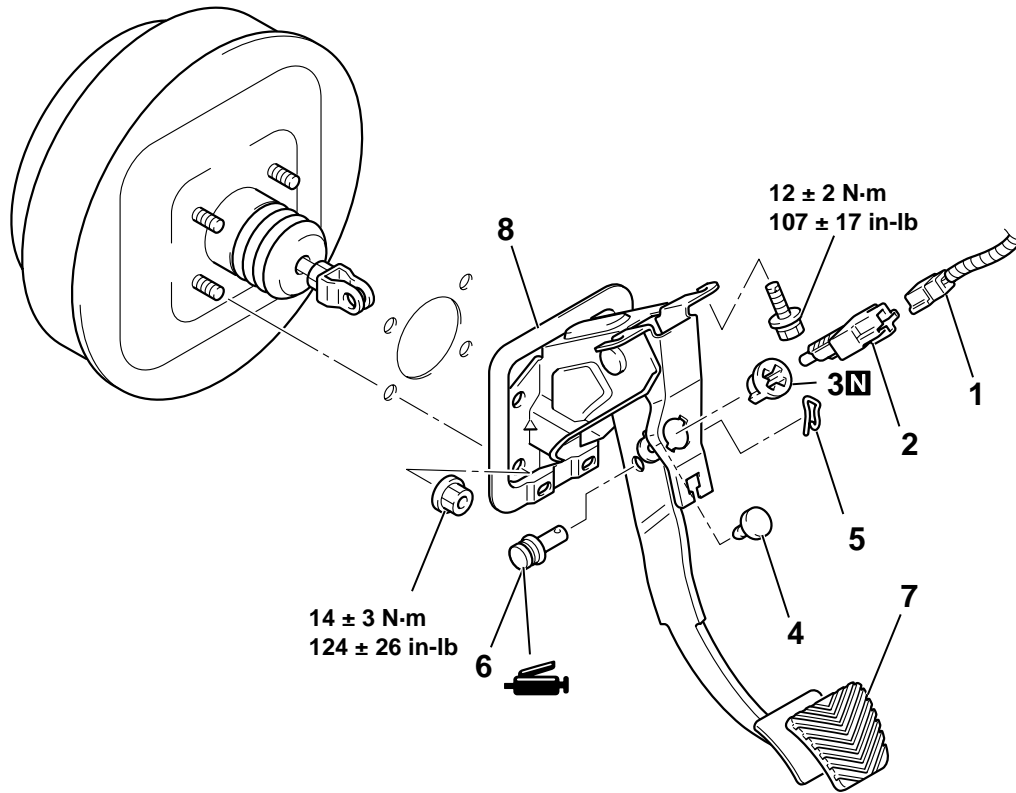

AC211554 AB

REMOVAL STEPS

1. HARNESS CONNECTOR
2. STOPLIGHT SWITCH
3. BRAKE PEDAL CLIP
4. BRAKE PEDAL STOPPER

REMOVAL STEPS (Continued)

5. BRAKE BOOSTER PIN
6. BRAKE PIN ASSEMBLY
7. BRAKE PEDAL PAD
- >>A<< 8. BRAKE PEDAL ASSEMBLY

INSTALLATION SERVICE POINT

>>A<< BRAKE PEDAL ASSEMBLY INSTALLATION

Tighten the brake booster mounting nuts (A), and then the brake pedal assembly mounting bolts (B).

NOTE: The brake pedal assembly can not be positioned correctly if the brake pedal assembly mounting bolts (B) are tightened first as the their holes are oblong holes.

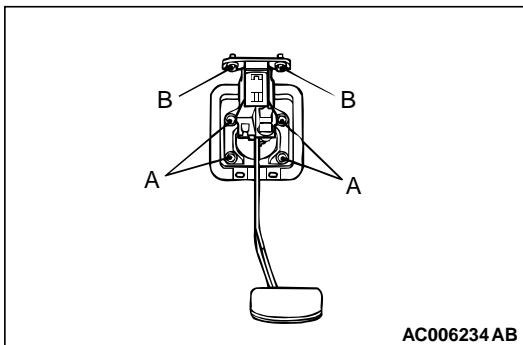

INSPECTION

M1351003500146

STOPLIGHT SWITCH CHECK

1. Connect an ohmmeter between the stoplight switch connector terminals.
2. There should be no continuity between the terminals when the plunger is pushed in as shown. There should be continuity when it is released.

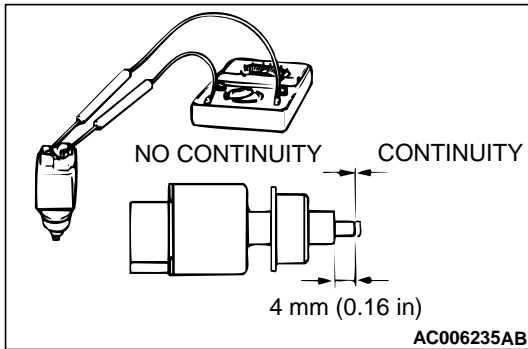

MASTER CYLINDER ASSEMBLY AND BRAKE BOOSTER REMOVAL AND INSTALLATION

M1351003700311

<p>Pre-removal Operation</p> <ul style="list-style-type: none"> • Brake Fluid Draining • Air Intake Hose and Air Cleaner Removal (Refer to GROUP 15, Air Cleaner P.15-7.) • Strut Tower Bar Removal (Refer to GROUP 42, Strut Tower Bar P.42-12.) 	<p>Post-installation Operation</p> <ul style="list-style-type: none"> • Brake Pedal Adjustment (Refer to P.35A-12.) • Air Intake Hose and Air Cleaner Installation (Refer to GROUP 15, Air Cleaner P.15-7.) • Strut Tower Bar Removal (Refer to GROUP 42, Strut Tower Bar P.42-12.) • Brake Fluid Supplying and Air Bleeding (Refer to P.35A-15.)
---	--

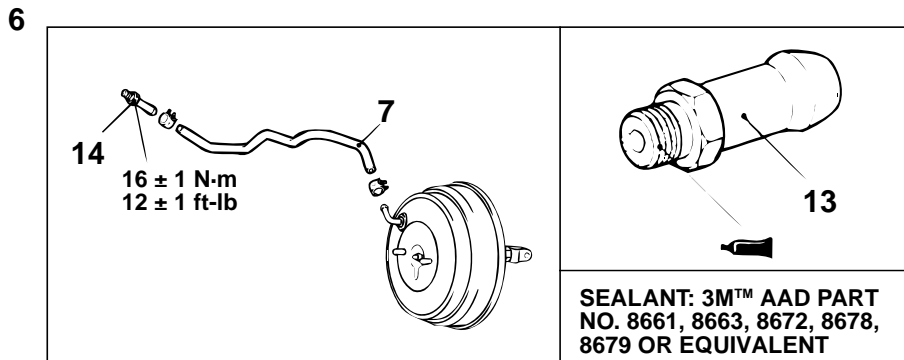
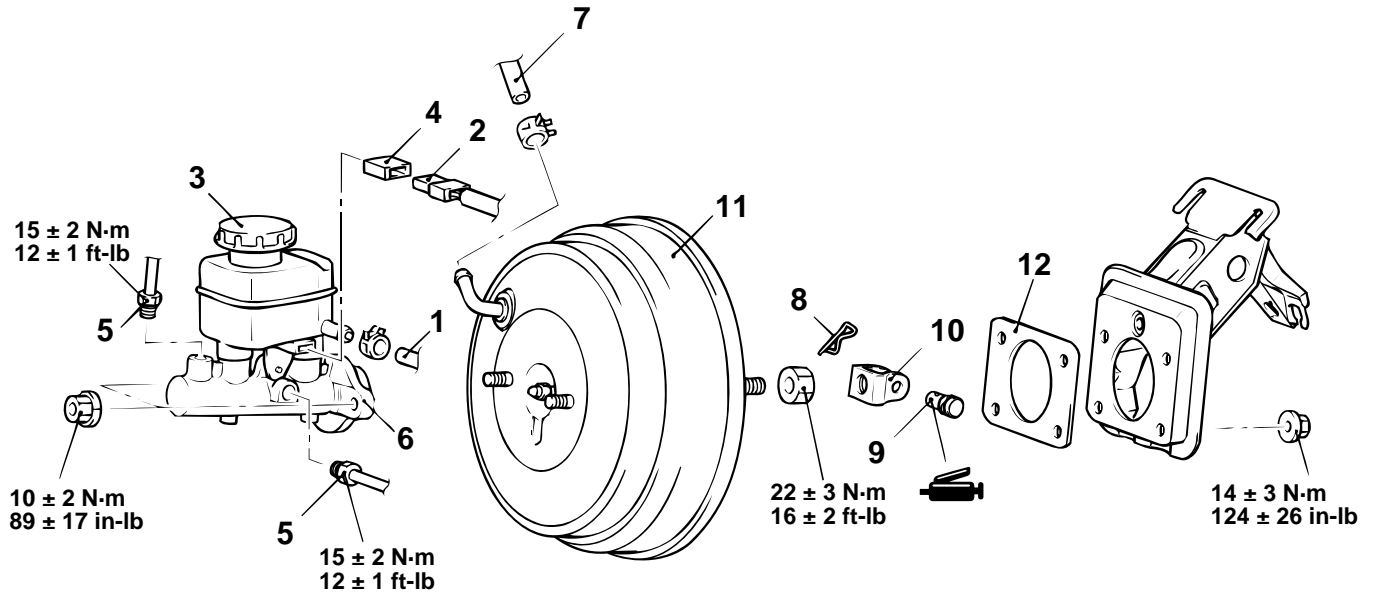

AC211993 AB

MASTER CYLINDER REMOVAL STEPS

1. CLUTCH HOSE CONNECTION
2. BRAKE FLUID LEVEL INDICATOR SWITCH CONNECTOR
3. BRAKE FLUID RESERVOIR CAP
4. BRAKE FLUID LEVEL INDICATOR SWITCH
5. BRAKE TUBE CONNECTION
6. BRAKE MASTER CYLINDER ASSEMBLY

BRAKE BOOSTER REMOVAL STEPS

1. CLUTCH HOSE CONNECTION
 2. BRAKE FLUID LEVEL INDICATOR SWITCH CONNECTOR
 5. BRAKE TUBE CONNECTION
 6. BRAKE MASTER CYLINDER ASSEMBLY
- >>B<<
- PUSH ROD PROTRUSION AMOUNT CHECK AND ADJUSTMENT

**BRAKE BOOSTER REMOVAL
STEPS (Continued)**

- >>A<< 7. BRAKE BOOSTER VACUUM HOSE (WITH BUILT-IN CHECK VALVE)
- 8. BRAKE BOOSTER PIN
- 9. BRAKE BOOSTER PIN ASSEMBLY
- 10. CLEVIS
 - REMOVE A/C LIQUID PIPE B FROM THE RETAINING CLIP. (REFER TO GROUP 55A, REFRIGERANT LINE.)
- 11. BRAKE BOOSTER ASSEMBLY
- 12. BRAKE BOOSTER BODY SEAL

FITTING REMOVAL STEPS

- >>A<< 7. BRAKE BOOSTER VACUUM HOSE (WITH BUILT-IN CHECK VALVE)
- 13. BRAKE BOOSTER VACUUM HOSE FITTING

Required Special Tools:

- MB991568: Push Rod Adjusting Socket

INSTALLATION SERVICE POINTS

>>A<< BRAKE BOOSTER VACUUM HOSE CONNECTION

Insert the brake booster vacuum hose to the brake booster assembly with its paint mark facing upward, and then secure the hose by using the hose clip.

>>B<< PUSH ROD PROTRUSION AMOUNT CHECK AND ADJUSTMENT

- 1. Measure dimension (A).

Standard value (A): 8.98 – 9.23 mm (0.354 – 0.363 in)

NOTE: When a negative pressure of 66.7 kPa (19.7 inHg) is applied to the brake booster, the push rod should protrude 10.27 - 10.53 mm (0.404 – 0.414 in).

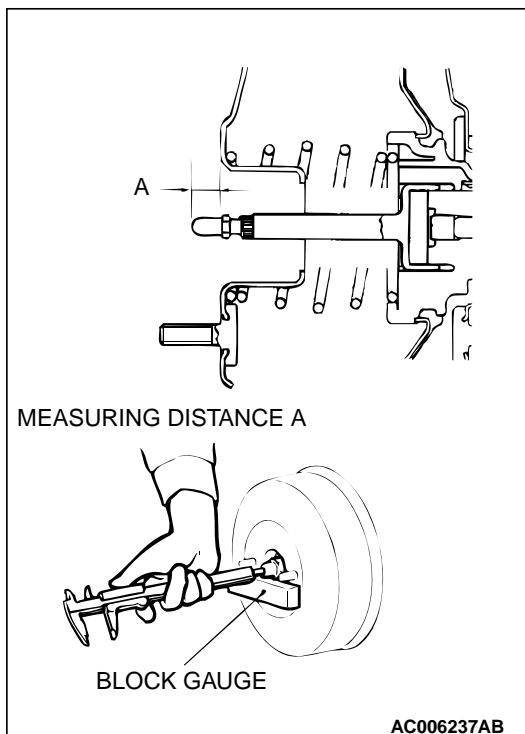

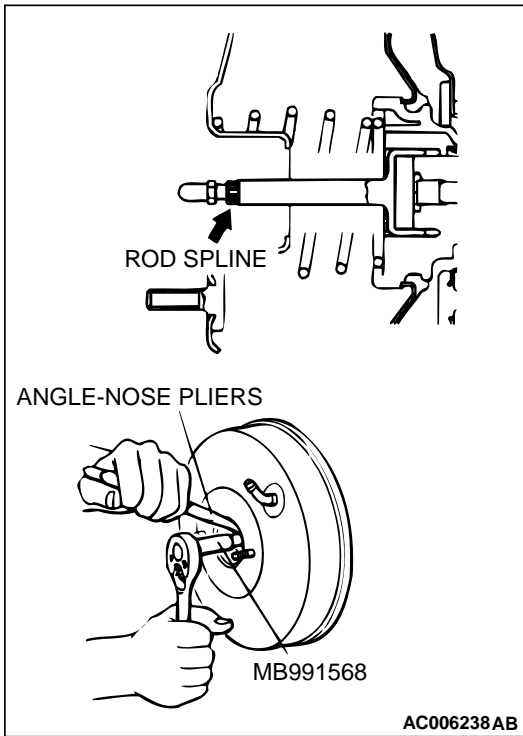

- If the protrusion amount is not within the standard value range, adjust the push rod length by turning the push rod. Use special tool MB991568 to turn the push rod while holding the rod spline with angle-nose pliers.

**MASTER CYLINDER
DISASSEMBLY AND ASSEMBLY**

M1351004200278

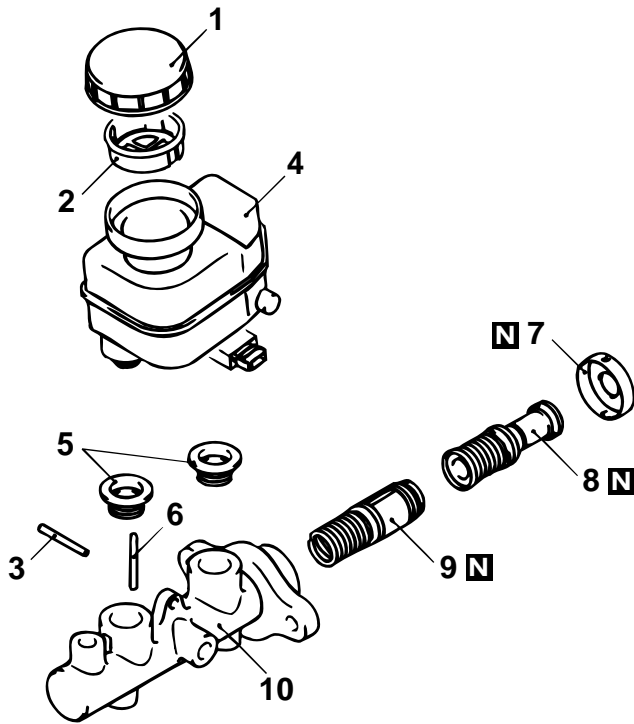

DISASSEMBLY STEPS

- BRAKE FLUID RESERVOIR CAP
- BRAKE FLUID RESERVOIR FILTER
- BRAKE MASTER CYLINDER PIN
- BRAKE FLUID RESERVOIR

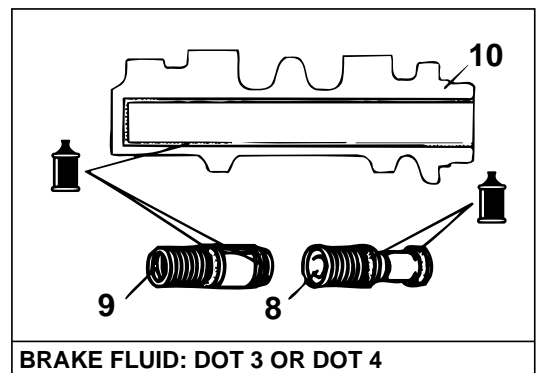
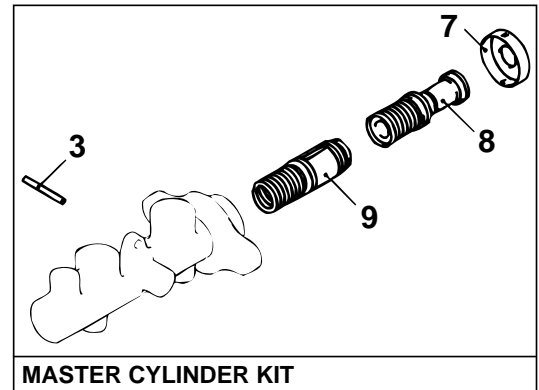

DISASSEMBLY STEPS (Continued)

- BRAKE MASTER CYLINDER TO RESERVOIR SEAL
- BRAKE MASTER CYLINDER PIN
- PISTON RETAINER

DISASSEMBLY STEPS (Continued)

8. PRIMARY PISTON ASSEMBLY
9. SECONDARY PISTON ASSEMBLY
10. MASTER CYLINDER BODY

INSPECTION

M1351004300208

- Check the inner surface of master cylinder body for rust or pitting.
- Check the primary and secondary pistons for rust, scoring, wear or damage.
- Check the diaphragm for cracks and wear.

FRONT DISC BRAKE ASSEMBLY

REMOVAL AND INSTALLATION

M1351006000322

⚠ CAUTION

Take care not to contact the parts or tools to the caliper because the paint of caliper will be scratched. And if there is brake fluid on the caliper, wipe out quickly.

Pre-removal Operation

- Brake Fluid Draining

Post-installation Operation

- Brake Fluid Supplying and Air Bleeding (Refer to [P.35A-15.](#))

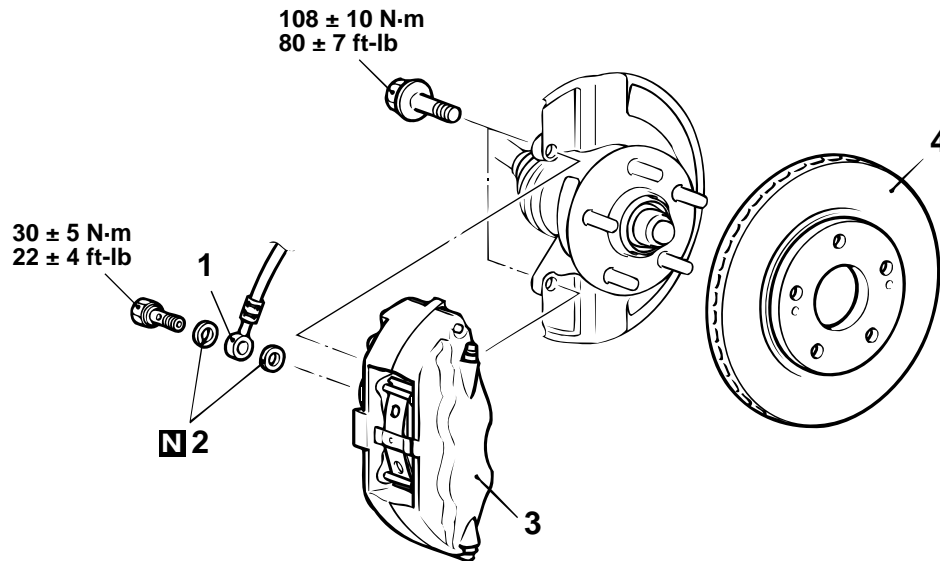

AC211991 AB

REMOVAL STEPS

1. BRAKE HOSE CONNECTION
2. GASKET

REMOVAL STEPS (Continued)

- >>A<<
3. DISC BRAKE ASSEMBLY
 4. BRAKE DISC

INSTALLATION SERVICE POINT**>>A<< DISC BRAKE ASSEMBLY INSTALLATION**

1. Find the drag force of the disc brake (Refer to [P.35A-16](#)).
Standard value: 69 (15 pound) or less
2. If that drag force exceeds the standard value, disassemble the caliper assembly. Then check the piston for contamination or rust, and confirm if the piston or the piston seal is deteriorated.

INSPECTION

M1351006100222

BRAKE DISC CHECK

- Disc wear (Refer to [P.35A-19](#).)
Disc run-out (Refer to [P.35A-20](#).)

DISASSEMBLY AND ASSEMBLY

CAUTION

Take care not to contact the parts or tools to the caliper because the paint of caliper will be scratched. And if there is brake fluid on the caliper, wipe out quickly.

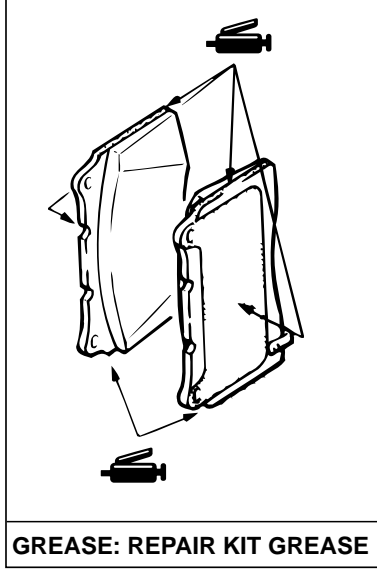
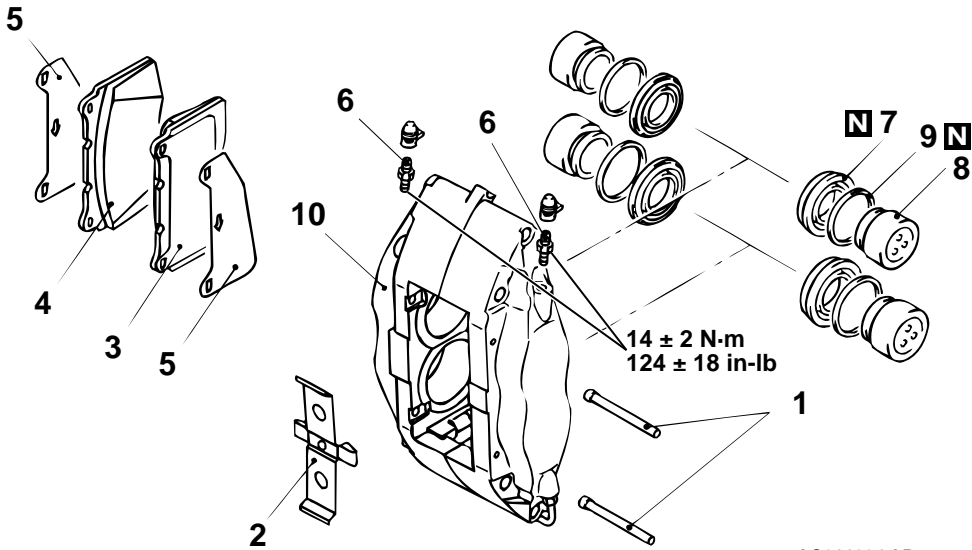

AC211994 AB

<p>BRAKE CALIPER KIT</p>	<p>SEAL AND BOOT REPAIR KIT</p>	<p>SHIM SET</p>
<p>CLIP SET</p>	<p>PAD SET</p>	

DISASSEMBLY STEPS

1. PIN
2. PAD ANTI-SQUEAK SPRING <<A>>
3. PAD AND WEAR INDICATOR ASSEMBLY <<A>>
<>
4. PAD ASSEMBLY
5. SHIM

DISASSEMBLY STEPS (Continued)

6. CALIPER BLEEDER
7. PISTON BOOT
8. PISTON
9. PISTON SEAL
10. CALIPER BODY

DISASSEMBLY SERVICE POINTS

⚠ CAUTION

Take care not to contact the parts or tools to the caliper because the paint of caliper will be scratched. And if there is brake fluid on the caliper, wipe out quickly.

When disassembling the disc brakes, disassemble both sides (left and right) as a set.

<<A>> PISTON BOOT/PISTON REMOVAL

⚠ CAUTION

Do not remove one piston completely before trying to remove the other piston, because it will become impossible to remove other pistons.

Remove the pistons by pumping in air slowly from the brake hose connection. Be sure to use a wood block and adjust the height of the four pistons while so that the pistons protrude evenly.

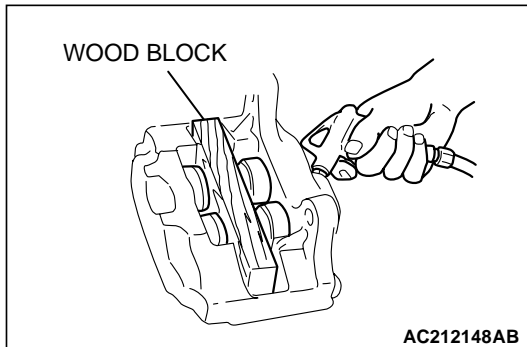

<> PISTON SEAL REMOVAL

⚠ CAUTION

Do not use a flat-tipped screwdriver or other tool to prevent damage to inner cylinder.

1. Remove the piston seal with finger tip.
2. Clean the piston surface and inner cylinder with alcohol or brake fluid DOT 3 or DOT 4.

INSPECTION

M1351006300293

- Check the cylinder for wear, damage or rust.
- Check the piston surface for wear, damage or rust.
- Check the caliper body for wear.
- Check the pad for damage or adhesion of grease, check the backing metal for damage.

PAD WEAR CHECK

⚠ WARNING

- Always replace both brake pads on each wheel as a set (both front wheels or both rear wheels). Failure to do so will result in uneven braking, which may cause unreliable brake operation.
- If there is significant difference in the thickness of the pads on the left and right sides, check moving parts.

Measure thickness at the thinnest and most worn area of the pad.

Replace the pad assembly if pad thickness is less than the limit value.

Standard value: 10.0 mm (0.39 inch)

Minimum limit: 2.0 mm (0.08 inch)

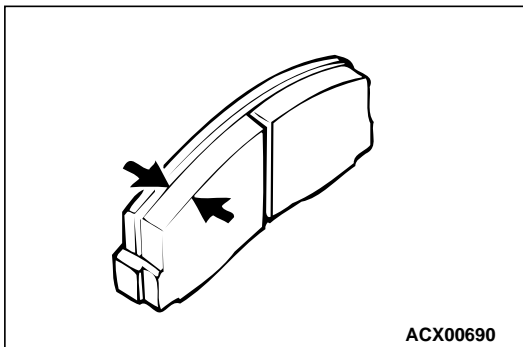

REAR DISC BRAKE ASSEMBLY

REMOVAL AND INSTALLATION

M1351007000217

⚠ CAUTION

Take care not to contact the parts or tools to the caliper because the paint of caliper will be scratched. And if there is brake fluid on the caliper, wipe out quickly.

Pre-removal Operation

- Brake Fluid Draining

Post-installation Operation

- Brake Fluid Filling and Air Bleeding (Refer to [P.35A-15.](#))

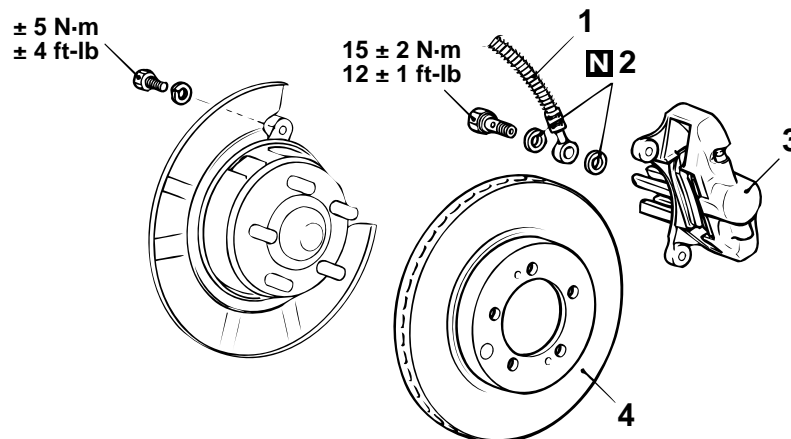

AC211992AB

REMOVAL STEPS

1. BRAKE HOSE CONNECTION
2. GASKET

>>A<<

REMOVAL STEPS (Continued)

3. DISC BRAKE ASSEMBLY
4. BRAKE DISC

INSTALLATION SERVICE POINT**>>A<< DISC BRAKE ASSEMBLY INSTALLATION**

1. Find the drag force of the disc brake (Refer to [P.35A-16](#)).
Standard value: 69 N (15 pound) or less
2. If that drag force exceeds the standard value, disassemble the caliper assembly. Then check the piston for contamination or rust, and confirm if the piston or the piston seal is deteriorated.

INSPECTION

M1351007100214

BRAKE DISC CHECKDisc wear: Refer to [P.35A-19](#).Disc run-out: Refer to [P.35A-20](#).

DISASSEMBLY AND ASSEMBLY

M1351007200211

⚠ CAUTION

Take care not to contact the parts or tools to the caliper because the paint of caliper will be scratched. And if there is brake fluid on the caliper, wipe out quickly.

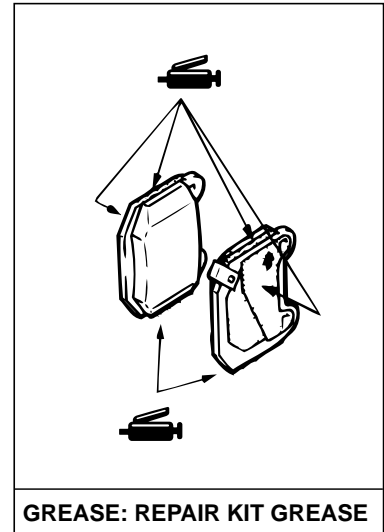
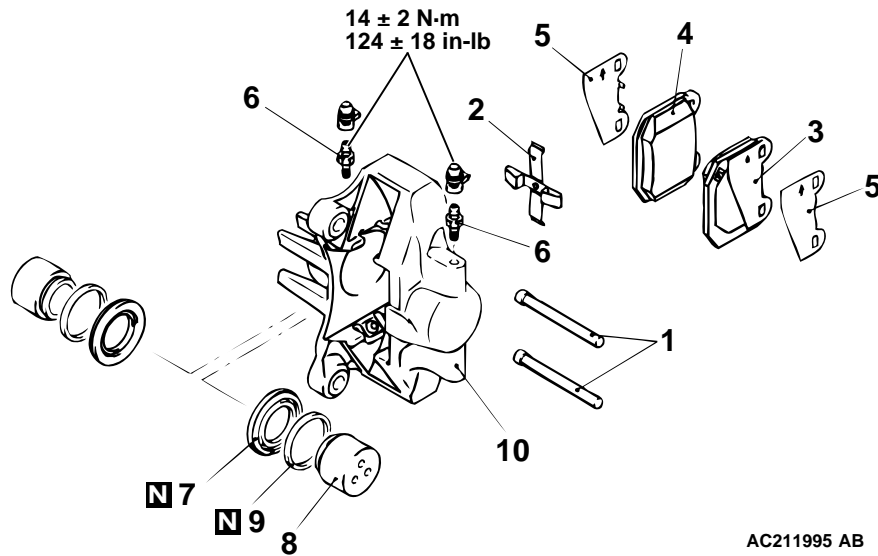

AC211995 AB

BRAKE CALIPER KIT	SEAL AND BOOT REPAIR KIT	SHIM SET
CLIP SET	PAD SET	

DISASSEMBLY STEPS

1. PIN
2. PAD ANTI-SQUEAK SPRING

DISASSEMBLY STEPS (Continued)

3. PAD AND WEAR INDICATOR ASSEMBLY
4. PAD ASSEMBLY

DISASSEMBLY STEPS (Continued)

- <<A>> 5. SHIM
<<A>> 6. CALIPER BLEEDER
<> 7. PISTON BOOT
<<A>> 8. PISTON
<> 9. PISTON SEAL
10. CALIPER BODY

DISASSEMBLY SERVICE POINTS

⚠ CAUTION

Take care not to contact the parts or tools to the caliper because the paint of caliper will be scratched. And if there is brake fluid on the caliper, wipe out quickly.

When disassembling the disc brakes, disassemble both sides (left and right) as a set.

<<A>> PISTON BOOT/PISTON REMOVAL

Remove the pistons by pumping in air slowly from the brake hose connection. Be sure to use a wood block and adjust the height of the two pistons while so that the pistons protrude evenly.

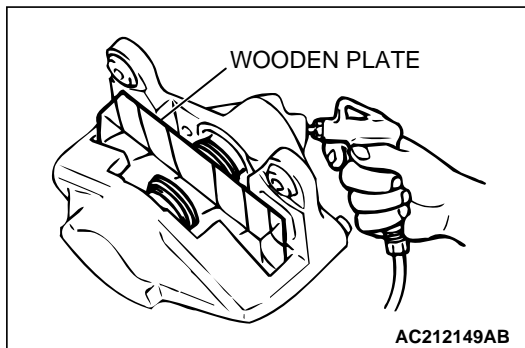

<> PISTON SEAL REMOVAL

⚠ CAUTION

Do not use a flat-tipped screwdriver or other tool to prevent damage to inner cylinder.

1. Remove the piston seal with finger tip.
2. Clean the piston surface and inner cylinder with alcohol or brake fluid DOT 3 or DOT 4.

INSPECTION

M1351007300207

- Check the cylinder for wear, damage or rust.
- Check the piston surface for wear, damage or rust.
- Check the caliper body for wear.
- Check the pad for damage or adhesion of grease, check the backing metal for damage.

PAD WEAR CHECK

⚠ WARNING

- *Always replace both brake pads on each wheel as a set (both front wheels or both rear wheels). Failure to do so will result in uneven braking, which may cause unreliable brake operation.*
- *If there is significant difference in the thickness of the pads on the left and right sides, check moving parts.*

Measure thickness at the thinnest and most worn area of the pad.

Replace the pad assembly if pad thickness is less than the limit value.

Standard value: 9.0 mm (0.35 inch)

Minimum limit: 2.0 mm (0.08 inch)

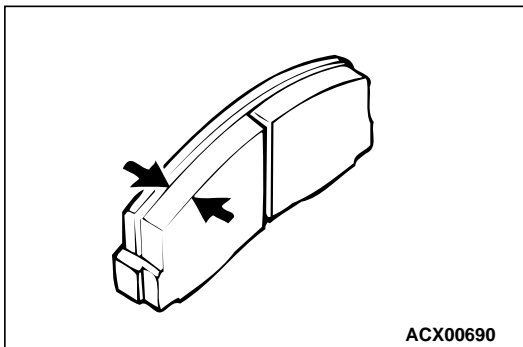

SPECIFICATIONS

FASTENER TIGHTENING SPECIFICATIONS

M1351009600345

ITEMS	SPECIFICATIONS
Brake line	
Brake tube flare nut	15 ± 2 N·m (12 ± 1 ft-lb)
Brake pedal	
Brake pedal assembly bolt	12 ± 2 N·m (107 ± 17 in-lb)
Brake pedal assembly nut	14 ± 3 N·m (124 ± 26 in-lb)
Front disc brake	
Brake hose connector bolt	30 ± 5 N·m (22 ± 4 ft-lb)
Caliper bleeder	14 ± 2 N·m (124 ± 18 in-lb)
Front brake assembly mounting bolt	108 ± 10 N·m (80 ± 7 ft-lb)
Master cylinder assembly and brake booster	
Brake booster mounting nut	14 ± 3 N·m (124 ± 26 in-lb)
Fitting	16 ± 1 N·m (12 ± 1 ft-lb)
Master cylinder mounting nut	10 ± 2 N·m (89 ± 17 in-lb)
Operating rod jam nut	22 ± 3 N·m (16 ± 2 ft-lb)
Rear disc brake	
Brake hose connector bolt	15 ± 2 N·m (12 ± 1 ft-lb)
Caliper bleeder	14 ± 2 N·m (124 ± 18 in-lb)
Rear brake assembly mounting bolt	54 ± 5 N·m (40 ± 4 ft-lb)

GENERAL SPECIFICATIONS

M1351000200317

ITEM		SPECIFICATION
Master cylinder	Type	Tandem type
	I.D. mm (in)	26.9 (1.06)
Brake booster	Type	Vacuum type, tandem
	Effective dia. of power cylinder mm (in)	205 + 230 (8 + 9)
	Boosting ratio	4.5 <Brake pedal depressing force: 230 N (51.7 lb)>
Rear wheel hydraulic control method		Electronic brake-force distribution (EBD)
Front brakes	Type	4-opposed piston, ventilated disc
	Disc effective dia. × thickness mm (in)	263 × 32 (10.4 × 1.3)
	Wheel cylinder I.D. mm (in)	40.0 (1.58) × 2, 46.0 (1.81) × 2
	Pad thickness mm (in)	10.0 (0.39)
	Clearance adjustment	Automatic
Rear brakes	Type	2-opposed piston, ventilated disc
	Disc effective dia. × thickness mm (in)	252 × 22 (9.9 × 0.9)
	Wheel cylinder I.D. mm (in)	40.0 (1.58) × 2
	Pad thickness mm (in)	9.0 (0.35)
	Clearance adjustment	Automatic

SERVICE SPECIFICATIONS

M1351000300392

ITEM	STANDARD VALUE	LIMIT
Brake pedal height mm (in)	169.1 – 172.1 (6.7 – 6.8)	–
Brake pedal free play mm (in)	3 – 8 (0.12 – 0.31)	–
Brake pedal to floor board clearance mm (in)	90 (3.5) or more	–
Front disc brake pad thickness mm (in)	10.0 (0.39)	Minimum 2.0 (0.08)
Front disc brake disc thickness mm (in)	32.0 (1.26)	Minimum 29.8 (1.17)
Front disc brake disc run-out mm (in)	–	0.03 (0.0012)
Front disc brake drags force N (lb)	69 (15) or less	–
Rear disc brake pad thickness mm (in)	9.0 (0.35)	Minimum 2.0 (0.08)
Rear disc brake disc thickness mm (in)	22.0 (0.87)	Minimum 20.4 (0.80)
Rear disc brake disc run-out mm (in)	–	0.03 (0.0012)
Rear disc brake drags force N (lb)	69 (15) or less	–
Front wheel bearing axial play mm (in)	–	0.05 (0.002)
Rear wheel bearing axial play mm (in)	–	0.05 (0.002)
Brake booster push rod protruding amount mm (in)	8.98 – 9.23 (0.354 – 0.363)	–

LUBRICANTS

M1351000400333

ITEM	SPECIFIED LUBRICANT
Brake fluid	DOT3 or DOT4
Pad assembly	Repair kit grease

SEALANT

M1351000500288

ITEM	SPECIFIED SEALANT	REMARK
Fitting	3M™ AAD Part No. 8661, 8663, 8672, 8678, 8679 or equivalent	Semi-drying sealant

NOTES