

GROUP 13B**FUEL SUPPLY****CONTENTS**

GENERAL INFORMATION	13B-2	FUEL PUMP OPERATION CHECK	13B-6
FUEL SUPPLY DIAGNOSIS	13B-2	FUEL LEVEL SENSOR (SUB) CHECK.	13B-6
INTRODUCTION.....	13B-2	FUEL PUMP MODULE REPLACEMENT ..	13B-6
TROUBLESHOOTING STRATEGY	13B-2	FUEL LEVEL SENSOR (SUB)	
SYMPTOM PROCEDURES	13B-3	REPLACEMENT	13B-9
SPECIAL TOOLS	13B-5	FUEL TANK	13B-10
ON-VEHICLE SERVICE	13B-6	REMOVAL AND INSTALLATION	13B-10
		DISASSEMBLY AND ASSEMBLY	13B-15
		DISASSEMBLY AND REASSEMBLY	13B-17
		FUEL TANK INSPECTION	13B-18

GENERAL INFORMATION

M1135000101234

This fuel system is designed with consideration for global environment protection to ensure safety at a collision, reduce weight, and improve reliability and quality. The system has the following features.

- A quick-joint connector of a plastic tube is used for the fuel high-pressure hoses in the engine compartment to reduce the permeation of fuel evaporative emission.

- The surface of underfloor fuel pipes is coated with 1 mm (0.04 inch) thickness of plastic to improve resistance to corrosion and chipping.
- The rubber boot is employed for the filler port mounting part of fuel filler neck to protect fuel filler neck in case of collision.

CONSTRUCTION DIAGRAM

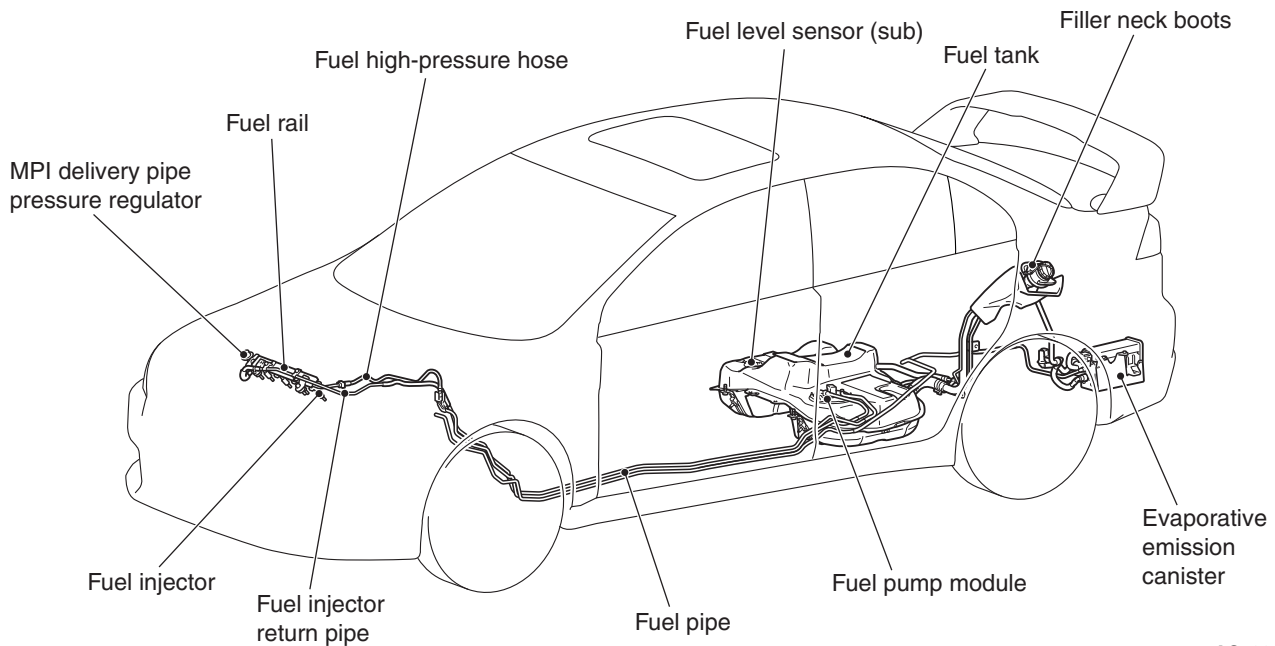

AC709107AC

FUEL SUPPLY DIAGNOSIS

INTRODUCTION

The fuel system is used to supply an appropriate fuel mixture to the engine. The system consists of the fuel tank, fuel filter, fuel pump and fuel pipes. An evaporative emission system is provided to prevent evaporated fuel from escaping into the atmosphere.

TROUBLESHOOTING STRATEGY

Use these steps to plan your diagnostic strategy. If you follow them carefully, you will be sure to find most of the fuel supply faults.

1. Gather information from the customer.

Engine malfunctions caused by insufficient fuel supply and evaporative emission system operation malfunctions can be caused by faults in the vapor line, fuel pipe, hose, or fuel tank pressure control valve, etc.

M1135004000463

2. Verify that the condition described by the customer exists.
3. Find the malfunction by following the Symptom Procedure.
4. Verify malfunction is eliminated.

M1135004100396

SYMPTOM PROCEDURES

M1135004800414

Inspection Procedure 1 : Engine Malfunctions Due to Insufficient Fuel Supply

TROUBLESHOOTING HINTS (The most likely causes for this case:)

- Fuel injector failed.
- Open or shorted fuel injector circuit, or loose connector.
- Bent, twisted or clogged fuel main pipe or fuel high-pressure hose.
- Malfunction of the fuel tank pump and gauge assembly.

DIAGNOSIS

Required Special Tools:

- MB991958: Scan Tool (M.U.T.-III Sub Assembly)
 - MB991824: V.C.I.
 - MB991827: M.U.T.-III USB Cable
 - MB991910: M.U.T.-III Main Harness A

STEP 1. Using scan tool MB991958, read the MFI system diagnostic trouble code.

⚠ CAUTION

To prevent damage to scan tool MB991958, always turn the ignition switch to the "LOCK" (OFF) position before connecting or disconnecting scan tool MB991958.

- (1) Ensure that the ignition switch is at the "LOCK" (OFF) position.
- (2) Start up the personal computer.
- (3) Connect special tool MB991827 to special tool MB991824 and the personal computer.
- (4) Connect special tool MB991910 to special tool MB991824.
- (5) Connect special tool MB991910 to the data link connector.
- (6) Turn the power switch of special tool MB991824 to the "ON" position.

NOTE: When special tool MB991824 is energized, special tool MB991824 indicator light will be illuminated in a green color.

- (7) Start the M.U.T.-III system on the personal computer.
- (8) Turn the ignition switch to the "ON" position.
- (9) Check for MFI system diagnostic trouble code (Refer to GROUP 13A, Diagnostic Function –How to Read and Erase Diagnostic Trouble Codes [P.13A-9](#)).
- (10) Turn the ignition switch to the "LOCK" (OFF) position, and then remove scan tool MB991958 in the reverse order of installation.

Q: Is the DTC set?

YES : Repair MFI system (Refer to GROUP 13A, Diagnostic Trouble Code Chart [P.13A-48](#)). Then go to Step 6.

NO : Go to Step 2.

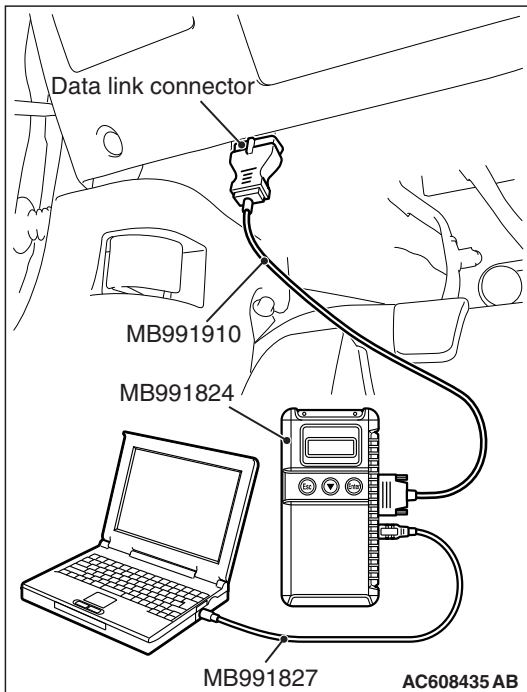

STEP 2. Check the fuel pressure.

Release residual pressure from the fuel line to prevent fuel spray (Refer to GROUP 13A, On-vehicle Service –Fuel Pressure Test [P.13A-865](#)).

Q: Is the fuel pressure in good condition?

YES : Go to Step 5.

NO : Go to Step 3.

STEP 3. Check for bending, twisting or clogging of the fuel main pipe and fuel high-pressure hose.**Q: Are the fuel main pipe and fuel high-pressure hose in good condition?**

YES : Go to Step 4.

NO : Repair or replace the fuel main pipe or fuel high-pressure hose. Then go to Step 6 .

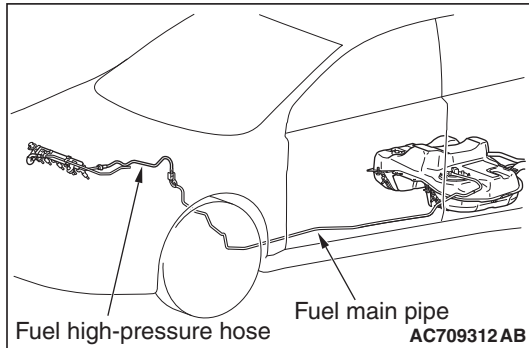
**STEP 4. Check the fuel pump operation.**

Refer to GROUP 13A, On-vehicle Service –Fuel Pump Operation Check [P.13A-869](#).

Q: Is the fuel pump module operation in good condition?

YES : Go to Step 5.

NO : Replace the fuel tank pump and gauge assembly (Refer to [P.13B-6](#)). Then go to Step 6.

STEP 5. Check the inside of the fuel tank for contamination and rust.

Remove the fuel tank (Refer to [P.13B-10](#)).

Q: Is the fuel tank in good condition?

YES : Go to Step 6.

NO : Replace the fuel filter, and clean the fuel tank and fuel line. Then go to Step 6 .

STEP 6. Retest the system.**Q: Is the engine malfunction eliminated?**

YES : The procedure is complete.

NO : Return to Step 1.

SPECIAL TOOLS

M1135000601176

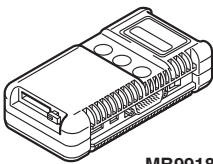
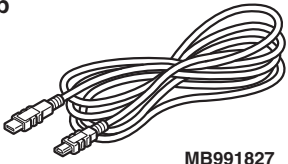
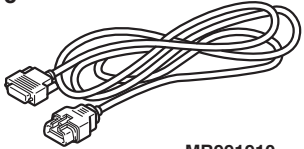
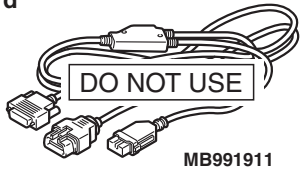
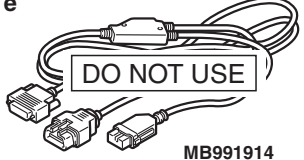
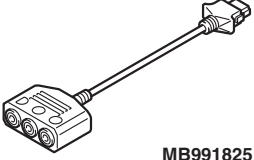
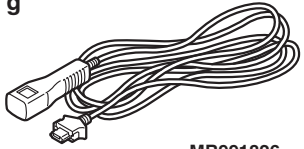
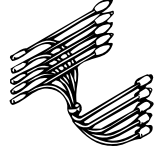
Tool	Tool number and name	Supersession	Application
<p>a</p>  <p>MB991824</p> <p>b</p>  <p>MB991827</p> <p>c</p>  <p>MB991910</p> <p>d</p>  <p>MB991911</p> <p>e</p>  <p>MB991914</p> <p>f</p>  <p>MB991825</p> <p>g</p>  <p>MB991826 MB991958</p>	<p>MB991958 Scan tool (M.U.T.-III sub assembly)</p> <p>a: MB991824 Vehicle communication interface (V.C.I.)</p> <p>b: MB991827 M.U.T.-III USB cable</p> <p>c: MB991910 M.U.T.-III main harness A (Vehicles with CAN communication system)</p> <p>d: MB991911 M.U.T.-III main harness B (Vehicles without CAN communication system)</p> <p>e: MB991914 M.U.T.-III main harness C (for Chrysler models only)</p> <p>f: MB991825 M.U.T.-III adapter harness</p> <p>g: MB991826 M.U.T.-III trigger harness</p>	<p>MB991824-KIT</p> <p><i>NOTE: MB991826 M.U.T.-III Trigger Harness is not necessary when pushing V.C.I. ENTER key.</i></p>	<p>CAUTION</p> <p>For vehicles with CAN communication, use M.U.T.-III main harness A to send simulated vehicle speed. If you connect M.U.T.-III main harness B instead, the CAN communication does not function correctly.</p> <p>Checking diagnostic trouble code</p>
 <p>MB991658</p>	<p>MB991658 Test harness set</p>	<p>Tool not available</p>	<p>Fuel tank differential pressure sensor check</p>

ON-VEHICLE SERVICE**FUEL PUMP OPERATION CHECK**

M1135001000635

Refer to GROUP 13A, On-vehicle Service –Fuel Pump Operation Check [P.13A-869](#).

FUEL LEVEL SENSOR (SUB) CHECK

M1135005300133

Refer to GROUP 54A, Combination Meter –On-vehicle Service, Fuel Level Sensor (sub) Check [P.54A-99](#).

FUEL PUMP MODULE REPLACEMENT

M1135004901748

1. Remove the rear seat cushion assembly. (Refer to GROUP 52A, Rear Seat Assembly [P.52A-27](#)).
2. Remove the floor inspection lid (LH).

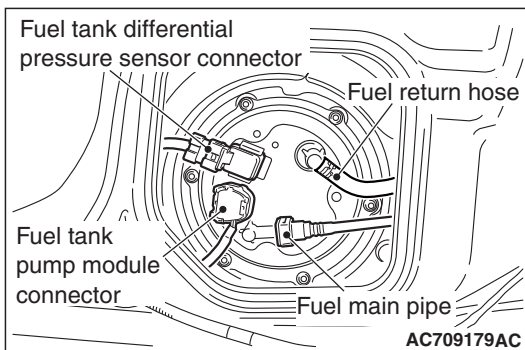
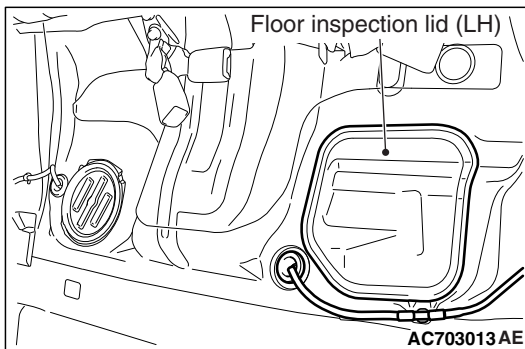

3. Disconnect the fuel pump module connector and fuel tank differential pressure sensor connector.
4. Release the fuel pressure in the fuel line. (Refer to GROUP 13A, On-vehicle Service –How to Reduce Pressurized Fuel Lines [P.13A-868](#)).
5. Disconnect the fuel return hose.

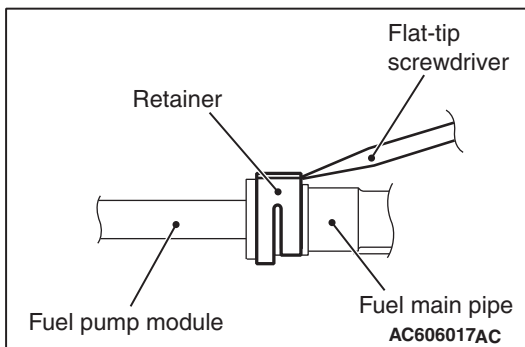

6. Insert a flat-tip screwdriver [6mm (0.24 inch) wide and 1mm (0.04 inch) thick] into the retainer of the fuel main pipe.

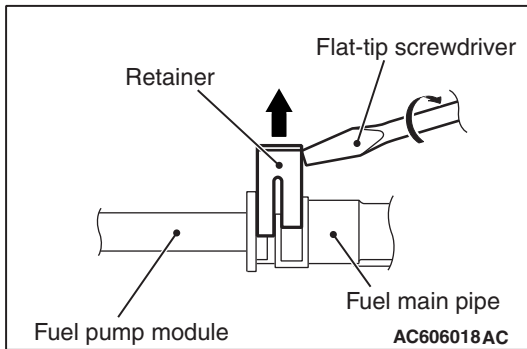

7. Turn the flat-tip screwdriver about 90 degrees angle to push up the retainer, and disconnect the fuel main pipe from the fuel pump module.

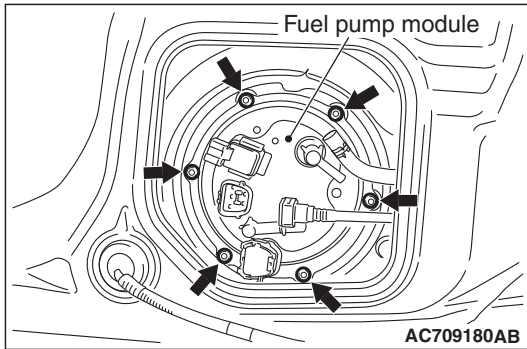

8. Remove the mounting nuts of fuel pump module.

⚠ CAUTION

When removing the fuel pump module from the service hole, be careful not to damage the gauge unit and the float of the fuel pump module.

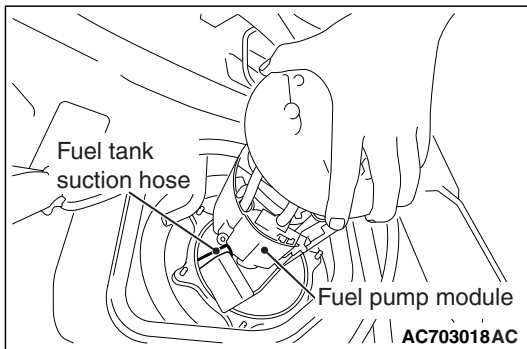

9. Disconnect the fuel tank suction hose while removing the fuel pump module from the service hole, and then remove the fuel pump module from the service hole.
10. Replace the fuel pump module gasket with a new one.

⚠ CAUTION

- When installing the fuel pump module into the fuel tank from the service hole, be careful not to damage the gauge unit and the float of the fuel pump module. In addition, be careful that the float does not catch the fuel tank suction hose in the fuel tank.
- When installing the fuel pump module into the fuel tank from the service hole, check that the moving part of the gauge works smoothly.

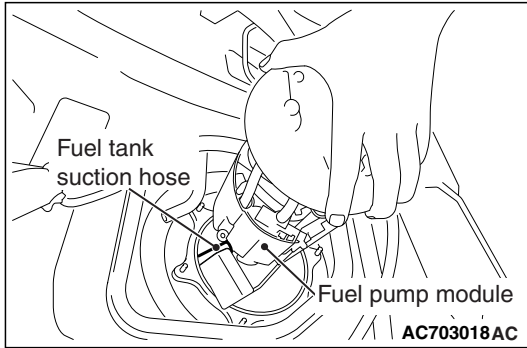

11. While inserting the fuel pump module into the fuel tank from the service hole, connect the fuel tank suction hose, and install the fuel pump module to the fuel tank.

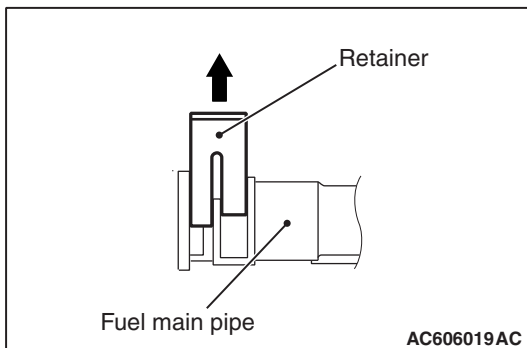

12. Before the installation, push up the retainer of the fuel main pipe.

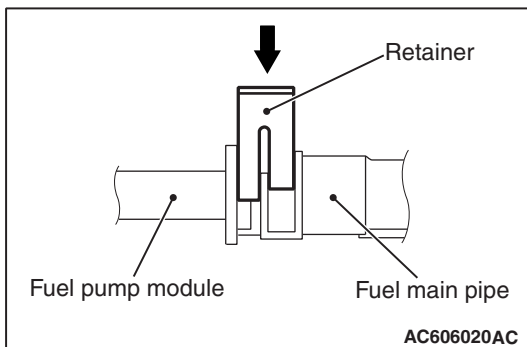

13. Connect the connector of fuel main pipe to the fuel pump module securely and push down the retainer of the connector to lock it firmly.

14. After the installation, slightly pull the fuel main pipe to check that it is connected securely. At this time, also check that there is approximately 1 mm (0.04 inch) play.

15. Connect the fuel return hose.

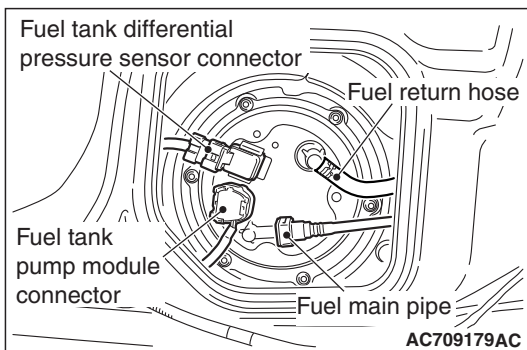

16. Connect the fuel pump module connector and fuel tank differential pressure sensor connector.

17. Install the floor inspection lid (LH).

18. Install the rear seat cushion assembly. (Refer to GROUP 52A, Rear Seat Assembly [P.52A-27](#)).

FUEL LEVEL SENSOR (SUB) REPLACEMENT

M1135005600082

1. Remove the rear seat cushion assembly. (Refer to GROUP 52A, Rear Seat Assembly P.52A-27).
2. Remove the floor inspection lid (RH).

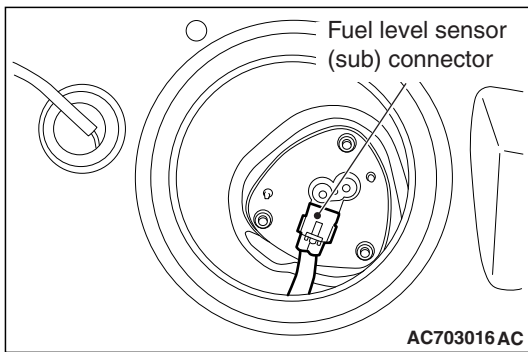
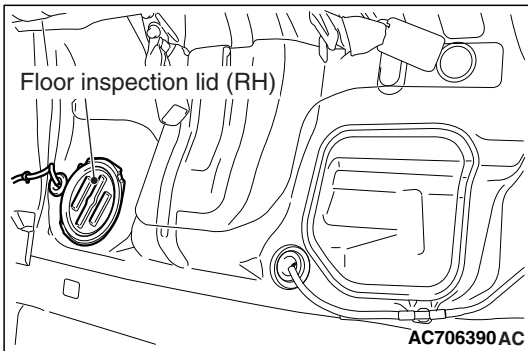

3. Disconnect the fuel level sensor (sub) connector.

CAUTION

Pay attention not to damage the fuel level sensor (sub) and the float of the fuel level sensor (sub) when withdrawing it from the service hole.

4. Remove the fuel level sensor (sub) mounting nuts, and remove the fuel level sensor (sub) from service hole.
5. Replace the fuel level sensor (sub) gasket with a new one.

CAUTION

Pay attention not to damage the fuel level sensor (sub) and the float of the fuel level sensor (sub) when installing it to the fuel tank through the service hole.

6. Install the fuel level sensor (sub) to the fuel tank through the service hole, and tighten the mounting nuts to the specified torque.

Tightening torque: 2.5 ± 0.4 N·m (22 ± 4 in-lb)

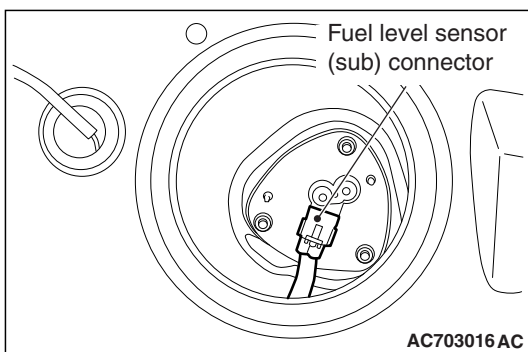
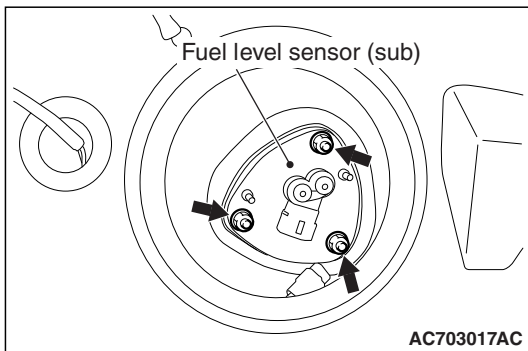

7. Connect the fuel level sensor (sub) connector.
8. Install the floor inspection lid (RH).
9. Install the rear seat cushion assembly. (Refer to GROUP 52A, Rear Seat Assembly P.52A-27).

FUEL TANK

REMOVAL AND INSTALLATION

M1135001903585

<FUEL TANK>

Pre-removal operation

- Fuel Pump Connector Disconnection (Refer to GROUP 13A, On-vehicle Service –How to Reduce Pressurized Fuel Lines P.13A-868).
- Fuel Draining.
- Propeller Shaft Removal (Refer to GROUP 25, Propeller Shaft P.25-7).
- Center Exhaust Pipe Removal (Refer to GROUP 15, Exhaust Pipe and Main Muffler P.15-26).
- Rear Seat Cushion Assembly Removal (Refer to GROUP 52A, Rear Seat Assembly P.52A-27).

Post-installation operation

- Rear Seat Cushion Assembly Installation (Refer to GROUP 52A, Rear Seat Assembly P.52A-27).
- Center Exhaust Pipe Installation (Refer to GROUP 15, Exhaust Pipe and Main Muffler P.15-26).
- Propeller Shaft Installation (Refer to GROUP 25, Propeller Shaft P.25-7).
- Fuel Refilling.
- Fuel Leak Check.

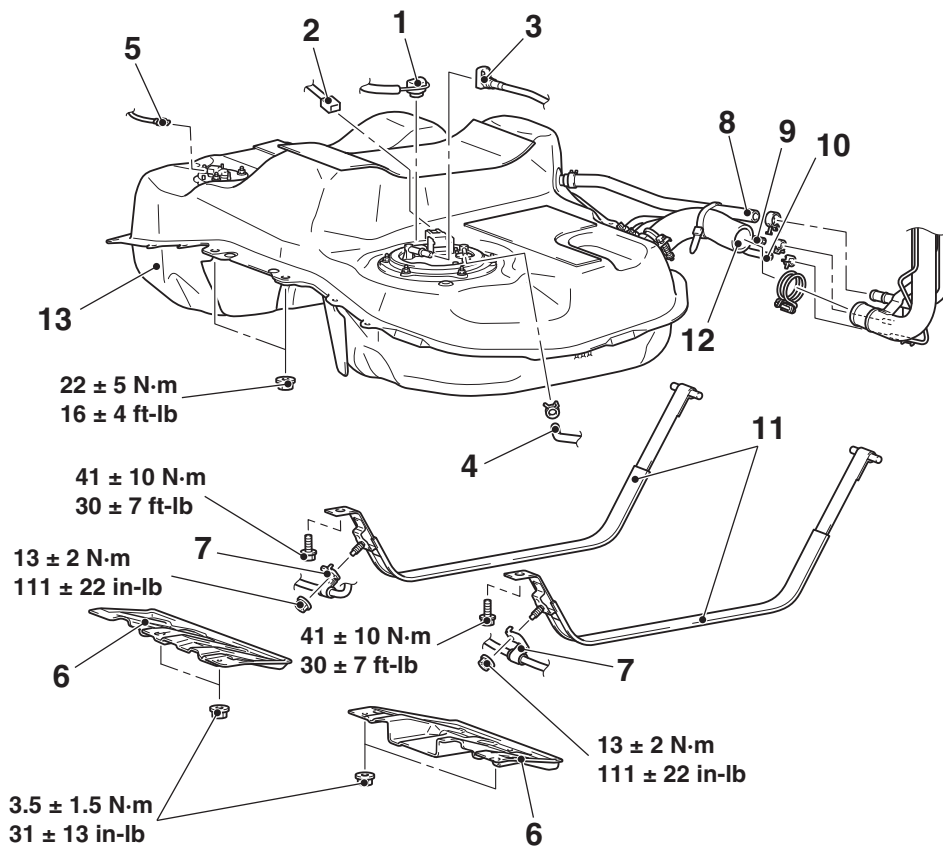

AC709094AB

Removal steps

- <<A>> 1. Fuel pump module connector connection
- <<A>> 2. Fuel tank differential pressure sensor connector connection
- <<A>> >>C<< 3. Fuel main pipe connection
- <<A>> 4. Fuel return pipe connection
- <> 5. Fuel level sensor (sub) connector connection
- 6. Front floor under cover

Removal steps (Continued)

- 7. Parking brake rear cable clamp connection
- 8. Fuel leveling hose connection
- 9. Fuel tank vapor hose connection
- 10. Fuel tank vapor hose connection
- 11. Fuel tank band
- 12. Fuel filler hose connection
- 13. Fuel tank assembly

<FUEL FILLER NECK>

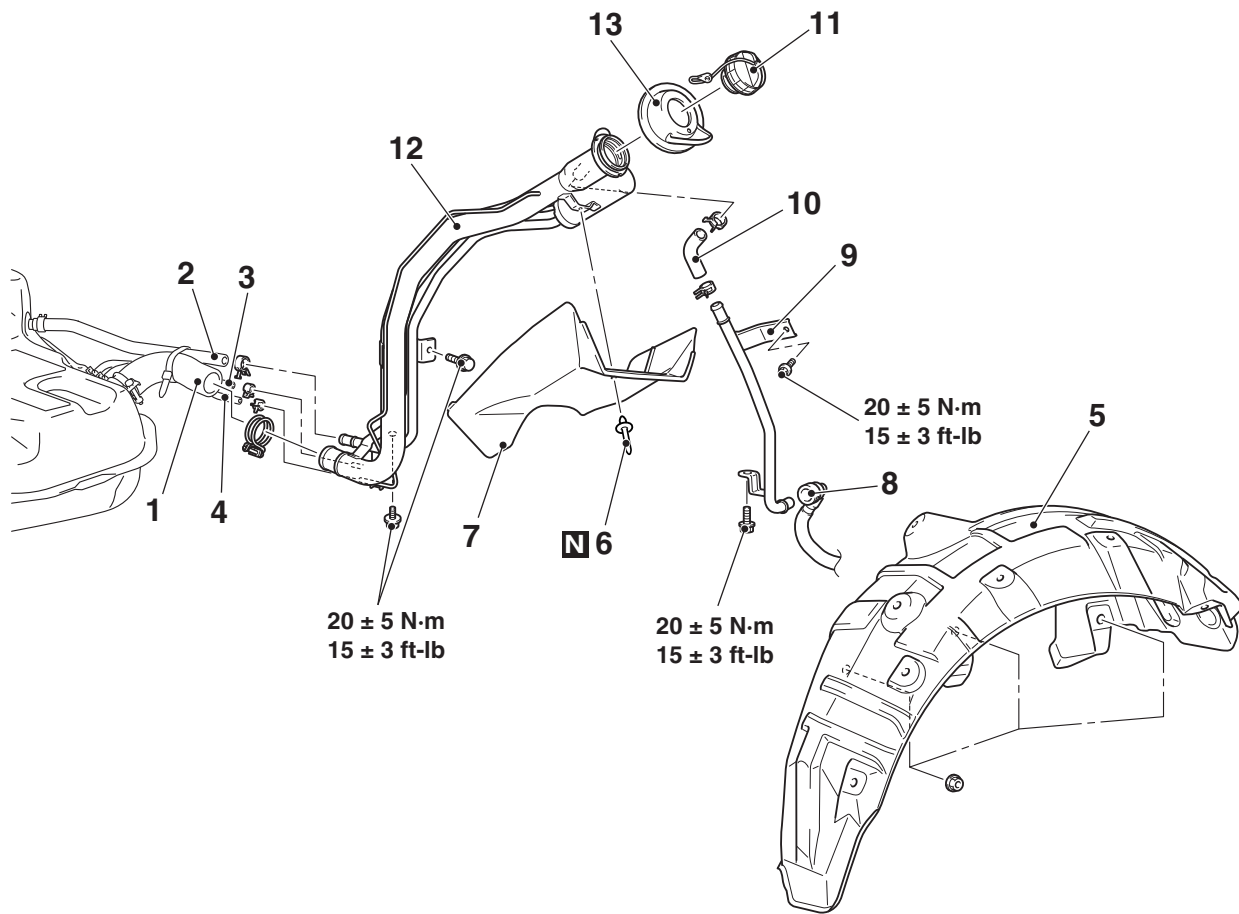

AC901649AB

Removal steps

- >>B<<
1. Fuel filler hose connection
 2. Fuel leveling hose connection
 3. Fuel vapor hose connection
 4. Fuel vapor hose connection
 5. Rear wheel splash shield front
<MR>
- <<D>> >>A<<
6. Rivet

Removal steps (Continued)

7. Fuel filler hose protector
8. Fuel vapor tube connection
9. Fuel leveling pipe
10. Fuel filler neck breather hose
11. Fuel cap
12. Fuel filler neck assembly
13. Filler neck boots

REMOVAL SERVICE POINTS

<<A>> FUEL PUMP MODULE CONNECTOR/FUEL TANK DIFFERENTIAL PRESSURE SENSOR CONNECTOR/FUEL MAIN PIPE/FUEL RETURN PIPE DISCONNECTION

1. Remove the floor inspection lid (LH).

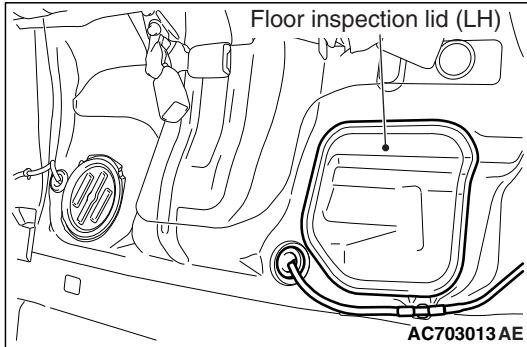

2. Disconnect the fuel pump module connector and fuel tank differential pressure sensor connector.

3. Disconnect the fuel return hose.

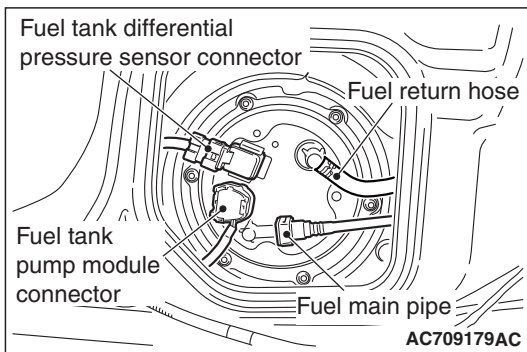

4. Insert a flat-tip screwdriver [6mm (0.24 inch) wide and 1mm (0.04 inch) thick] into the retainer of the fuel main pipe.

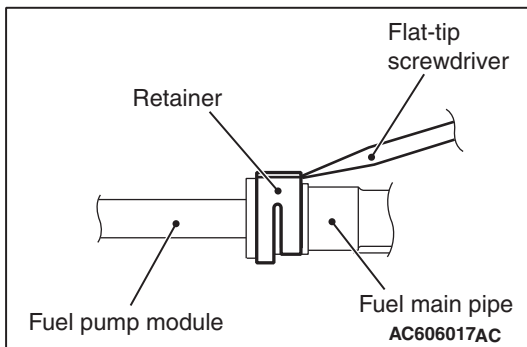

5. Turn the flat-tip screwdriver about 90 degrees angle to push up the retainer, and disconnect the fuel main pipe from the fuel pump module.

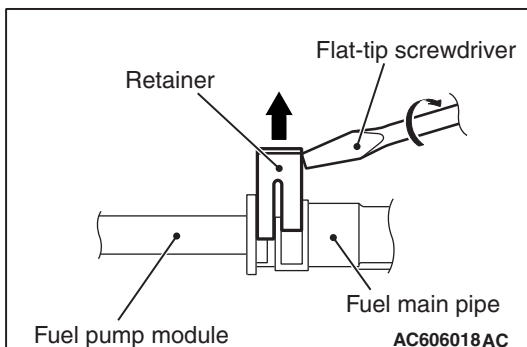

<> FUEL LEVEL SENSOR (SUB) REMOVAL

1. Remove the floor inspection lid (RH).

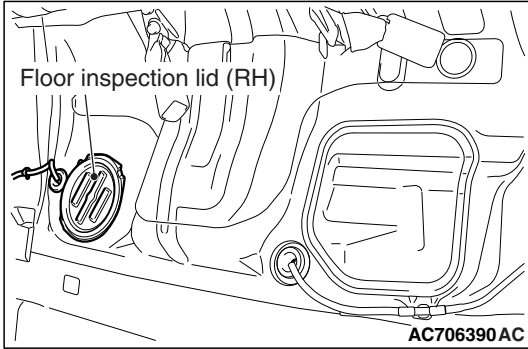

2. Disconnect the fuel level sensor (sub) connector.

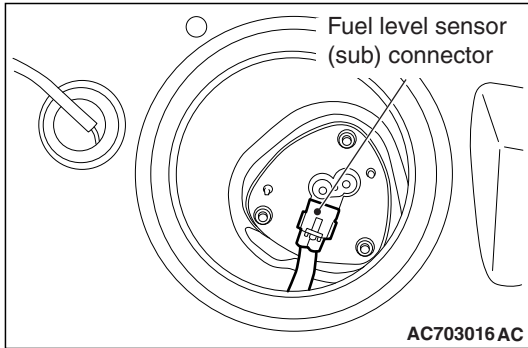

<<C>> FUEL TANK BAND/FUEL FILLER HOSE DISCONNECTION/FUEL TANK ASSEMBLY REMOVAL

1. Support the fuel tank assembly with a transmission jack to remove the connecting bolts of fuel tank band and the connecting nuts of fuel tank assembly.
2. Lower the transmission jack slightly and disconnect the fuel filler hose.
3. Tilt the fuel tank assembly, and remove the fuel tank assembly while avoiding the rear differential carrier.

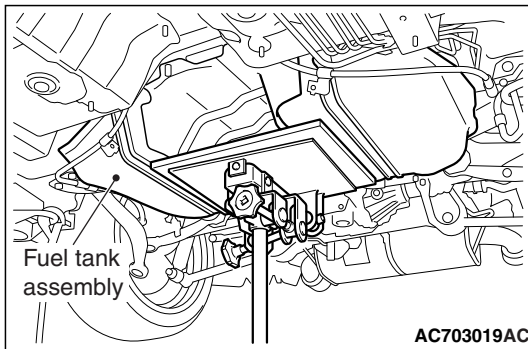

<<D>> RIVET REMOVAL

⚠ CAUTION

Be careful not to damage the fuel filler hose protector with the drill.

Use a 6.0 / diameter / mm drill to make a hole in the rivet to break it, and then remove the rivet.

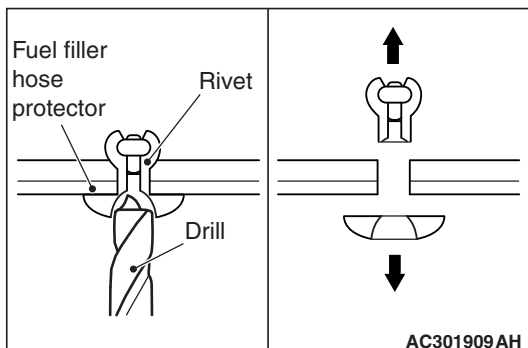

INSTALLATION SERVICE POINTS**>>A<< RIVET INSTALLATION**

Use a rivet tool shown in the illustration to connect the parts with rivets by the following procedures.

1. Insert the rivet into a corresponding location.
2. Set the rivet tool at a portion A of rivet.
3. While pushing the flange surface of the rivet onto parts to be fixed with the rivet tool, press the handle of the tool.
4. Thin part of portion A of the rivet will be cut off and the part is fixed in position.

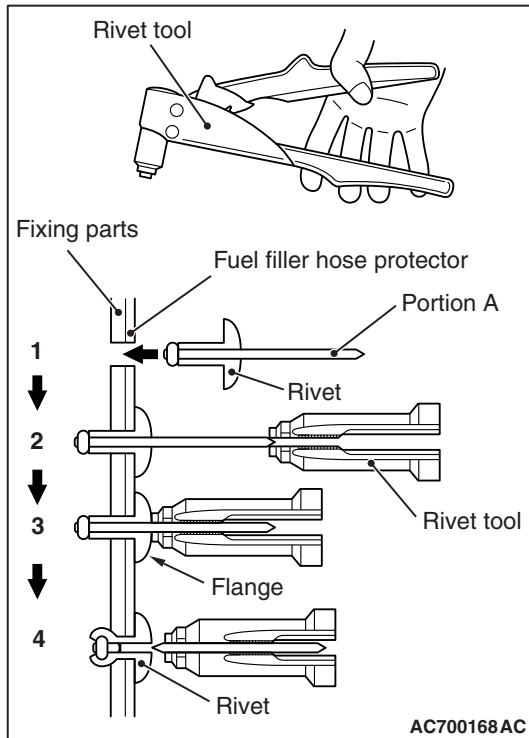
**>>B<< FUEL FILLER HOSE CONNECTION**

Connect the fuel filler hose, and tighten the bolt of hose clamp so that the bolt tightening dimension of the hose clamp becomes 8.5 ± 1.5 mm (0.33 ± 0.06 inch).

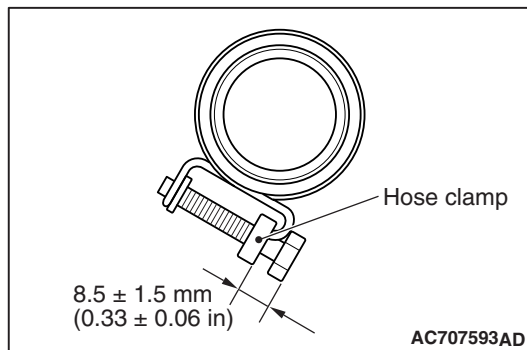
**>>C<< FUEL MAIN PIPE CONNECTION**

1. Before the installation, push up the retainer of the fuel main pipe.

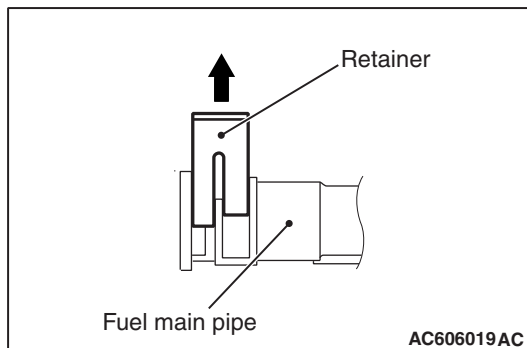

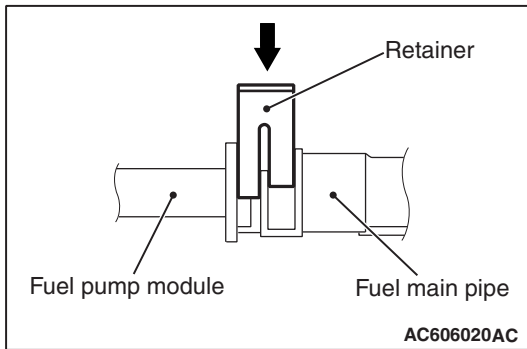

2. Connect the connector of fuel main pipe to the fuel pump module securely and push down the retainer of the connector to lock it firmly.
3. After the installation, slightly pull the fuel main pipe to check that it is connected securely. At this time, also check that there is approximately 1 mm (0.04 inch) play.

DISASSEMBLY AND ASSEMBLY
<FUEL TANK ASSEMBLY>

M1135006800368

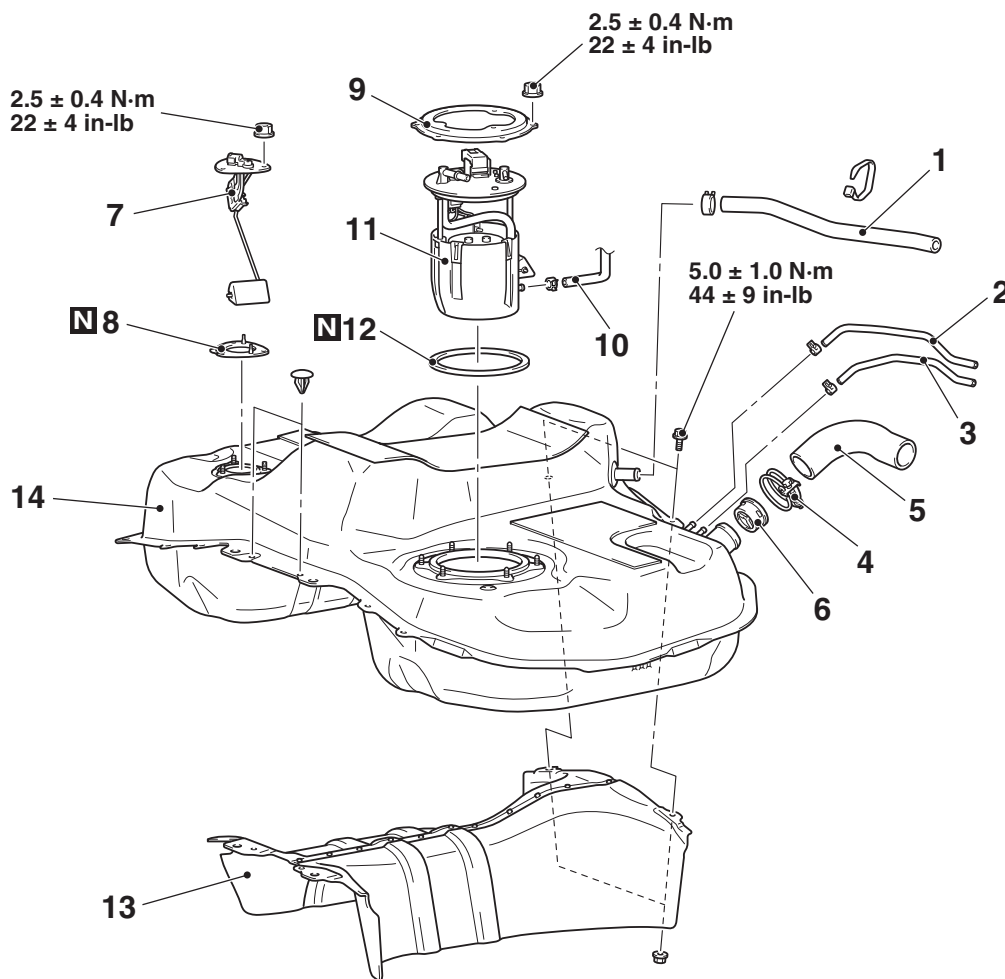

AC709132AB

Disassembly steps

1. Fuel leveling hose
2. Fuel tank vapor hose
3. Fuel tank vapor hose
- >>C<< 4. Hose clamp
5. Fuel filler hose
- <<A>> >>B<< 6. Fuel shut-off valve
7. Fuel level sensor (sub)
8. Fuel level sensor (sub) gasket

Disassembly steps (Continued)

9. Plate
10. Fuel tank suction hose connection
- >>A<< 11. Fuel pump module
12. Fuel pump module gasket
13. Fuel tank lower protector
14. Fuel tank

ASSEMBLY SERVICE POINT**<<A>> FUEL LEVEL SENSOR (SUB)/FUEL PUMP MODULE REMOVAL****⚠ CAUTION**

When removing the fuel level sensor (sub) and fuel pump module from the fuel tank, be careful not to damage the gauge unit and float of the fuel level sensor (sub) and fuel pump module.

While removing the fuel pump module from the fuel tank, disconnect the fuel tank suction hose from the fuel pump module, and remove the fuel pump module from the fuel tank.

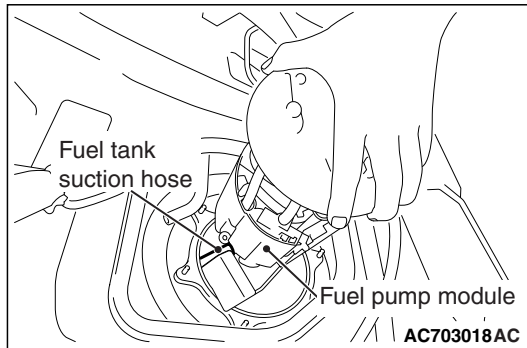
**DISASSEMBLY SERVICE POINTS****>>A<< FUEL PUMP MODULE INSTALLATION****⚠ CAUTION**

- When installing the fuel pump module into the fuel tank from the service hole, be careful not to damage the gauge unit and the float of the fuel pump module. In addition, be careful that the float does not catch the fuel tank suction hose in the fuel tank.
- When installing the fuel pump module into the fuel tank from the service hole, check that the moving part of the gauge works smoothly.

1. While inserting the fuel pump module into the fuel tank from the service hole, connect the fuel tank suction hose, and install the fuel pump module to the fuel tank.

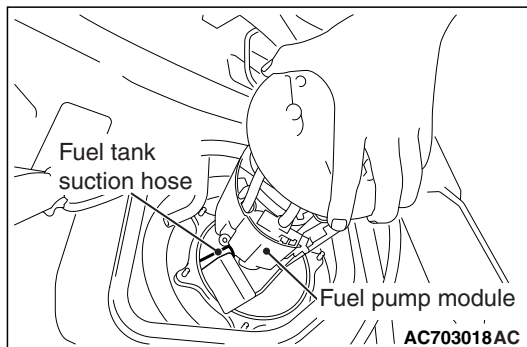
**>>B<< FUEL LEVEL SENSOR (SUB) INSTALLATION****⚠ CAUTION**

When installing the fuel level sensor (sub) into the fuel tank, be careful not to damage the gauge unit and float of the fuel level sensor (sub).

>>C<< HOSE CLAMP INSTALLATION

Connect the fuel filler hose, and tighten the bolt of hose clamp so that the bolt tightening dimension of the hose clamp becomes 8.5 ± 1.5 mm (0.33 ± 0.06 inch).

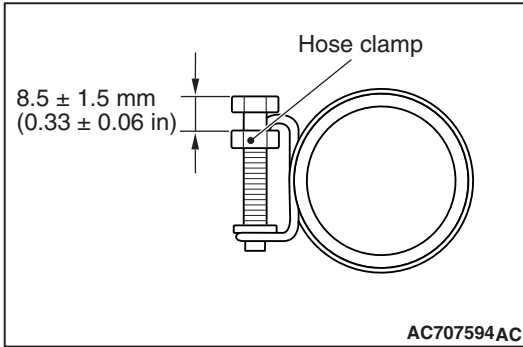

DISASSEMBLY AND REASSEMBLY

M1135004601651

FUEL PUMP MODULE

NOTE: For installation and removal, refer to Fuel Pump Module Replacement in On-vehicle Service (refer to P.13B-6).

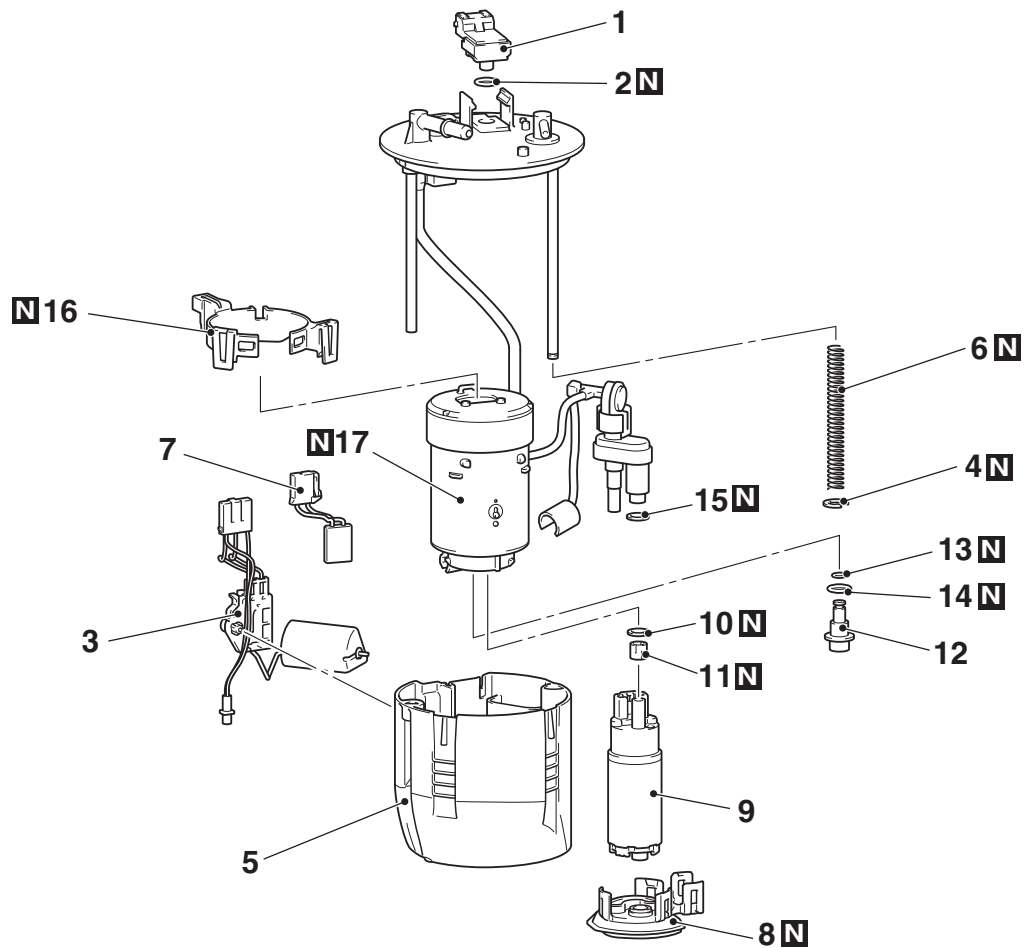

AC711219AD

Disassembly steps

1. Fuel tank differential pressure sensor
2. O-ring
3. Fuel gauge unit
4. Clip
5. Spring

>>A<<

Disassembly steps (Continued)

6. Fuel pump wiring harness
7. Fuel filter
8. Fuel pump assembly
9. O-ring
10. Spacer
11. Fuel filter cap sub assembly

>>A<<

Disassembly steps (Continued)

- >>A<< 12. O-ring
- >>A<< 13. O-ring
- >>A<< 14. O-ring
- 15. Fuel flange and filter assembly
- 16. Bracket
- 17. Subtank assembly

REASSEMBLY SERVICE POINT**>>A<< O-RING INSTALLATION**

To avoid twisting and damage, apply gasoline before installation of the O-ring.

FUEL TANK INSPECTION

M1135002000423

FUEL SHUT-OFF VALVE CHECK

Check that the flapper of the fuel shut-off valve opens and closes as shown in the illustration.

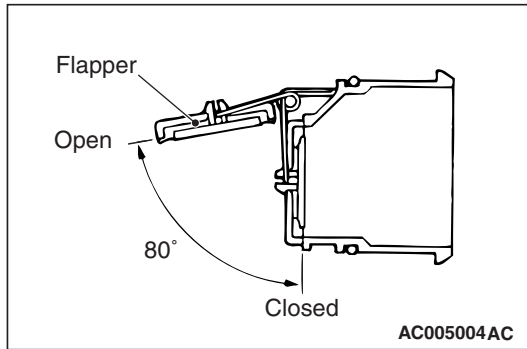
**FUEL TANK DIFFERENTIAL PRESSURE SENSOR CHECK****Required Special Tool:**

- MB991658: Test Harness Set
1. Disconnect the fuel tank differential pressure sensor connector and connect special tool MB991658 between the terminals of the disconnected connector.
 2. Turn the ignition switch to "ON" position and measure the voltage between terminal 1 and ground.

Standard value: 2.0 –3.0 V

