

GROUP 22B

MANUAL TRANSAXLE OVERHAUL

CONTENTS

GENERAL INFORMATION	22B-2	OUTPUT SHAFT	22B-29
GENERAL SPECIFICATIONS	22B-3	DISASSEMBLY AND ASSEMBLY	22B-29
SERVICE SPECIFICATIONS	22B-3	INSPECTION	22B-35
FASTENER TIGHTENING SPECIFICATIONS	22B-4	REVERSE IDLER GEAR	22B-37
SEALANTS AND ADHESIVES	22B-4	DISASSEMBLY AND ASSEMBLY	22B-37
LUBRICANTS	22B-5	INSPECTION	22B-39
ADJUSTMENT SNAP RING AND SPACERS	22B-6	CONTROL HOUSING	22B-40
SPECIAL TOOLS	22B-8	DISASSEMBLY AND ASSEMBLY	22B-40
TRANSAXLE	22B-12	SELECT LEVER	22B-43
DISASSEMBLY AND ASSEMBLY	22B-12	DISASSEMBLY AND ASSEMBLY	22B-43
INSPECTION	22B-19	CLUTCH HOUSING	22B-44
TRANSAXLE ADJUSTMENT	22B-19	DISASSEMBLY AND ASSEMBLY	22B-44
INPUT SHAFT	22B-22	TRANSAXLE CASE	22B-48
DISASSEMBLY AND ASSEMBLY	22B-22	DISASSEMBLY AND ASSEMBLY	22B-48
INSPECTION	22B-27	CENTER DIFFERENTIAL	22B-52
		DISASSEMBLY AND ASSEMBLY	22B-52
		TRANSFER	22B-55
		DISASSEMBLY AND ASSEMBLY	22B-55

GENERAL INFORMATION

M1222000101082

TRANSAXLE MODEL

Transaxle model	Engine model	Vehicle model
W5M6A-1-A4ZA	4B11 DOHC MIVEC	CZ4A

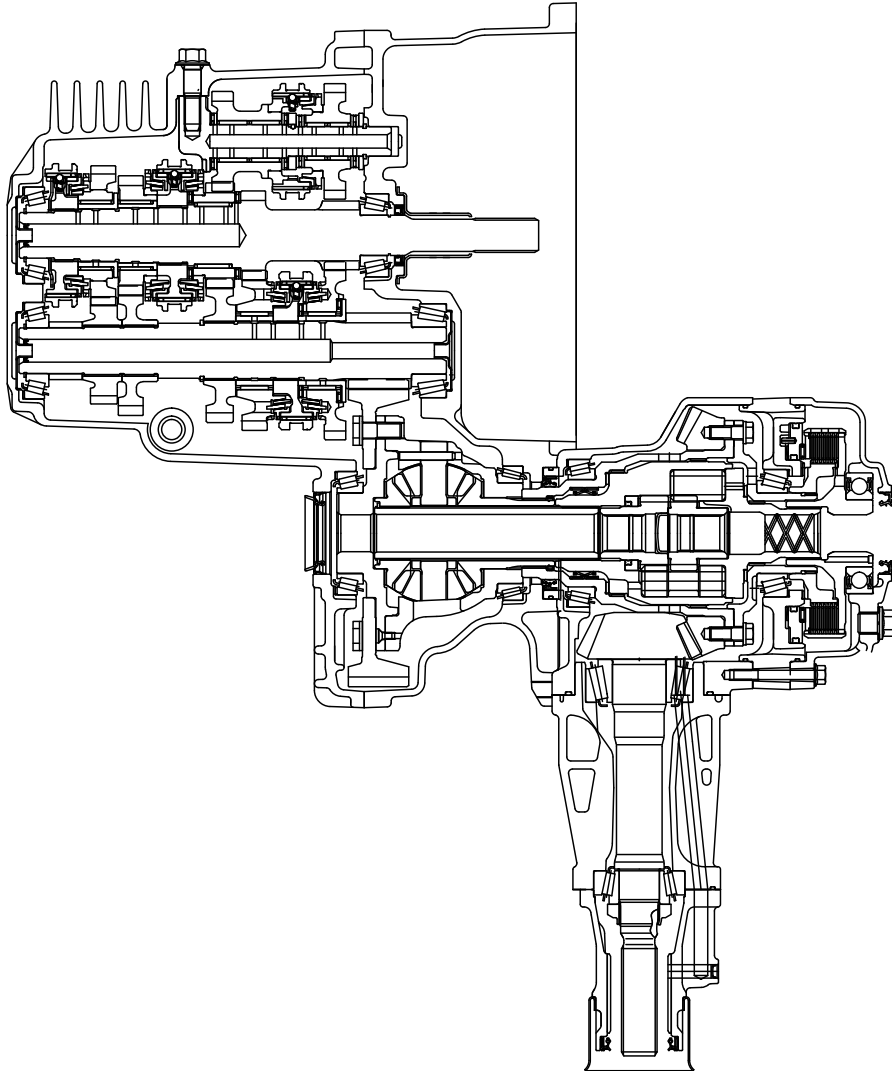
SECTIONAL VIEW

AK703412

GENERAL SPECIFICATIONS

M1222000201056

GEAR RATIO TABLE

Item		Specification
Transaxle model		W5M6A
Transaxle type		5-speed
Transaxle gear ratio	1st	2.857
	2nd	1.950
	3rd	1.444
	4th	1.096
	5th	0.761
	Reverse	2.892
	Final reduction ratio	4.687

SERVICE SPECIFICATIONS

M1222000300782

Item	Standard value	Limit
Transaxle		
Distance between the control shaft (in neutral) and shift cable bracket mm (in)	154 –156 (6.063 –6.141)	–
Distance between the select lever (3rd-4th speed position) and shift cable bracket mm (in)	139.2 –140.8 (5.481 –5.543)	–
Input shaft preload mm (in)	0.10 –0.17 (0.0039 –0.0067)	–
Output shaft preload mm (in)	0.15 –0.21 (0.0059 –0.0083)	–
Center differential preload mm (in)	0.06 –0.12 (0.0024 –0.0047)	–
Input shaft		
Input shaft taper roller bearing end play mm (in)	0.01 –0.09 (0.0004 –0.0035)	–
Synchronizer inner ring rear end to outer ring rear end clearance mm (in)	–	0.5 (0.02)
Output shaft		
Output shaft 3rd speed gear end play mm (in)	0.01 –0.09 (0.0004 –0.0035)	–
Output shaft taper roller bearing end play mm (in)	0.01 –0.09 (0.0004 –0.0035)	–
Synchronizer inner ring rear end to outer ring rear end clearance mm (in)	–	0.5 (0.02)
Reverse idler gear		
Reverse idler gear thrust washer end play mm (in)	0 –0.11 (0 –0.0043)	–
Synchronizer ring back surface to gear clearance mm (in)	–	0.5 (0.02)

FASTENER TIGHTENING SPECIFICATIONS

M1222013900427

TRANSAXLE

Item	Specification
Reverse shift lever	24 ± 4 N· m (17 ± 2 ft-lb)
Clutch housing-transaxle case mounting bolt	50 ± 5 N· m (37 ± 3 ft-lb)
Reverse idler gear shaft mounting bolt	78 ± 7 N· m (57 ± 4 ft-lb)
Poppet spring	32 ± 2 N· m (24 ± 1 ft-lb)
Control housing mounting bolt	24 ± 4 N· m (17 ± 2 ft-lb)
Select lever	24 ± 4 N· m (17 ± 2 ft-lb)
Harness bracket	24 ± 4 N· m (17 ± 2 ft-lb)
Back-up light switch	32 ± 2 N· m (24 ± 1 ft-lb)
1st-2nd speed rail switch	32 ± 2 N· m (24 ± 1 ft-lb)
Hanger bracket	24 ± 4 N· m (17 ± 2 ft-lb)
Stud adapter	50 ± 5 N· m (37 ± 3 ft-lb)
Shift cable bracket	24 ± 4 N· m (17 ± 2 ft-lb)
Transaxle-transfer mounting bolt	69 ± 9 N· m (51 ± 6 ft-lb)
Stopper bracket mounting bolt	19 ± 3 N· m (14 ± 2 ft-lb)
Select lever-select lever bracket connecting nut	11 ± 2 N· m (97 ± 17 in-lb)
Clutch release bearing retainer mounting bolt	10 ± 2 N· m (88 ± 17 in-lb)
Oil guide B	10 ± 2 N· m (88 ± 17 in-lb)
Center differential drive gear mounting bolt	133 ± 4 N· m (98 ± 2 ft-lb)

TRANSFER

Item	Specification
Cover	9.0 ± 2.0 N· m (80 ± 17 in-lb)

SEALANTS AND ADHESIVES

M1222000501217

TRANSAXLE

Item	Specified sealant
Mating face for transaxle case and clutch housing	Mitsubishi Part No. MD997740 or equivalent
Mating face for transaxle case and control housing	
Steel ball	3M™STUD Locking No.4710 or equivalent
Center differential drive gear bolt	
Air breather bracket	Three bond 1501 or equivalent

TRANSFER

Item	Specified sealant
Cover	Mitsubishi Part No. MD997740 or equivalent

FORM-IN-PLACE GASKET (FIPG)

This transaxle has several areas where the form-in-place gasket (FIPG) is used for sealing. To ensure that the FIPG fully serves its purpose, it is necessary to observe some precautions when applying it. Bead size, continuity and location are of paramount importance.

Too thin a bead could cause leaks. Too thick a bead, on the other hand, could be squeezed out of location, causing blocking or narrowing of fluid passages. To prevent leaks or blocking of passages, therefore, it is absolutely necessary to apply the FIPG evenly without a break, while observing the correct bead size. FIPG hardens as it reacts with the moisture in the atmospheric air, and it is usually used for sealing metallic flange areas.

CAUTION

When re-applying liquid gasket (FIPG), be sure that:

1. Residues of FIPG are cleared from all the ins and outs of parts;
2. Use Mitsubishi genuine parts cleaner (MZ100387) or equivalent to well degrease the FIPG-applied surface.
3. FIPG is correctly applied in accordance with FIPG Application.

Disassembly

Parts sealed with a FIPG can be easily removed without need for the use of a special method. In some cases, however, the FIPG in joints may have to be broken by tapping parts with a mallet or similar tool.

Surface Preparation

Thoroughly remove all substances deposited on the FIPG application surface, using a gasket scraper. Make sure that the FIPG application surfaces is flat and smooth. Also make sure that the surface is free from oils, greases and foreign substances. Do not fail to remove old FIPG that may remain in the fastener fitting holes.

FIPG Application

Applied FIPG bead should be of the specified size and free of any break. FIPG can be wiped away unless it has completely hardened. Install the mating parts in position while the FIPG is still wet. Do not allow FIPG to spread beyond the sealing areas during installation. Avoid operating the transaxle or letting oils or water come in contact with the sealed area before a time sufficient for FIPG to harden (approximately one hour) has passed. FIPG application method may vary from location to location. Follow the instruction for each particular case described later in this manual.

LUBRICANTS

M1222000400819

TRANSAXLE

Item	Specified sealant
Transaxle oil	Mitsubishi Genuine DiaQueen NEW MULTI GEAR OIL API classification GL-3, SAE 75W-80
Control shaft oil seal lip gear oil	
Oil seal (transaxle case)	
Select lever shoe	Mitsubishi Part No. 0101011 or equivalent
Input shaft oil seal lip gear oil	Retinax A

TRANSFER

Item	Specified lubricant
Transfer oil	Hypoid gear oil API classification GL-5, SAE90
O-ring	Mitsubishi Genuine DiaQueen ATF SPlII
Oil seal	Retinax A

ADJUSTMENT SNAP RING AND SPACERS

M1222012000799

Snap ring (For adjustment of input shaft rear bearing end play)

Thickness mm (in)	Thickness mm (in)
1.23 (0.0484)	1.55 (0.0610)
1.27 (0.0500)	1.59 (0.0626)
1.31 (0.0516)	1.63 (0.0642)
1.35 (0.0531)	1.67 (0.0657)
1.39 (0.0547)	1.71 (0.0673)
1.43 (0.0563)	1.75 (0.0689)
1.47 (0.0579)	1.79 (0.0705)
1.51 (0.0594)	

Spacer (For adjustment of input shaft end play)

Thickness mm (in)	Thickness mm (in)
0.80 (0.0315)	1.16 (0.0457)
0.83 (0.0327)	1.19 (0.0469)
0.86 (0.0339)	1.22 (0.0480)
0.89 (0.0350)	1.25 (0.0492)
0.92 (0.0362)	1.28 (0.0504)
0.95 (0.0374)	1.31 (0.0516)
0.98 (0.0386)	1.34 (0.0528)
1.01 (0.0398)	1.37 (0.0539)
1.04 (0.0409)	1.40 (0.0551)
1.07 (0.0421)	1.43 (0.0563)
1.10 (0.0433)	1.46 (0.0575)
1.13 (0.0445)	1.49 (0.0587)

Snap ring (For adjustment of output shaft 3rd speed gear end play)

Thickness mm (in)	Thickness mm (in)
2.23 (0.0878)	2.47 (0.0972)
2.27 (0.0894)	2.51 (0.0988)
2.31 (0.0909)	2.55 (0.1004)
2.35 (0.0925)	2.59 (0.1020)
2.39 (0.0941)	2.63 (0.1035)
2.43 (0.0957)	2.67 (0.1051)

Snap ring (For adjustment of output shaft rear bearing end play)

Thickness mm (in)	Thickness mm (in)
1.31 (0.0561)	1.55 (0.0610)
1.35 (0.0531)	1.59 (0.0626)
1.39 (0.0547)	1.63 (0.0642)

Thickness mm (in)	Thickness mm (in)
1.43 (0.0563)	1.67 (0.0657)
1.47 (0.0579)	1.71 (0.0673)
1.51 (0.0594)	

Spacer (For adjustment of output shaft end play)

Thickness mm (in)	Thickness mm (in)
0.86 (0.0339)	1.19 (0.0469)
0.89 (0.0350)	1.22 (0.0480)
0.92 (0.0362)	1.25 (0.0492)
0.95 (0.0374)	1.28 (0.0504)
0.98 (0.0386)	1.31 (0.0516)
1.01 (0.0398)	1.34 (0.0528)
1.04 (0.0409)	1.37 (0.0539)
1.07 (0.0421)	1.40 (0.0551)
1.10 (0.0433)	1.43 (0.0563)
1.13 (0.0445)	1.46 (0.0575)
1.16 (0.0457)	1.49 (0.0587)

Snap ring (For adjustment of reverse idler gear thrust washer end play)

Thickness mm (in)	Thickness mm (in)
1.77 (0.0697)	2.12 (0.0835)
1.82 (0.0717)	2.17 (0.0854)
1.87 (0.0736)	2.22 (0.0874)
1.92 (0.0756)	2.27 (0.0894)
1.97 (0.0776)	2.32 (0.0913)
2.02 (0.0795)	2.37 (0.0933)
2.07 (0.0815)	2.42 (0.0953)

Spacer (For adjustment of center differential case end play)

Thickness mm (in)	Thickness mm (in)
1.07 (0.0421)	1.34 (0.0528)
1.10 (0.0433)	1.37 (0.0539)
1.13 (0.0445)	1.40 (0.0551)
1.16 (0.0457)	1.43 (0.0563)
1.19 (0.0469)	1.46 (0.0575)
1.22 (0.0480)	1.49 (0.0587)
1.25 (0.0492)	1.52 (0.0598)
1.28 (0.0504)	1.55 (0.0610)
1.31 (0.0516)	

SPECIAL TOOLS

M122200600921

TRANSAXLE

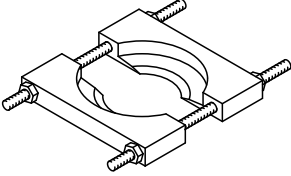
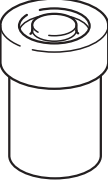
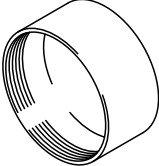
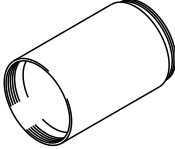
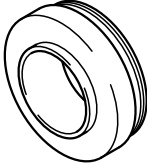
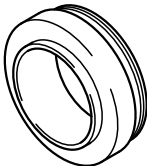
Tool	Tool number and name	Supersession	Application
	MD998917 Bearing remover	General service tool	Removal of gears and bearings
	MB990842 Drag link bushing remover and installer B	-	<ul style="list-style-type: none"> • Removal of input shaft 5th speed gear • Removal of output shaft taper roller bearing • Removal of output shaft 5th and 4th speed gears
	MD998812 Installer cap	General service tool	Use with installer and installer adapter
	MD998813 Installer-100	General service tool	Use with installer cap and installer adapter
	MD998819 Installer adapter (40)	General service tool	<ul style="list-style-type: none"> • Installation of taper roller bearing • Installation of output shaft 5th speed gear
	MD998822 Installer adapter (46)	-	<ul style="list-style-type: none"> • Installation of input shaft 3rd-4th speed synchronizer sleeve and 3rd-4th speed synchronizer hub • Installation of input shaft 5th speed synchronizer sleeve and 5th speed synchronizer hub • Installation of input shaft 4th speed gear sleeve • Installation of input shaft 5th speed gear sleeve • Installation of input shaft taper roller bearing • Installation of output shaft 3rd speed gear

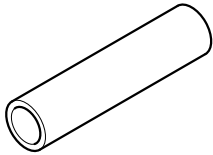
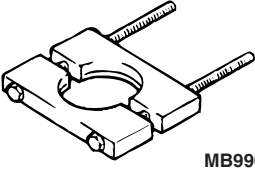
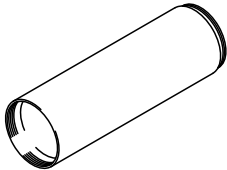
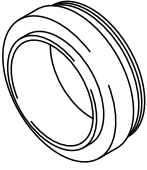
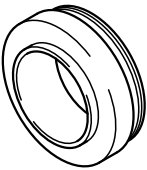
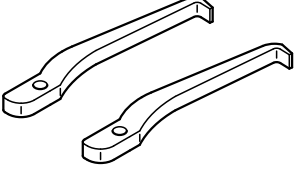
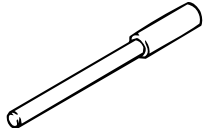
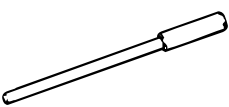
Tool	Tool number and name	Supersession	Application
	MD999601 Valve stem seal installer	–	Installation of input shaft and output shaft oil seal
 <p align="center">MB990560</p>	MB990560 Rear axle shaft bearing remover	–	Removal of output shaft taper roller bearing
	MD998814 Installer-200	MIT304180	Use with installer cap and installer adapter
	MD998824 Installer adapter (50)	General service tool	<ul style="list-style-type: none"> • Installation of output shaft 1st gear sleeve • Installation of output 1st-2nd speed synchronizer hub • Installation of output 2nd speed gear sleeve
	MD998821 Installer adapter (44)	MD998821	Installation of output shaft 4th speed gear
	MD999566 Claw	General service tool	Removal of control housing oil seal
 <p align="center">MB990947</p>	MB990947 Lower arm push arbor	MB990947-01 or general service tool	Removal of control housing slide ball bearing
	MB990984 Mount bushing remover and installer arbor	–	Installation of control housing slide ball bearing

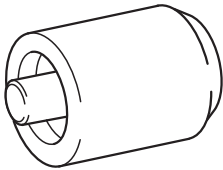
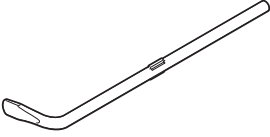
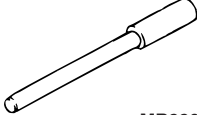
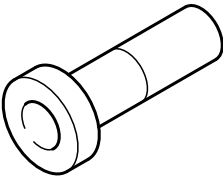
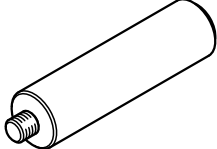
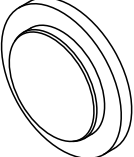
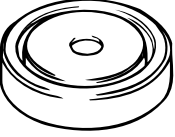
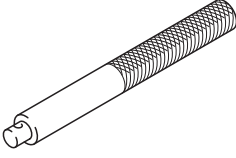
Tool	Tool number and name	Supersession	Application
	MB991246 Lower arm bushing arbor	–	Installation of control housing oil seal
	MB991946 Pry bar	–	Removal of oil guide
 MB990883	MB990883 Rear suspension bushing arbor	MB990883-01 or general service tool	<ul style="list-style-type: none"> • Removal of slide ball bearing • Installation of slide ball bearing
	MD999547 Oil seal installer	–	<ul style="list-style-type: none"> • Installation of oil guide • Installation of center differential taper roller bearing
	MB992075 Handle	–	Installation of oil seal
	MB992271 Oil seal installer	–	Installation of oil seal
	MB991115 Oil seal installer	MB991015-01	Installation of center differential oil seal
	MB990938 Installer bar	MB990938-01	Installation of center differential oil seal

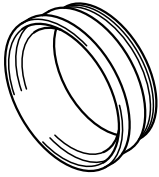
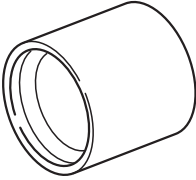
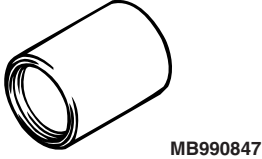
Tool	Tool number and name	Supersession	Application
	MD998830 Installer adapter (66)	–	Removal of center differential taper roller bearing
	MB992272 Bearing installer	–	Installation of center differential taper roller bearing
	MB990847 Rear suspension bushing remover and installer base	MB990847	Installation of center differential taper roller bearing

TRANSFER

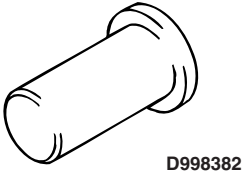
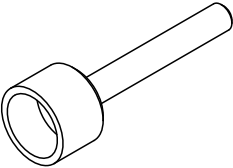
Tool	Tool number and name	Supersession	Application
	MD998382 Crankshaft front oil seal installer	MD998382-01	Installation of oil seal
	MD998550 Input shaft holder	–	Installation of oil seal

TRANSAXLE

DISASSEMBLY AND ASSEMBLY

M1222016500116

Apply gear oil to all moving parts before installation.

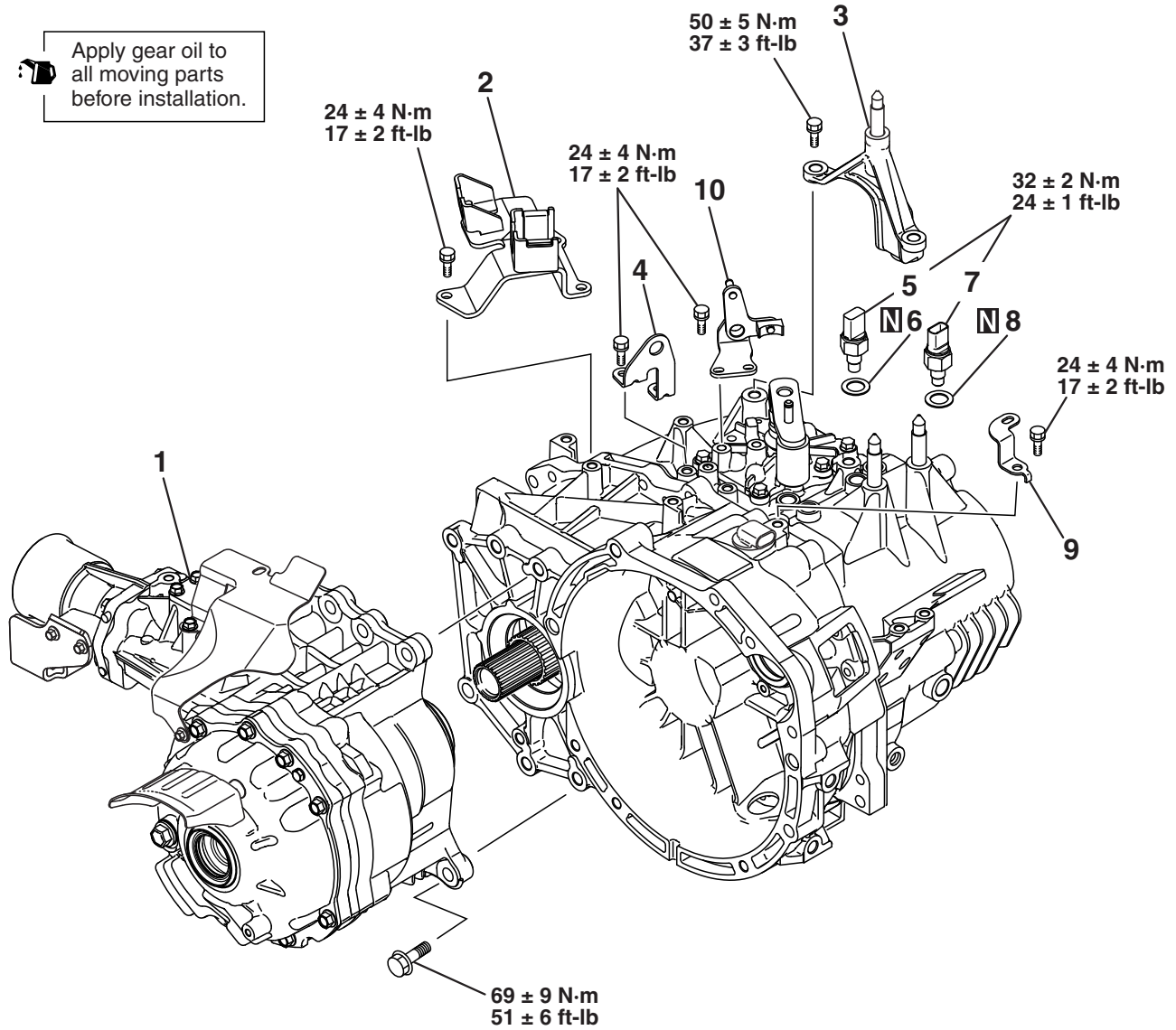

AK703151AC

Removal steps

- >>J<< 1. Transfer assembly
- >>J<< 2. Shift cable bracket
- >>J<< 3. Stud adapter
- >>J<< 4. Hanger bracket
- >>K<< 5. 1st-2nd speed rail switch

Removal steps (Continued)

- >>K<< 6. Gasket
- >>K<< 7. Back-up light switch
- >>K<< 8. Gasket
- >>K<< 9. Harness bracket
- >>K<< 10. Select lever

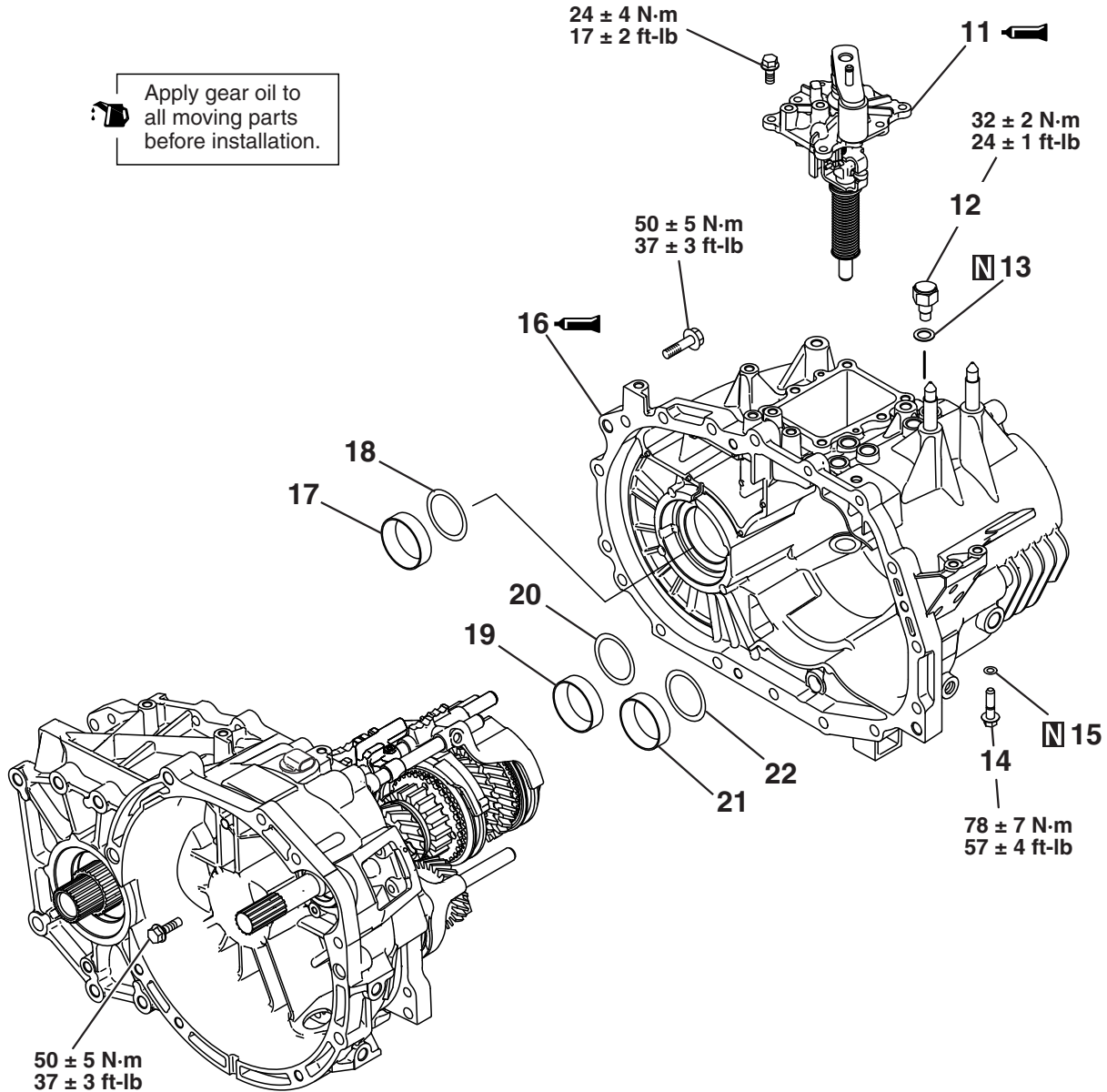

AK703162AC

Removal steps

- >>H<< 11. Control housing
12. Poppet spring
13. Gasket
14. Reverse idler gear shaft mounting bolt
15. Gasket
>>G<< 16. Transaxle case

Removal steps (Continued)

17. Outer race (for center differential)
18. Spacer (for center differential)
19. Outer race (for output shaft)
20. Spacer (for output shaft)
21. Outer race (for input shaft)
22. Spacer (for input shaft)

Installation steps (Continued)

- >>B<< 41. Spring pin
- >>C<< 31. Reverse idler gear assembly
30. 3rd-4th speed shift rail
- >>D<< 29. Spring pin
28. Steel ball
27. Steel ball
- >>E<< 26. 5th-reverse speed shift rail
25. Reverse shift fork
24. Reverse shift rail
- >>F<< 23. Reverse shift lever

DISASSEMBLY SERVICE POINTS

<<A>> STEEL BALL REMOVAL

Remove the steel balls at the illustrated positions from the shift lug and 5th speed shift fork.

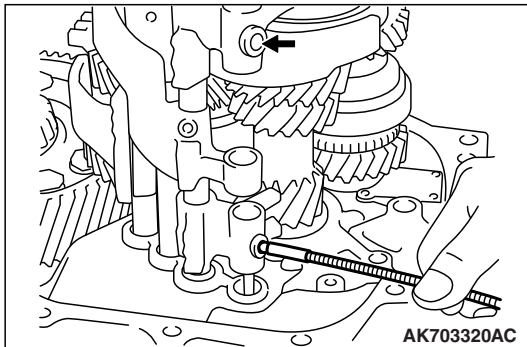

<> SPRING PIN REMOVAL

Knock the spring pin out of the 3rd-4th speed shift fork from the illustrated direction.

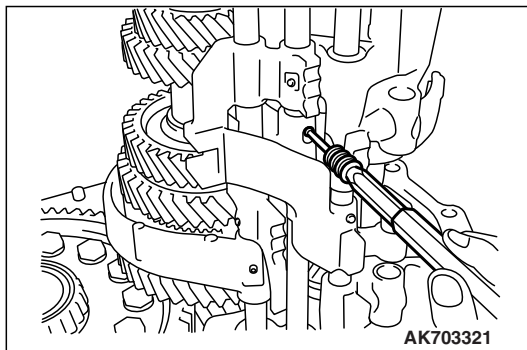

**<<C>> REVERSE IDLER GEAR ASSEMBLY
REMOVAL**

Pull up the input shaft and output shaft together, and remove the reverse idler gear assembly.

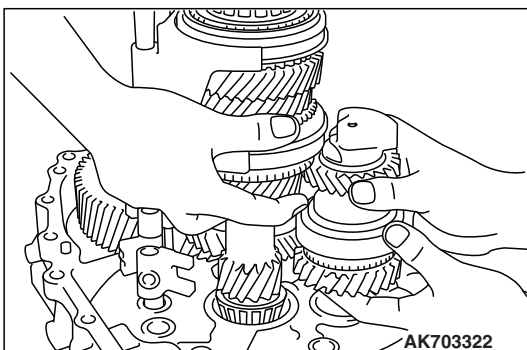

<<D>> 3RD-4TH SPEED SHIFT FORK / 5TH SPEED SHIFT FORK / SHIFT LUG / 5TH SPEED SHIFT RAIL ASSEMBLY / INPUT SHAFT ASSEMBLY / OUTPUT SHAFT ASSEMBLY / 1ST-2ND SPEED SHIFT FORK / 1ST-2ND SPEED SHIFT RAIL ASSEMBLY REMOVAL

With the differential assembly raised a little, remove the 3rd-4th speed shift fork, 5th speed shift fork, shift lug, 5th speed shift rail assembly, output shaft assembly, 1st-2nd speed shift fork, 1st-2nd speed shift rail assembly and input shaft assembly as a set.

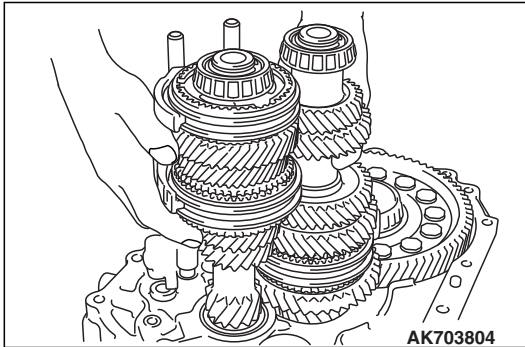

<<E>> SPRING PIN REMOVAL

Knock the spring pin out of the 1st-2nd speed shift fork from the illustrated direction.

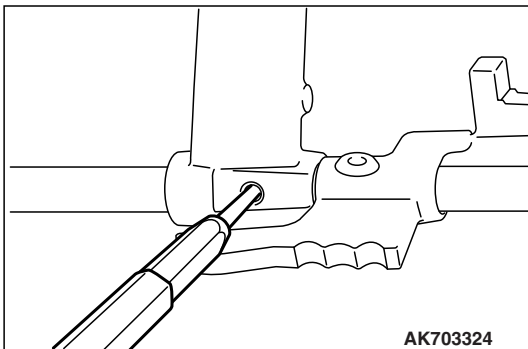

ASSEMBLY SERVICE POINTS

>>A<< 3RD-4TH SPEED SHIFT FORK / 5TH SPEED SHIFT FORK / SHIFT LUG / 5TH SPEED SHIFT RAIL ASSEMBLY / INPUT SHAFT ASSEMBLY / OUTPUT SHAFT ASSEMBLY REMOVAL

With the differential assembly raised a little, install the 3rd-4th speed shift fork, 5th speed shift fork, shift lug, 5th speed shift rail assembly, input shaft assembly and output shaft assembly as a set.

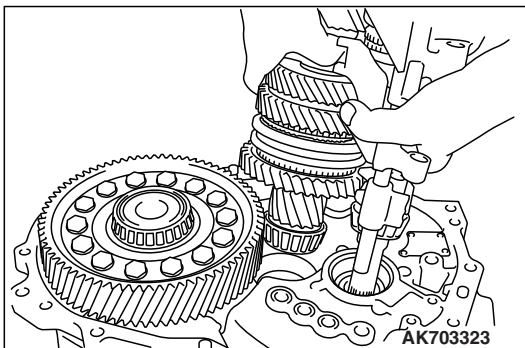

>>B<< SPRING PIN INSTALLATION

Install the spring pin to the shift rail so that the slit of the spring pin aligns with the center axis of the rail as shown.

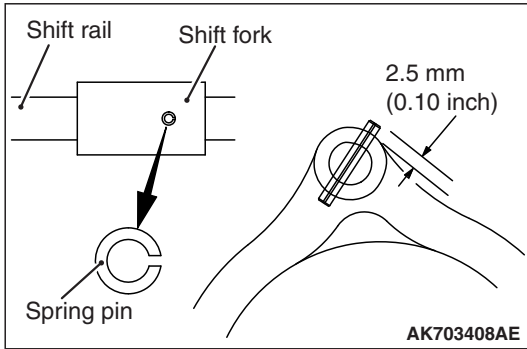

>>C<< REVERSE IDLER GEAR ASSEMBLY INSTALLATION

Install the reverse idler gear assembly so that the notch of the reverse idler gear shaft and 1st-2nd speed synchronizer sleeve meet at the illustrated position.

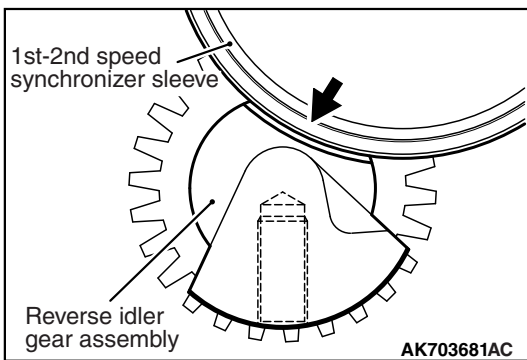

>>D<< SPRING PIN INSTALLATION

Install the spring pin to the shift rail so that the slit of the spring pin aligns with the center axis of the rail as shown.

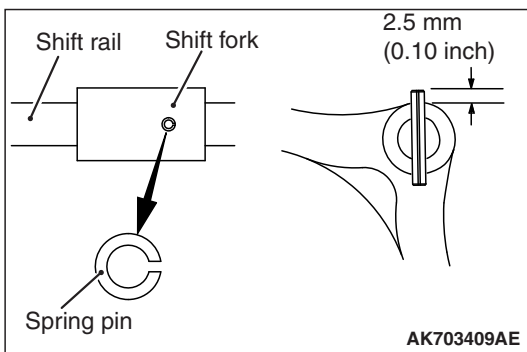

>>E<< 5TH-REVERSE SPEED SHIFT RAIL INSTALLATION

Install the 5th-reverse speed shift rail, with its identification groove to the clutch housing side.

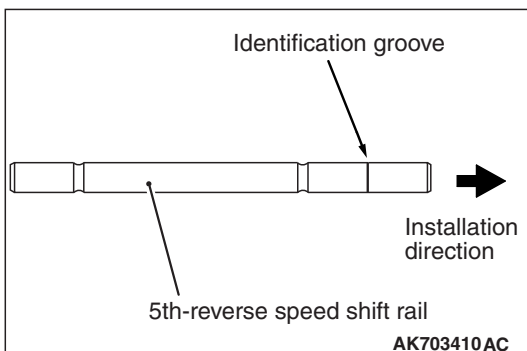

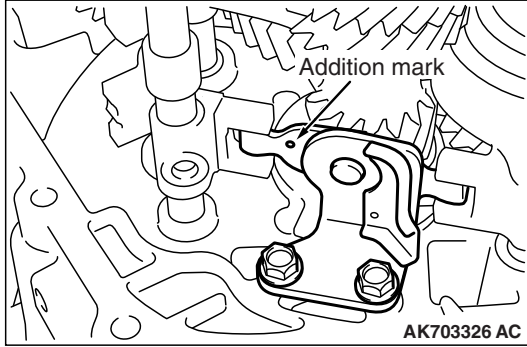
**>>F<< REVERSE SHIFT LEVER INSTALLATION**

Install the reverse shift lever so that its identification mark is located at the illustrated position.

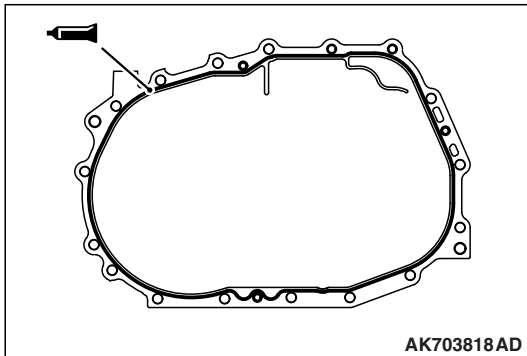
**>>G<< TRANSAXLE CASE INSTALLATION**

1. Completely degrease the FIPG-applied surface so that water and oil including the old sealant cannot adhere to the surface coated with the sealant.

Never touch the degreased surface by hand.

2. Apply a bead (approximately 2.5 mm (0.10 inch) thick) of specified sealant to the transaxle case as shown.

Specified sealant: Mitsubishi Part No. MD997740 or equivalent

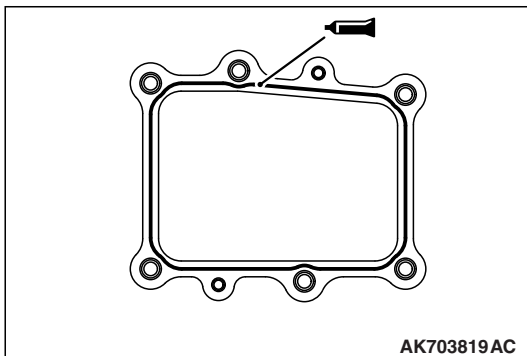
**>>H<< CONTROL HOUSING INSTALLATION**

1. Completely degrease the FIPG-applied surface so that water and oil including the old sealant cannot adhere to the surface coated with the sealant.

Never touch the degreased surface by hand.

2. Apply a bead (approximately 3.5 mm (0.14 inch) thick) of specified sealant to the control housing as shown.

Specified sealant: Mitsubishi Part No. MD997740 or equivalent

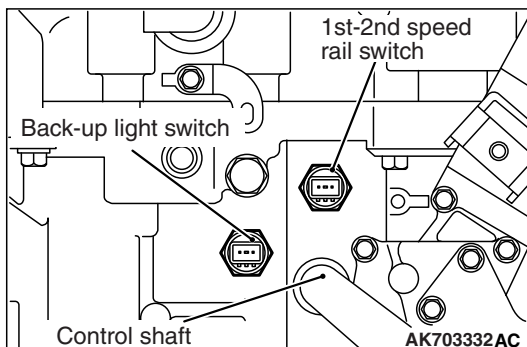
**>>I<< BACK-UP LIGHT SWITCH / 1ST-2ND SPEED RAIL SWITCH INSTALLATION**

Install the back-up light switch and 1st-2nd speed rail switch at the illustrated positions.

>>J<< SHIFT CABLE BRACKET INSTALLATION

1. Install the shift cable bracket loosely.
2. Put the control shaft into neutral.
3. Position the shift cable bracket so that the distance between the control shaft and shift cable bracket is within the standard value. Then fix the bracket securely.

Standard value: 154 –156 mm (6.063 –6.141 inch)

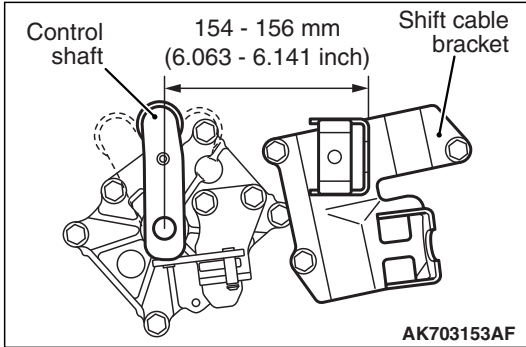

4. Install the select lever bracket loosely.
5. Put the select lever into the 3rd-4th speed position.
6. Position the select lever bracket so that the distance between the select lever and shift cable bracket is within the standard value. Then fix the bracket securely.

Standard value: 139.2 –140.8 mm (5.481 –5.543 inch)

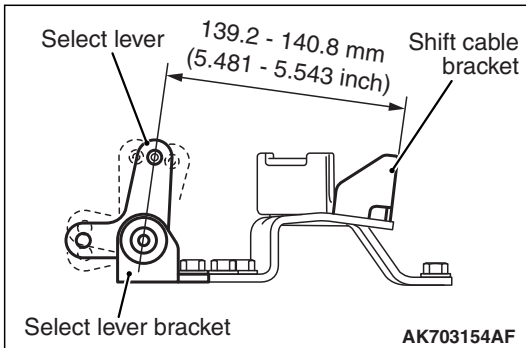

INSPECTION

M1222016600049

BACKUP LIGHT SWITCH / 1-2 speed rall switch

Check for continuity between terminals.

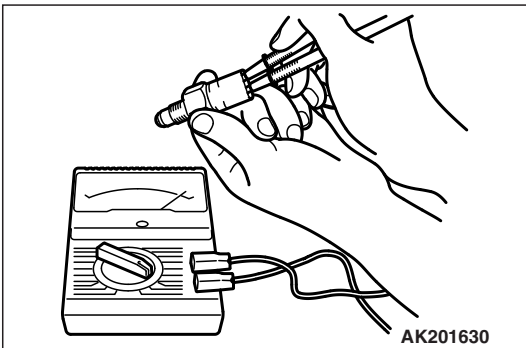

Switch Condition	Continuity
Pressed	Open
Released	Conductive

TRANSAXLE ADJUSTMENT

M1222013800129

ADJUSTMENT BEFORE ASSEMBLY

SPACER SELECTION FOR INPUT SHAFT PRE-LOAD / OUTPUT SHAFT PRELOAD / CENTER DIFFERENTIAL PRELOAD ADJUSTMENT

<Measurement using solder>

- If soft solder is not available, select the spacer in accordance with Plastigage method.
- If the spacer appropriate for the standard value cannot be selected using soft solder, select the spacer in accordance with Plastigage method.

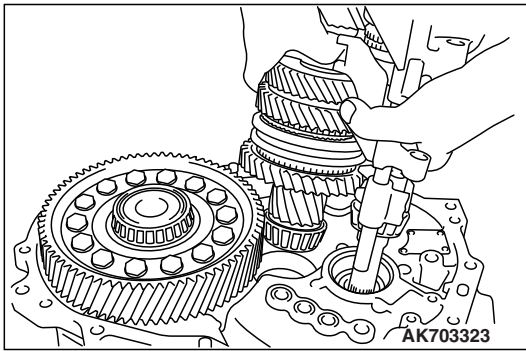

1. Install the input shaft, output shaft and center differential as a set to the clutch housing.

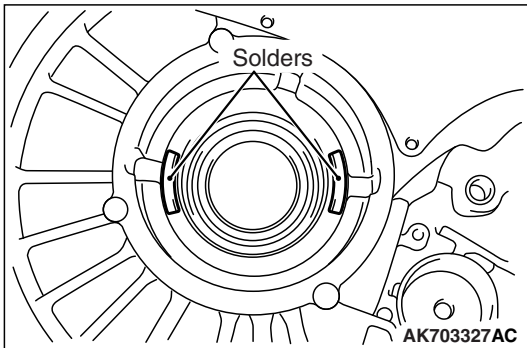

2. Put a piece of solder [1.6 mm (0.06 in) diameter, 10 mm (0.39 in) long] on the transaxle case at the positions shown in the illustration.
3. Install the bearing outer races on the pieces of solder.
4. Install the clutch housing to the transaxle case and tighten the bolts to the specified torque.
5. Remove the clutch housing, then remove the bearing outer races and take out crushed pieces of solder.

NOTE: If the pieces of solder have not crushed, use thicker solders and repeat steps 2 to 3.

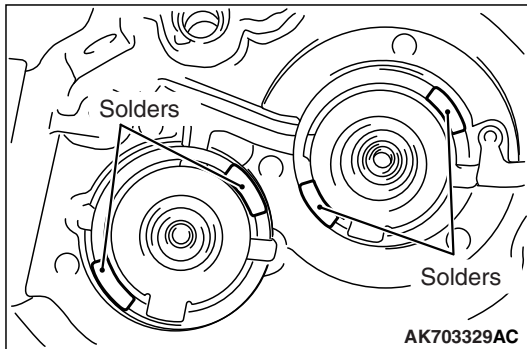

6. Measure the thickness of crushed solder with a micrometer, select the spacers that provide the standard preload values and install them.

- Input shaft

Input shaft preload

Spacer thickness: $[T + 0.10 \text{ mm (0.0039 inch)}] - [T + 0.17 \text{ mm (0.0067 inch)}]$

T: Thickness of crushed solder mm (inch)

Standard value: 0.10 – 0.17 mm (0.0039 – 0.0067 inch)

- Output shaft

Output shaft preload

Spacer thickness: $[T + 0.15 \text{ mm (0.0059 inch)}] - [T + 0.21 \text{ mm (0.0083 inch)}]$

T: Thickness of crushed solder mm (inch)

Standard value: 0.15 – 0.21 mm (0.0059 – 0.0083 inch)

- Center differential

Center differential preload

Spacer thickness: $[T + 0.06 \text{ (0.0024 inch)}] - [T + 0.12 \text{ mm (0.0047 inch)}]$

T: Thickness of crushed solder mm (inch)

Standard value: 0.06 – 0.12 mm (0.0024 – 0.0047 inch)

<Measurement using plastigage>

1. Install the input shaft, output shaft and center differential as a set to the clutch housing.

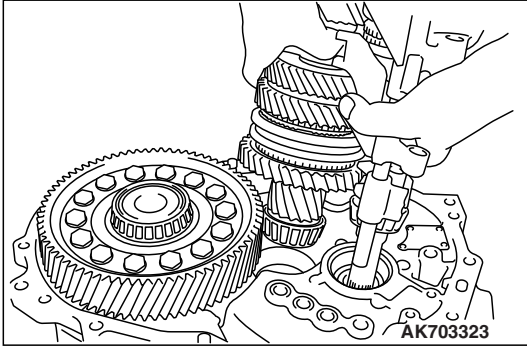

2. Install the thinnest spacers in position for measurement.
3. Put a piece of Plastigage [about 10 mm (0.39 in) long] on the transaxle case at the positions shown in the illustration.
4. Install the bearing outer races.
5. Install the clutch housing to the transaxle case and tighten the bolts to the specified torque.
6. Remove the clutch housing, then remove the bearing outer races and take out crushed pieces of Plastigage.
7. If the pieces of Plastigage have not crushed and clearance measurement is impossible, replace them with thicker ones and repeat steps 3 to 5.
8. Using the scale printed on the Plastigage package, measure the width of crushed pieces of Plastigage at their widest part, select the spacers that provide the standard preload values and install them.

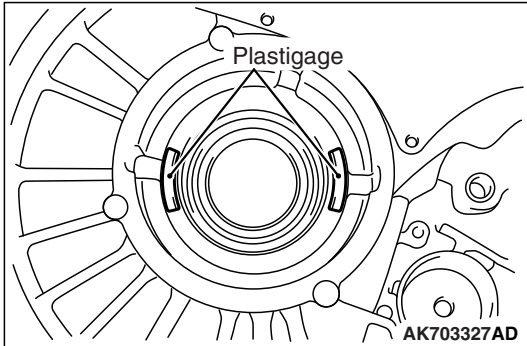

- Input shaft

Input shaft preload

Spacer thickness: $[T1 + T2 + 0.10 \text{ mm (0.0039 inch)}] -$

$[T1 + T2 + 0.17 \text{ mm (0.0067 inch)}]$

T1: Thickness of crushed Plastigage mm (inch)

T2: Thickness of spacer used for measurement mm (inch)

Standard value: 0.10 –0.17 mm (0.0039 –0.0067 inch)

- Output shaft

Output shaft preload

Spacer thickness: $[T1 + T2 + 0.15 \text{ mm (0.0059 inch)}] -$

$[T1 + T2 + 0.21 \text{ mm (0.0083 inch)}]$

T1: Thickness of crushed Plastigage mm (inch)

T2: Thickness of spacer used for measurement mm (inch)

Standard value: 0.15 –0.21 mm (0.0059 –0.0083 inch)

- Center differential

Center differential preload

Spacer thickness: $[T1 + T2 + 0.06 \text{ mm (0.0024 inch)}] -$

$[T1 + T2 + 0.12 \text{ mm (0.0047 inch)}]$

T1: Thickness of crushed Plastigage mm (inch)

T2: Thickness of spacer used for measurement mm (inch)

Standard value: 0.06 –0.12 mm (0.0024 –0.0047 inch)

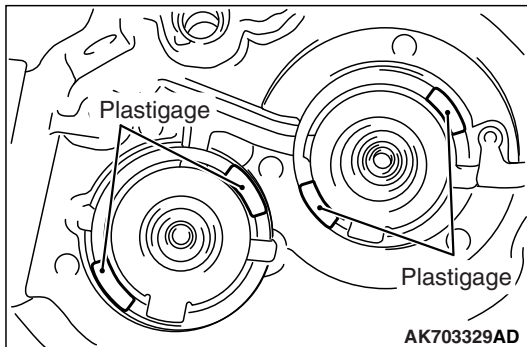

INPUT SHAFT

DISASSEMBLY AND ASSEMBLY

M1222001600764

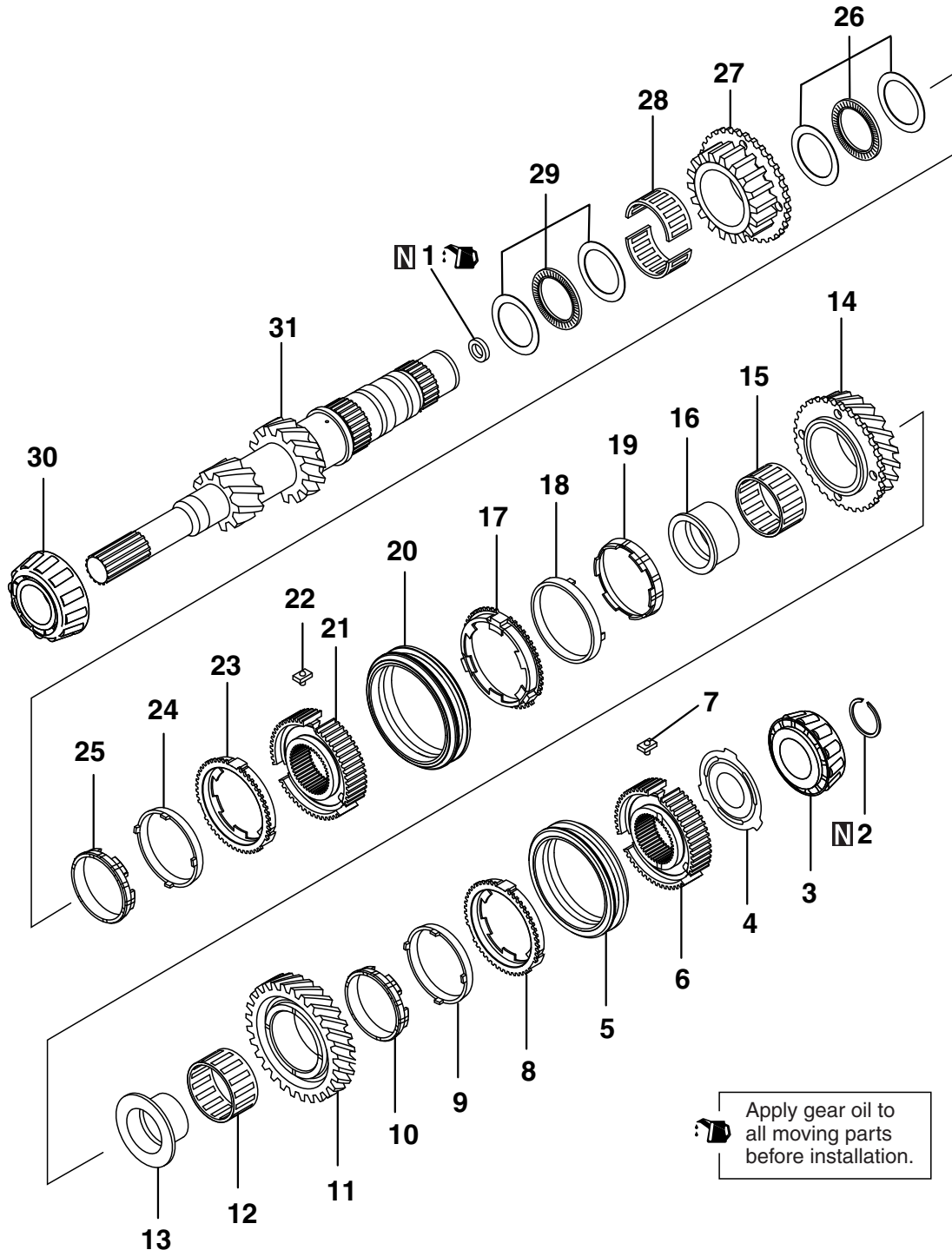

- Removal steps**
- >>|<< 1. Oil seal
 - >>H<< 2. Snap ring
 - <<A>> >>G<< 3. Taper roller bearing
 - <<A>> 4. Synchronizer key stopper plate
 - <<A>> >>F<< 5. 5th speed synchronizer sleeve
 - <<A>> >>F<< 6. 5th speed synchronizer hub
 - <<A>> 7. Synchronizer key

- Removal steps (Continued)**
- <<A>> 8. Synchronizer outer ring
 - <<A>> 9. Synchronizer cone
 - <<A>> 10. Synchronizer inner ring
 - <<A>> 11. 5th speed gear
 - <<A>> 12. Needle roller bearing
 - <<A>> 13. 5th speed gear sleeve
 - <<A>> 14. 4th speed gear

Removal steps (Continued)

- | | |
|-------------|---------------------------------------|
| <> | 15. Needle roller bearing |
| <> >>D<< | 16. 4th speed gear sleeve |
| <> | 17. Synchronizer outer ring |
| <> | 18. Synchronizer cone |
| <> | 19. Synchronizer inner ring |
| <> >>C<< | 20. 3rd-4th speed synchronizer sleeve |
| <> >>C<< | 21. 3rd-4th speed synchronizer hub |
| <> | 22. Synchronizer key |
| <> | 23. Synchronizer outer ring |
| <> | 24. Synchronizer cone |
| <> | 25. Synchronizer inner ring |
| <> >>B<< | 26. Thrust bearing |
| <> | 27. 3rd speed gear |
| | 28. Needle roller bearing |
| | >>B<< 29. Thrust bearing |
| <<C>> >>A<< | 30. Taper roller bearing |
| | 31. Input shaft |

Required Special Tools:

- | | |
|---|---------------------------------------|
| • MD998917: Bearing remover | • MD998813: Installer-100 |
| • MB990842: Drag link bushing remover and installer B | • MD998819: Installer adapter (40) |
| • MD998812: Installer cap | • MD998822: Installer adapter (46) |
| | • MD999601: Valve stem seal installer |

DISASSEMBLY SERVICE POINTS

<<A>> 5TH SPEED GEAR / SYNCHRONIZER INNER RING / SYNCHRONIZER CONE / SYNCHRONIZER OUTER RING / 5TH SPEED SYNCHRONIZER HUB / TAPER ROLLER BEARING / SYNCHRONIZER KEY STOPPER PLATE / 5TH SPEED SYNCHRONIZER SLEEVE REMOVAL

Using the special tools, MD998917 and MB990842, indicated below, remove the 5th speed gear, 5th speed synchronizer sleeve, 5th speed synchronizer hub, synchronizer inner ring, synchronizer outer ring, synchronizer cone, synchronizer key stopper plate and taper roller bearing.

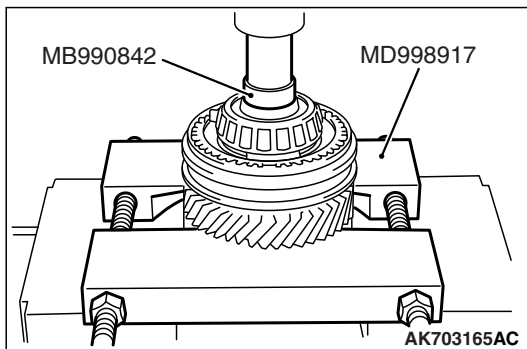

<> 3RD SPEED GEAR / 5TH SPEED GEAR SLEEVE / 4TH SPEED GEAR / NEEDLE ROLLER BEARING / 4TH SPEED GEAR SLEEVE / SYNCHRONIZER OUTER RING / SYNCHRONIZER CONE / SYNCHRONIZER INNER RING / 3RD-4TH SPEED SYNCHRONIZER SLEEVE / 3RD-4TH SPEED SYNCHRONIZER HUB / THRUST BEARING / 3RD SPEED GEAR REMOVAL

Using special tool, MD998917, support the 3rd speed gear, and then remove the 3rd speed gear, thrust bearings, 3rd-4th speed synchronizer sleeve, 3rd-4th speed synchronizer hub, synchronizer outer ring, synchronizer inner ring, synchronizer cone, 4th speed gear, needle roller bearing, 4th speed gear sleeve and 5th speed gear sleeve.

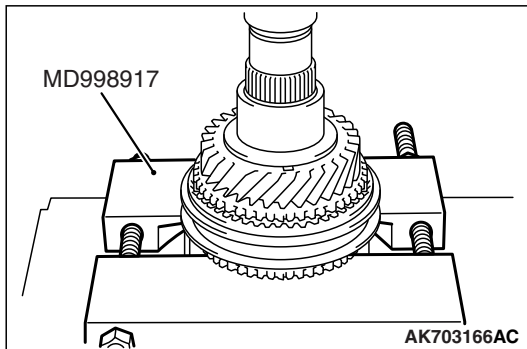

<<C>> TAPER ROLLER BEARING REMOVAL

Using special tool, MD998917, remove the taper roller bearing.

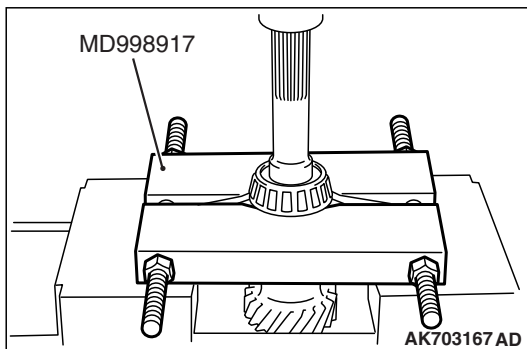

ASSEMBLY SERVICE POINTS

>>A<< TAPER ROLLER BEARING INSTALLATION

Using the special tools, MD998812, MD998813 and MD998819, indicated below, install the taper roller bearing.

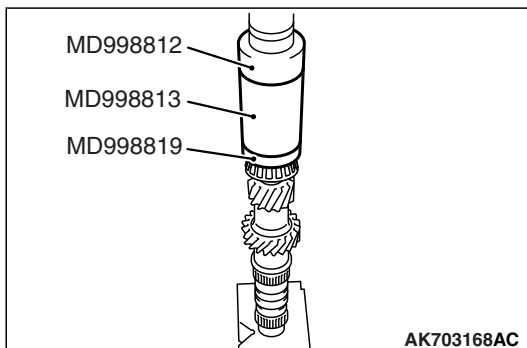

>>B<< THRUST BEARING INSTALLATION

Install the thrust bearings as shown.

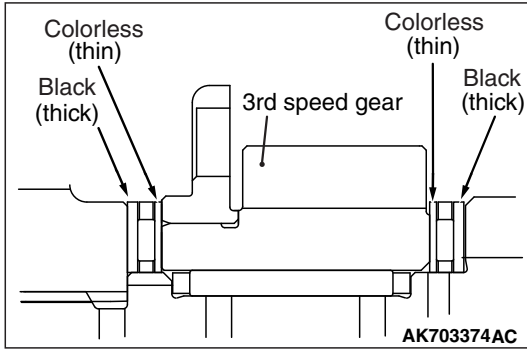

**>>C<< 3RD-4TH SPEED SYNCHRONIZER HUB /
3RD-4TH SPEED SYNCHRONIZER SLEEVE
INSTALLATION**

1. Install the 3rd-4th speed synchronizer hub and synchronizer sleeve in the illustrated direction.

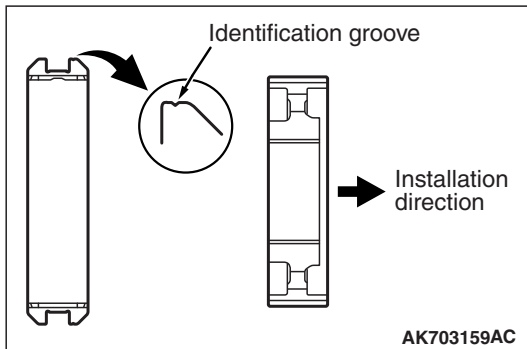

2. Using the special tools, MD998812, MD998813 and MD998822, indicated below, install the 3rd-4th speed synchronizer sleeve, 3rd-4th speed synchronizer hub, synchronizer outer ring, synchronizer inner ring and synchronizer cone.
3. After installation, check that the 3rd speed gear rotates smoothly.

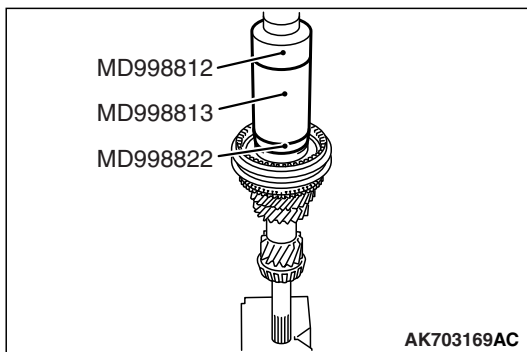

**>>D<< 4TH SPEED GEAR SLEEVE
INSTALLATION**

Using the special tools, MD998812, MD998813 and MD998822, indicated below, install the 4th speed gear sleeve.

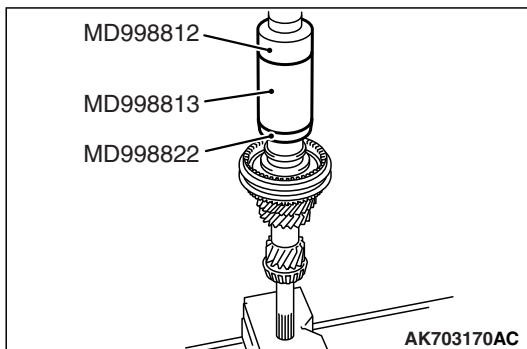

>>E<< 5TH SPEED GEAR SLEEVE INSTALLATION

Using the special tools, MD998812, MD998813 and MD998822, indicated below, install the 5th speed gear sleeve.

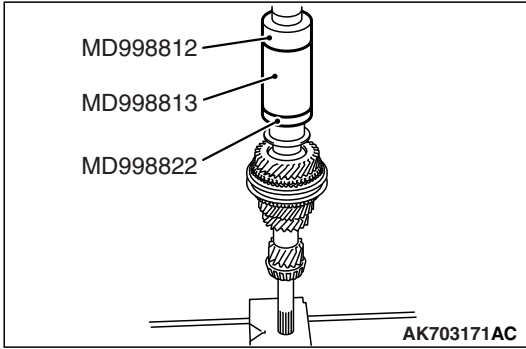

>>F<< 5TH SPEED SYNCHRONIZER HUB / 5TH SYNCHRONIZER SLEEVE INSTALLATION

1. Install the 5th speed synchronizer hub and synchronizer sleeve in the illustrated direction.

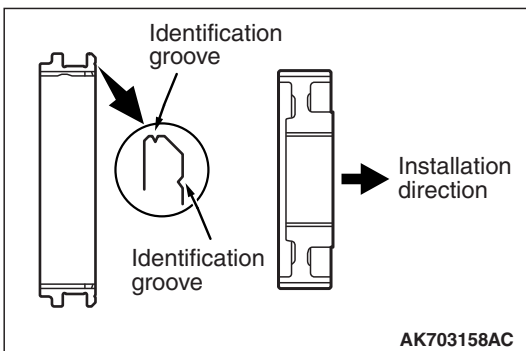

2. Using the special tools, MD998812, MD998813 and MD998822, indicated below, install the 5th speed synchronizer hub and synchronizer sleeve.
3. After installation, check that the 5th speed gear rotates smoothly.

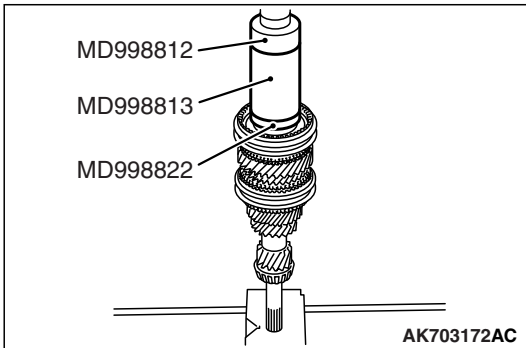

>>G<< TAPER ROLLER BEARING INSTALLATION

Using the special tools, MD998812, MD998813 and MD998822, indicated below, press-fit the taper roller bearing.

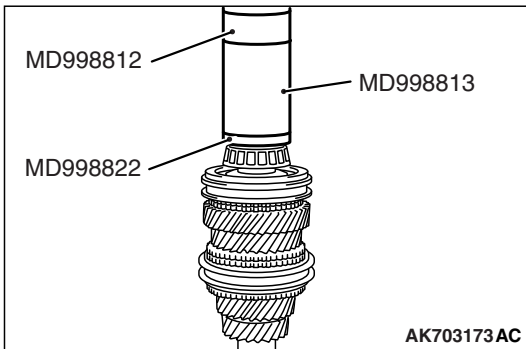

>>H<< SNAP RING INSTALLATION

Select and install appropriate snap ring onto the input shaft so that the clearance of the taper roller bearing meets the standard value.

Standard value: 0.01 –0.09 mm (0.0004 –0.0035 inch)

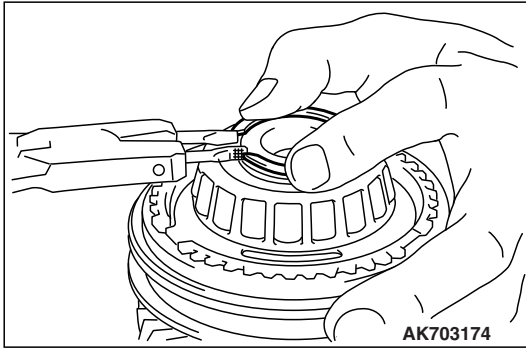

>>I<< OIL SEAL INSTALLATION

Using special tool, MD999601, drive the oil seal as deep as shown into place.

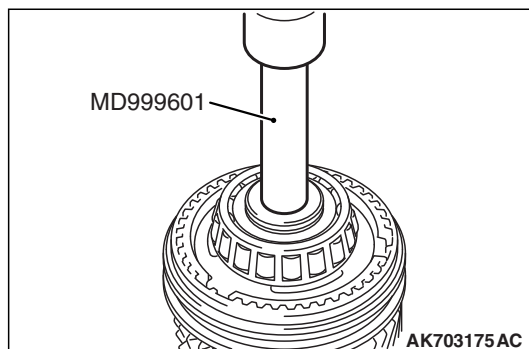
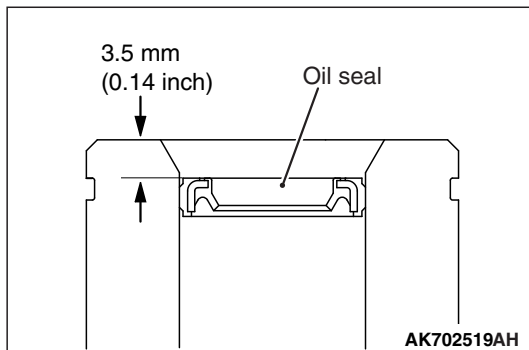

INSPECTION

M1222001700330

INPUT SHAFT

- Check the needle bearing mounting portion of the shaft for damage, wear and seizure.
- Check the splines for damage and wear.

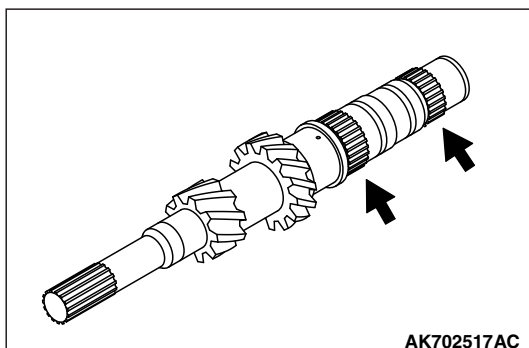

NEEDLE BEARING

- Combine the needle bearing with the input shaft and gears and check that it smoothly rotates without noise or play.
- Check the needle bearing retaining sleeve for deformation.

SPEED GEARS

1. Check that the helical and clutch gears of each speed gear are not damaged or worn in the tooth surface.
2. Check that the synchronizer cone of each speed gear is not roughened, damaged or worn in the surface.
3. Check that the inner, front and rear surfaces of each speed gear are not damaged or worn.

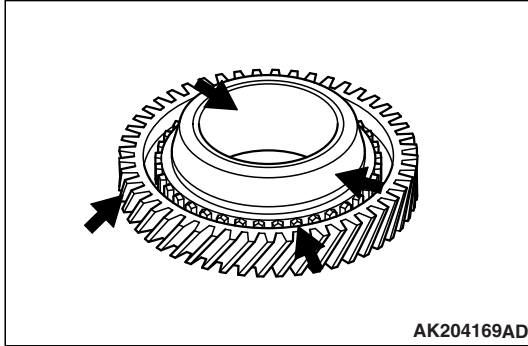
**SYNCHRONIZER RING**

1. Check that the outer synchronizer ring clutch gear is free of damage.
2. Check that the synchronizer rings and synchronizer cones are free of damage or wear in the contact surface and broken screw threads.
3. Check that the outer synchronizer ring and synchronizer key contact surface is free of damage and wear.

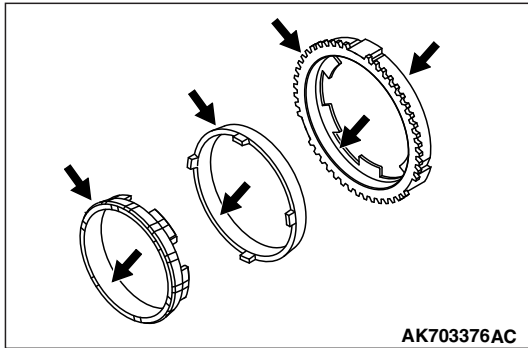

4. Join the outer and inner synchronizer rings and synchronizer cone together and check clearance "A" shown. If "A" is less than the limit value, replace them.

Limit A (from back of outer ring to clutch gear): 0.5 mm (0.02 inch)

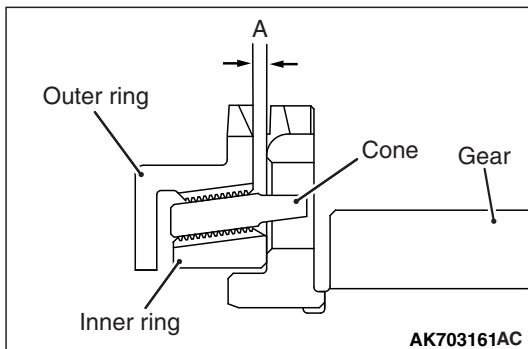
**SYNCHRONIZER SLEEVE AND HUB**

- Combine the synchronizer sleeve and hub, and check that they slide smoothly.
- Check that the sleeve is free of damage at its inside spline ends.

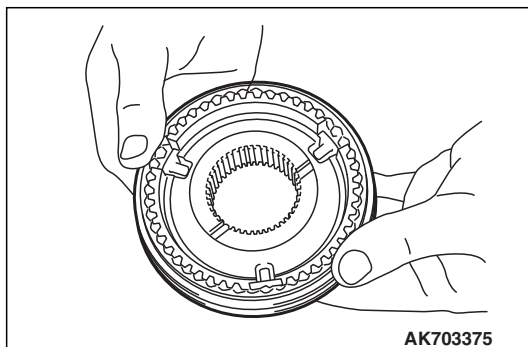

OUTPUT SHAFT

DISASSEMBLY AND ASSEMBLY

M1222002200640

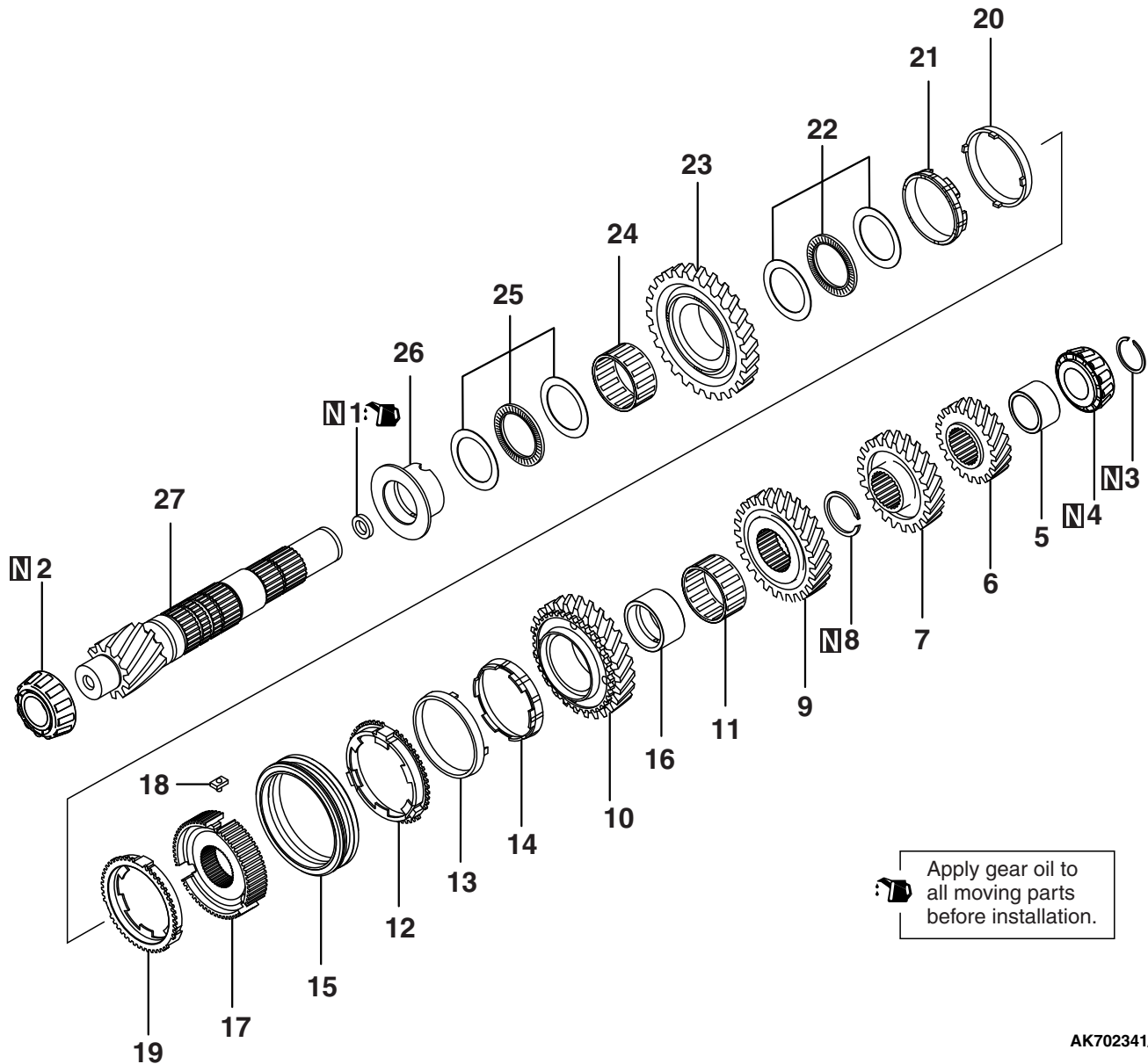

AK702341AC

- | | | | |
|--------------------------|--------------------------|-----------------------------|--------------------------|
| | >>M<< | Removal steps | |
| <<A>> | >>L<< | 1. Oil seal | |
| | >>K<< | 2. Taper roller bearing | |
| <> | >>J<< | 3. Snap ring | <<E>> |
| | | 4. Taper roller bearing | >>E<< |
| | | 5. Collar | <<E>> |
| <<C>> | >>I<< | 6. 5th speed gear | >>C<< |
| <<C>> | >>H<< | 7. 4th speed gear | |
| | >>G<< | 8. Snap ring | <<E>> |
| <<D>> | >>F<< | 9. 3rd speed gear | <<E>> |
| | | 10. 2nd speed gear | <<E>> |
| | | 11. Needle roller bearing | >>B<< |
| | | 12. Synchronizer outer ring | <<E>> |
| | | 13. Synchronizer cone | <<E>> |
| | | 14. Synchronizer inner ring | >>B<< |

- | | | |
|--|--------------------------|---------------------------------------|
| | >>D<< | Removal steps (Continued) |
| | | 15. 1st-2nd speed synchronizer sleeve |
| | | 16. 2nd speed gear sleeve |
| | | 17. 1st-2nd speed synchronizer hub |
| | | 18. Synchronizer key |
| | | 19. Synchronizer outer ring |
| | | 20. Synchronizer cone |
| | | 21. Synchronizer inner ring |
| | | 22. Thrust bearing |
| | | 23. 1st speed gear |
| | | 24. Needle roller bearing |
| | | 25. Thrust bearing |
| | | 26. 1st speed gear sleeve |
| | | 27. Output shaft |

Required Special Tools:

- MB990560: Rear axle shaft bearing remover
- MB990842: Drag link bushing remover and installer B
- MD998917: Bearing remover
- MD998812: Installer cap
- MD998814: Installer-200
- MD998824: Installer adapter (50)
- MD998822: Installer adapter (46)
- MD998813: Installer-100
- MD998821: Installer adapter (44)
- MD998819: Installer adapter (40)
- MD999601: Valve stem seal installer

DISASSEMBLY SERVICE POINTS**<<A>> TAPER ROLLER BEARING REMOVAL**

1. Using a chisel or the like, knock off the roller cage of the taper roller bearing.
2. Using the special tools, MB990842 and MB990560, indicated below, remove the taper roller bearing.

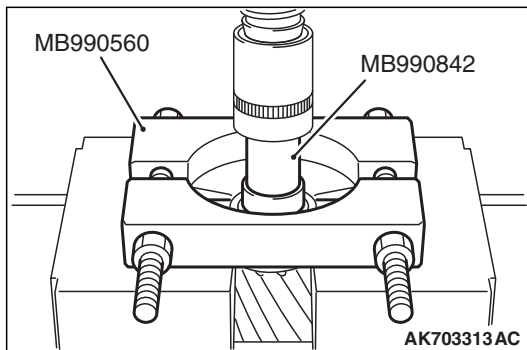
**<> TAPER ROLLER BEARING REMOVAL**

Using the special tools, MD998917 and MB990842, indicated below, remove the taper roller bearing.

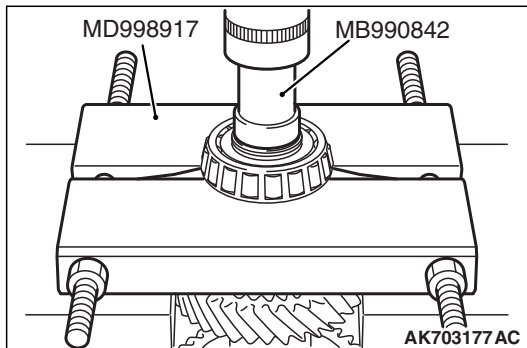
**<<C>> 5TH SPEED GEAR / 4TH SPEED GEAR REMOVAL**

Using the special tools, MD998917 and MB990842, indicated below, remove the 5th speed gear and 4th speed gear.

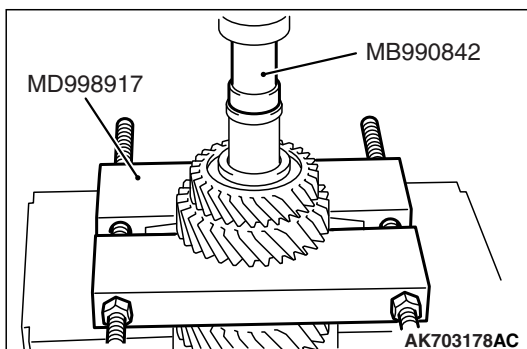

<<D>> 3RD SPEED GEAR REMOVAL

Using special tool, MD998917, remove the 3rd speed gear.

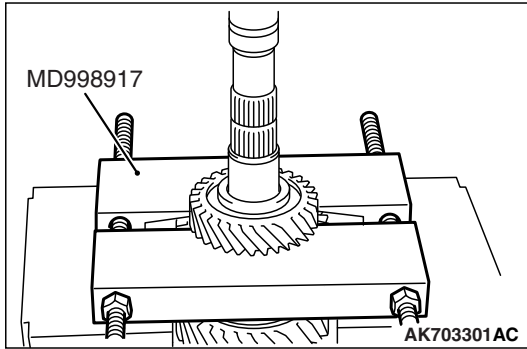

**<<E>> NEEDLE ROLLER BEARING /
SYNCHRONIZER CONE / SYNCHRONIZER
OUTER RING / SYNCHRONIZER INNER RING /
THRUST BEARING / 2ND SPEED GEAR SLEEVE /
1ST-2ND SPEED SYNCHRONIZER HUB / 1ST
SPEED GEAR / 1ST SPEED GEAR SLEEVE
REMOVAL**

Using special tool, MD998917, support the 1st speed gear sleeve, and then remove the 2nd speed gear sleeve, 1st-2nd speed synchronizer hub, synchronizer cones, synchronizer outer rings, synchronizer inner rings, thrust bearings, 1st speed gear, needle roller bearing and 1st speed gear sleeve.

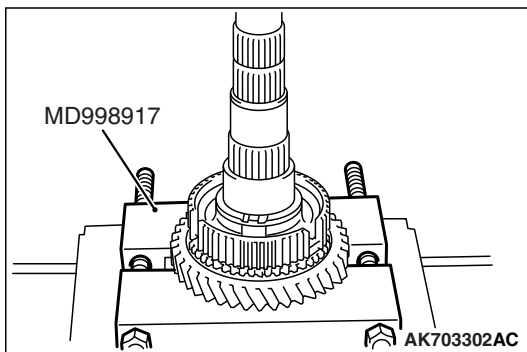

ASSEMBLY SERVICE POINTS

>>A<< 1ST SPEED GEAR SLEEVE INSTALLATION

Using the special tools, MD998812, MD998814 and MD998824, indicated below, install the 1st speed gear sleeve.

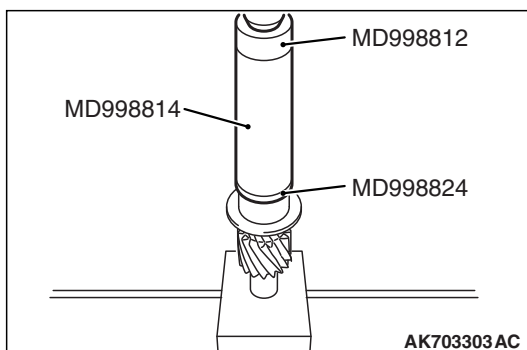

>>B<< THRUST BEARING INSTALLATION

Install the thrust bearings as shown.

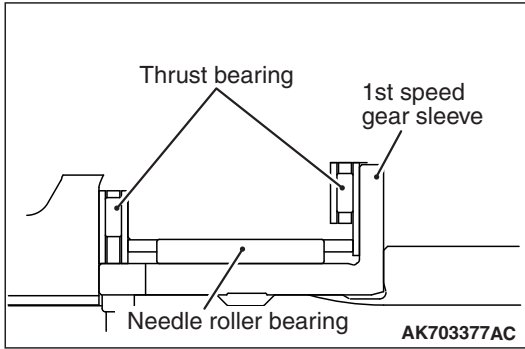
**>>C<< 1ST-2ND SPEED SYNCHRONIZER HUB INSTALLATION**

1. Install the 1st-2nd speed synchronizer hub in the illustrated direction.

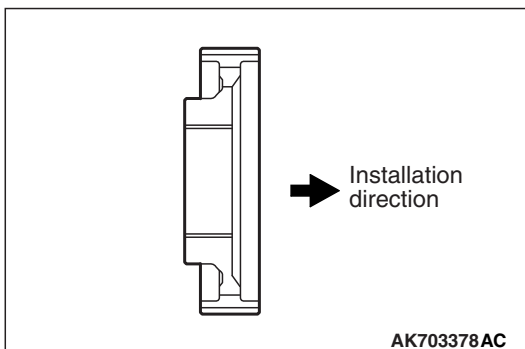

2. Using the special tools, MD998812, MD998814 and MD998824, indicated below, install the 1st-2nd speed synchronizer hub.

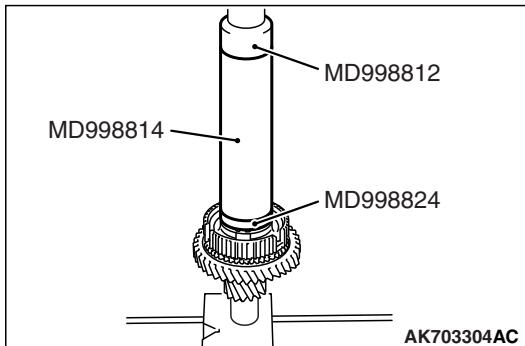
**>>D<< 1ST-2ND SPEED SYNCHRONIZER SLEEVE INSTALLATION**

1. Install the 1st-2nd speed synchronizer sleeve in the illustrated direction.
2. Install the synchronizer outer ring, synchronizer cone and synchronizer inner ring.
3. After installation, check that the 1st-2nd speed gears rotate smoothly.

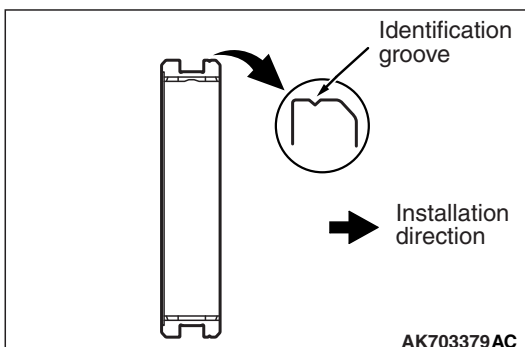

>>E<< 2ND SPEED GEAR SLEEVE INSTALLATION

Using the special tools, MD998812, MD998814 and MD998824, indicated below, install the 2nd speed gear sleeve.

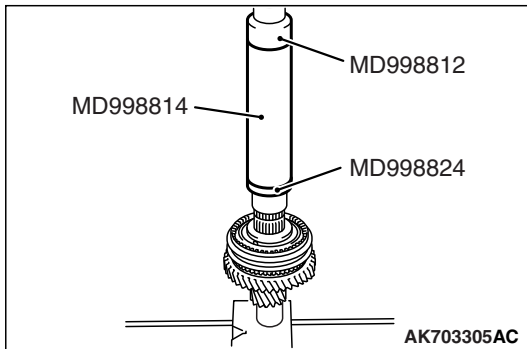

>>F<< 3RD SPEED GEAR INSTALLATION

Using the special tools, MD998812, MD998814 and MD998822, indicated below, install the 3rd speed gear.

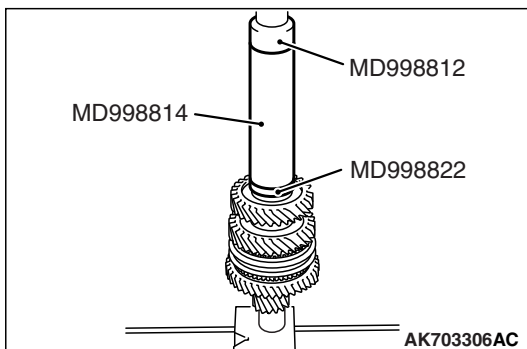

>>G<< SNAP RING INSTALLATION

Select and install appropriate snap ring onto the output shaft so that the clearance of the output shaft-3rd speed gear meets the standard value.

Standard value: 0.01 –0.09 mm (0.0004 –0.0035 inch)

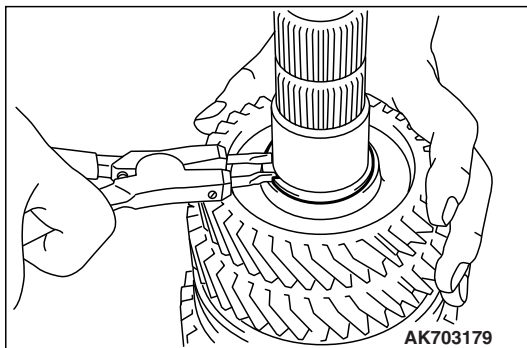

>>H<< 4TH SPEED GEAR INSTALLATION

Using the special tools, MD998812, MD998813 and MD998821, indicated below, install the 4th speed gear.

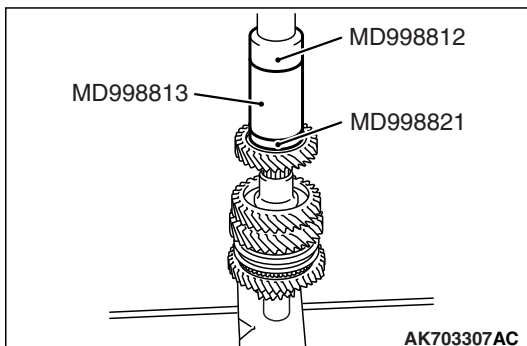

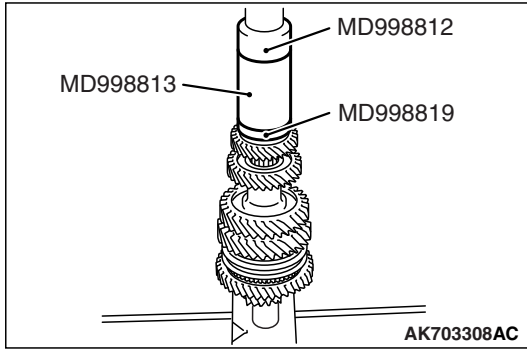

>>I<< 5TH SPEED GEAR INSTALLATION

Using the special tools, MD998812, MD998813 and MD998819, indicated below, install the 5th speed gear.

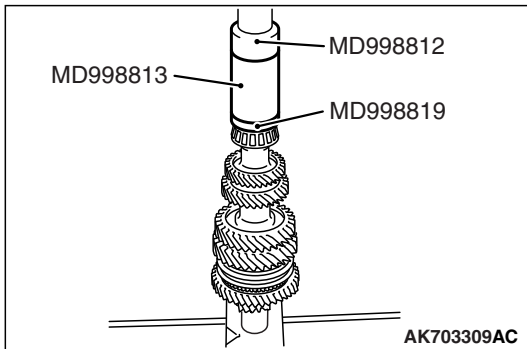

>>J<< TAPER ROLLER BEARING INSTALLATION

Using the special tools, MD998812, MD998813 and MD998819, indicated below, press-fit the taper roller bearing.

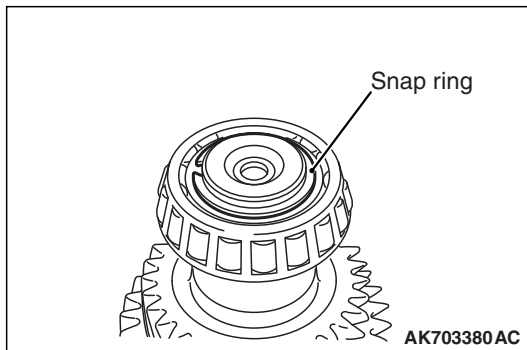

>>K<< SNAP RING INSTALLATION

Select and install appropriate snap ring onto the output shaft so that the clearance of the taper roller bearing meets the standard value.

Standard value: 0.01 –0.09 mm (0.0004 –0.0035 inch)

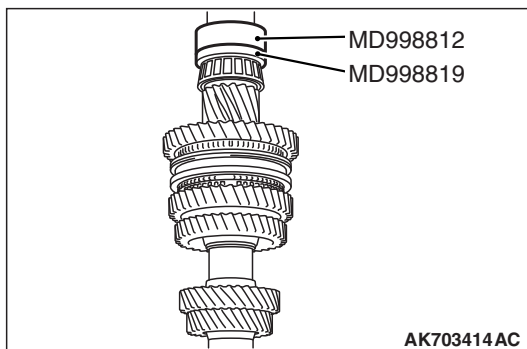

>>L<< TAPER ROLLER BEARING INSTALLATION

Using the special tools, MD998812 and MD998819, indicated below, install the taper roller bearing.

>>M<< OIL SEAL INSTALLATION

Using special tool, MD999601, drive the oil seal as deep as shown into place.

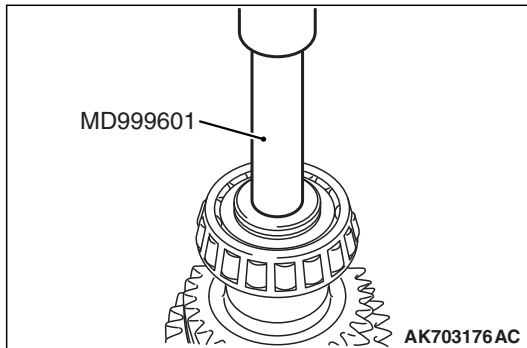
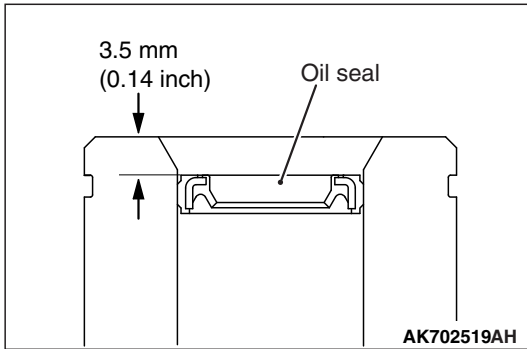

INSPECTION

M1222002300294

OUTPUT SHAFT

- Check the needle bearing mounting portion of the shaft for damage, wear and seizure.
- Check the splines for damage and wear.

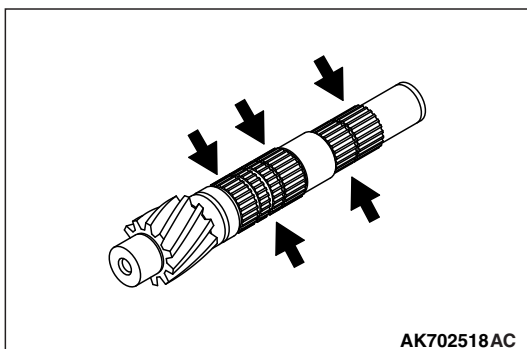

NEEDLE BEARING

- Combine the needle bearing with the input shaft and gears and check that it smoothly rotates without noise or play.
- Check the needle bearing retaining sleeve for deformation.

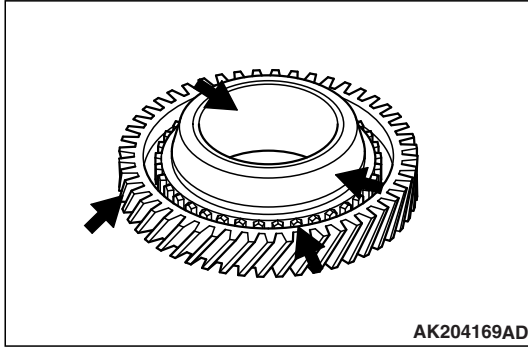

SPEED GEARS

1. Check that the helical and clutch gears of each speed gear are not damaged or worn in the tooth surface.
2. Check that the synchronizer cones of the 1st and 2nd speed gears are not roughened, damaged or worn in the surface.
3. Check that the inner, front and rear surfaces of each speed gear are not damaged or worn.

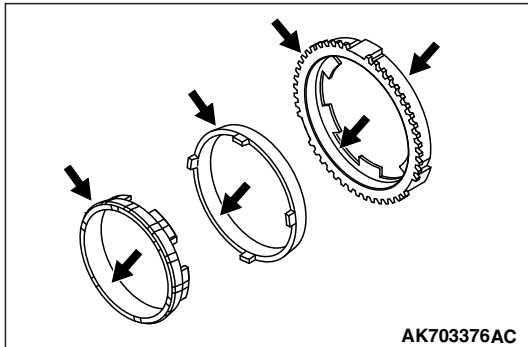

SYNCHRONIZER RING

1. Check that the outer synchronizer ring clutch gear is free of damage.
2. Check that the synchronizer rings and synchronizer cones are free of damage or wear in the contact surface and broken screw threads.
3. Check that the outer synchronizer ring and synchronizer key contact surface is free of damage and wear.

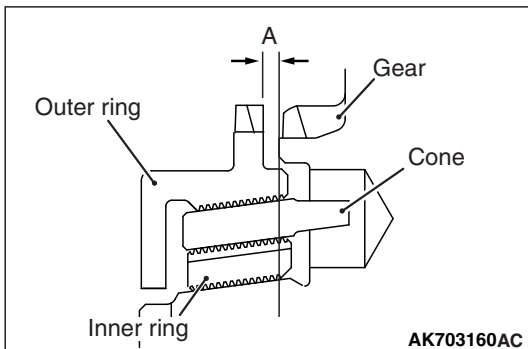

4. Join the outer and inner synchronizer rings and synchronizer cone together and check clearance "A" shown. If "A" is less than the limit value, replace them.

Limit A (from back of outer ring to clutch gear): 0.5 mm (0.02 inch)

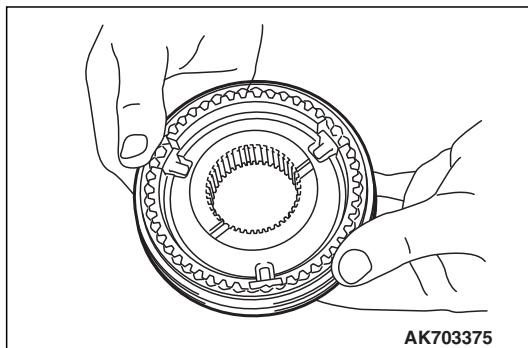

SYNCHRONIZER SLEEVE AND HUB

- Combine the synchronizer sleeve and hub, and check that they slide smoothly.
- Check that the sleeve is free of damage at its inside spline ends.

REVERSE IDLER GEAR

DISASSEMBLY AND ASSEMBLY

M1222012500329

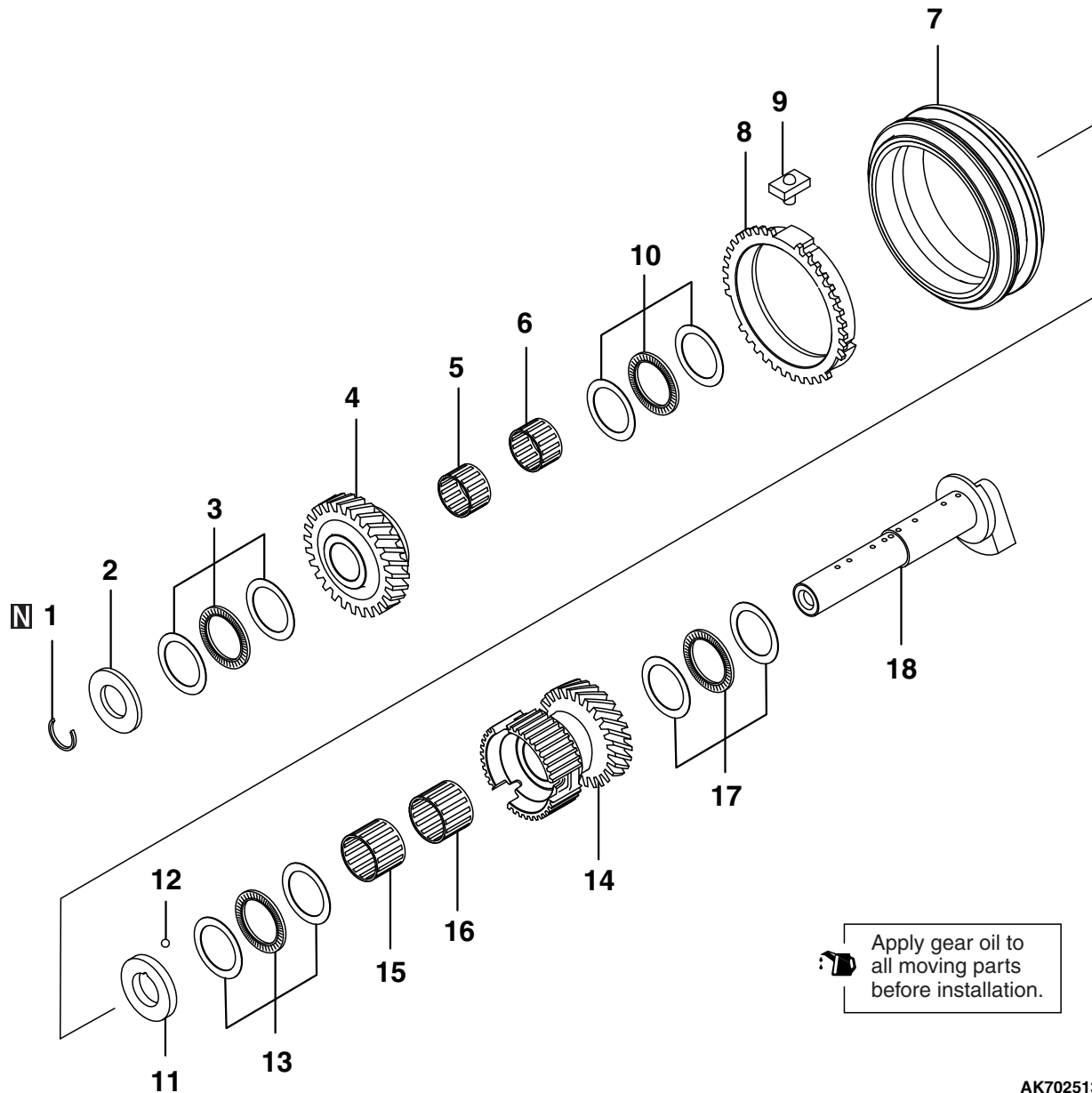

Apply gear oil to all moving parts before installation.

AK702513AC

- >>C<<**
- Removal steps**
1. Snap ring
 2. Thrust washer A
 3. Thrust bearing
 4. Reverse idler gear A
 5. Needle bearing
 6. Needle bearing
- >>B<<**
7. Synchronizer sleeve
 8. Synchronizer ring
 9. Synchronizer key

- Removal steps (Continued)**
10. Thrust bearing
 11. Thrust washer B
 12. Steel ball
 13. Thrust bearing
 14. Reverse idler gear B
 15. Needle bearing
 16. Needle bearing
 17. Thrust bearing
 18. Reverse idler gear shaft
- >>A<<**
- >>A<<**

DISASSEMBLY SERVICE POINTS**>>A<< THRUST BEARING INSTALLATION**

Install the thrust bearing as shown.

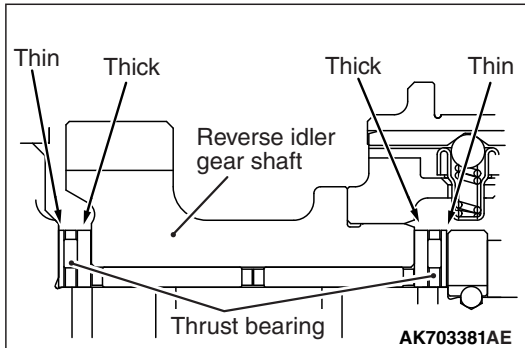
**>>B<< SYNCHRONIZER SLEEVE INSTALLATION**

Install the synchronizer sleeve in the illustrated direction.

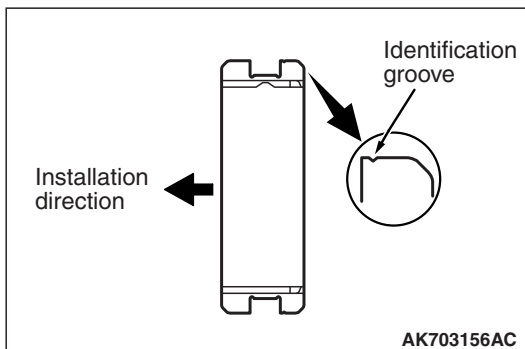
**>>C<< SNAP RING INSTALLATION**

.Select and install appropriate snap ring onto the reverse idler gear shaft so that the clearance of the thrust washer A meets the standard value.

Standard Value: 0 –0.11 mm (0 –0.0043 inch)

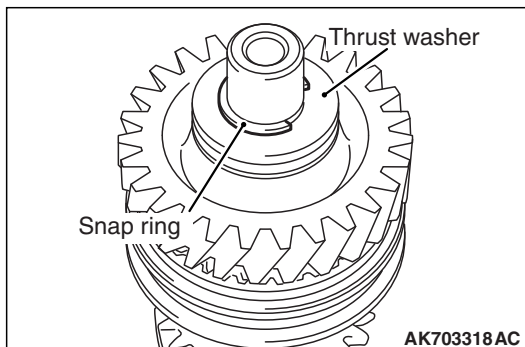

INSPECTION

M1222012400117

REVERSE IDLER GEAR

1. Check that the synchronizer ring clutch gear teeth are free of damage.
2. Check that the inside surface of the synchronizer ring cone is free of damage and wear.
3. Check that the synchronizer ring and synchronizer key are not damaged or worn in the contact surface.
4. Press the synchronizer ring against the gear and check clearance "A". If "A" is less than the limit value, replace the synchronizer ring.

Limit: 0.5 mm (0.02 inch)

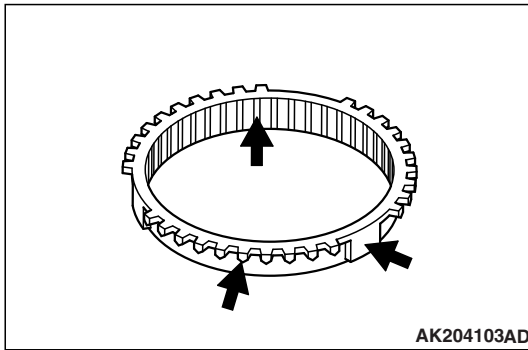

NEEDLE BEARING

1. Assemble the needle bearing with the reverse idler shaft and gear, and check that the bearing rotates smoothly without noise or play.
2. Check that needle bearing retaining sleeve for deformation.

REVERSE IDLER GEAR

1. Check that the helical gear and the tooth surfaces of the clutch gear of the reverse idler gear A are free of damage or wear.
2. Check that the synchronizer ring of the reverse idler gear A is not roughened, damaged or worn in the surface.
3. Check that the helical gear of the reverse idler gear is free of damage or wear.

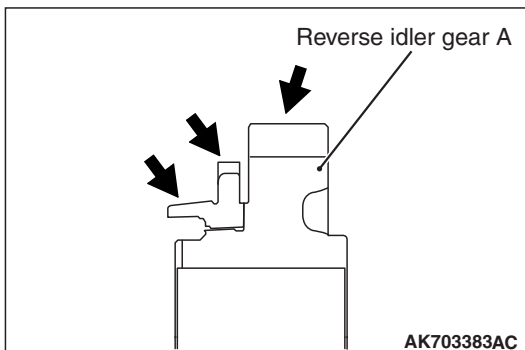

DISASSEMBLY SERVICE POINTS

<<A>> LOCK PIN REMOVAL

Drive out the lock pin in the direction shown.

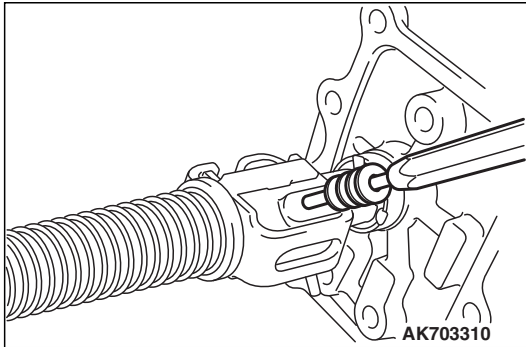

<> OIL SEAL REMOVAL

Using special tool, MD999566, remove the oil seal.

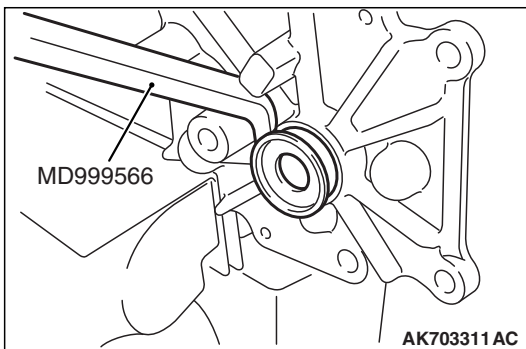

<<C>> SLIDE BALL BEARING REMOVAL

Using special tool, MB990947, remove the slide ball bearing.

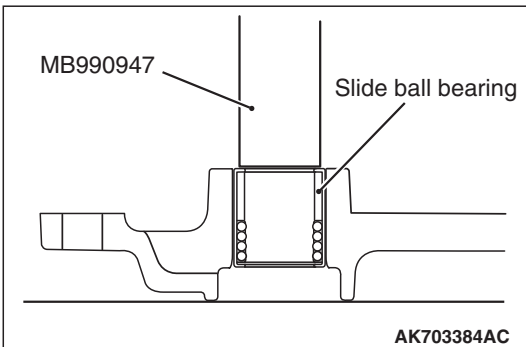

ASSEMBLY SERVICE POINTS

>>A<< SLIDE BALL BEARING INSTALLATION

Using special tool, MB990984, install the slide ball bearing in alignment with the control housing end face taking care not to let the bearing protrude to the oil seal installing surface.

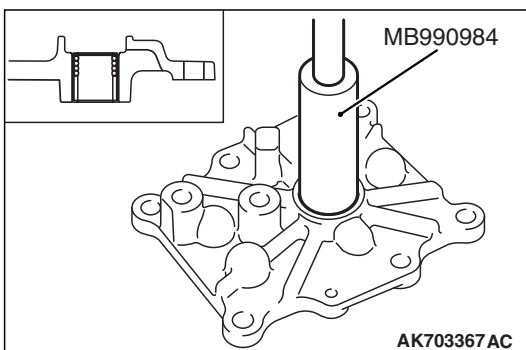

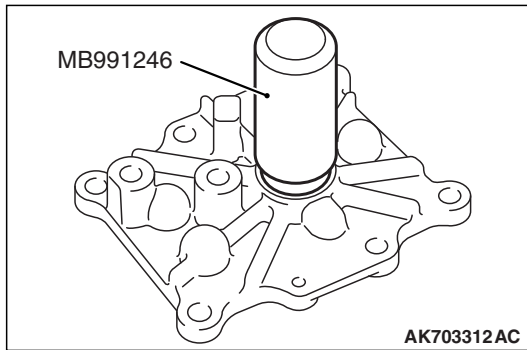
**>>B<< OIL SEAL INSTALLATION**

1. Using special tool, MB991246, install the oil seal.
2. Apply specified transmission oil to the oil seal lip area.

**Specified transaxle oil: Mitsubishi Genuine DiaQueen
New Multi Gear oil SAE 75W-80 (GL-3)**

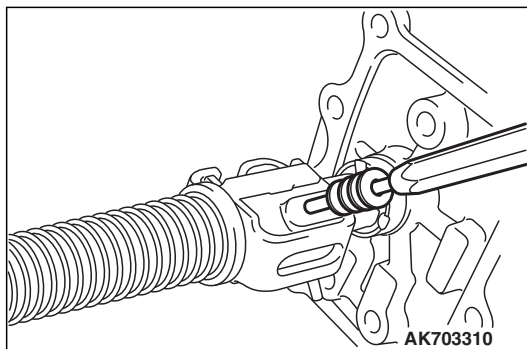
**>>C<< LOCK PIN INSTALLATION**

Drive the lock pin all the way into place to the end face from the illustrated direction.

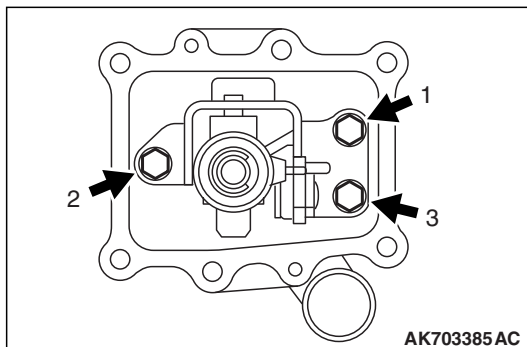
**>>D<< STOPPER BRACKET INSTALLATION**

Tighten the stopper bracket mounting bolts to the specified torque in the illustrated order.

SELECT LEVER

DISASSEMBLY AND ASSEMBLY

M1222012800386

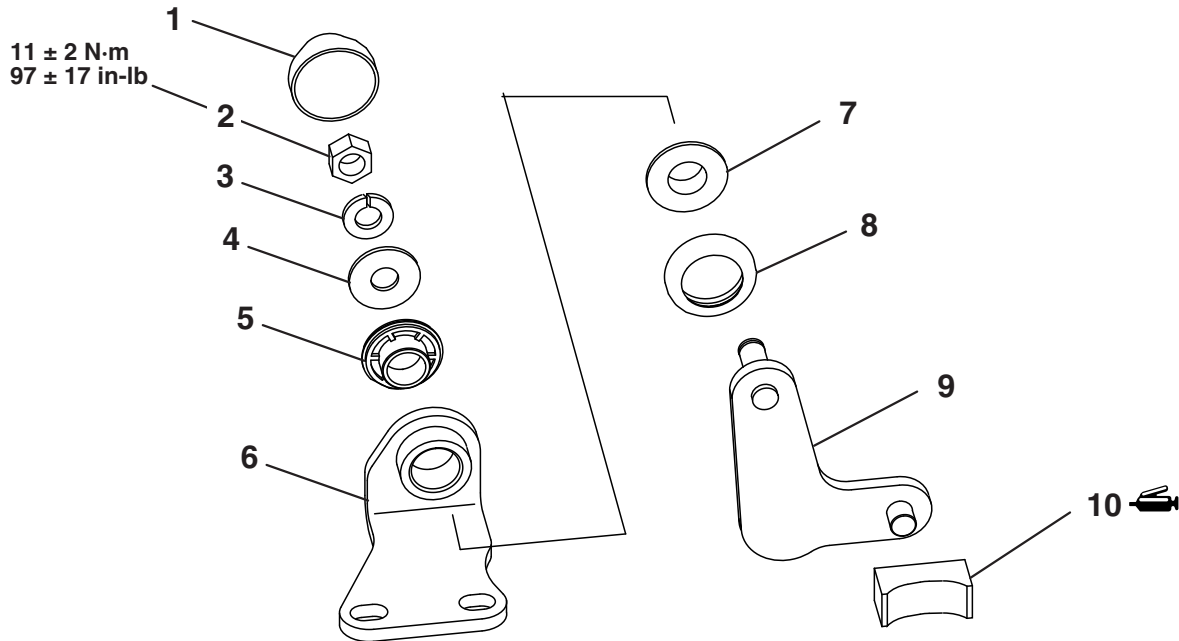

- Removal steps**
1. Dust cover
 2. Nut
 3. Spring washer
 4. Washer
 5. Select lever bushing

- AK703152AC
- Removal steps (Continued)**
6. Select lever bracket
 7. Select lever bushing
 8. Dust cover
 9. Select lever
 10. Select lever shoe

>>A<<

ASSEMBLY SERVICE POINTS

>>A<< SELECT LEVER SHOE INSTALLATION

Apply specified grease to the sliding contact surface of the select lever shoe.

Specified grease: Mitsubishi Part No. 0101011 or equivalent

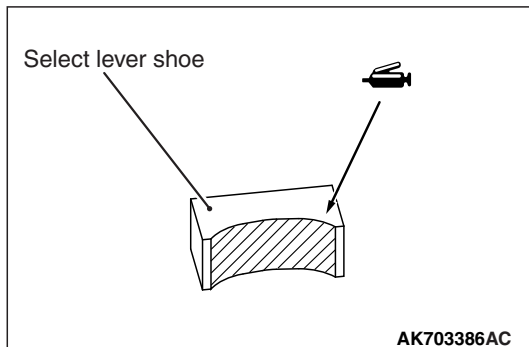

CLUTCH HOUSING

DISASSEMBLY AND ASSEMBLY

M1222003700660

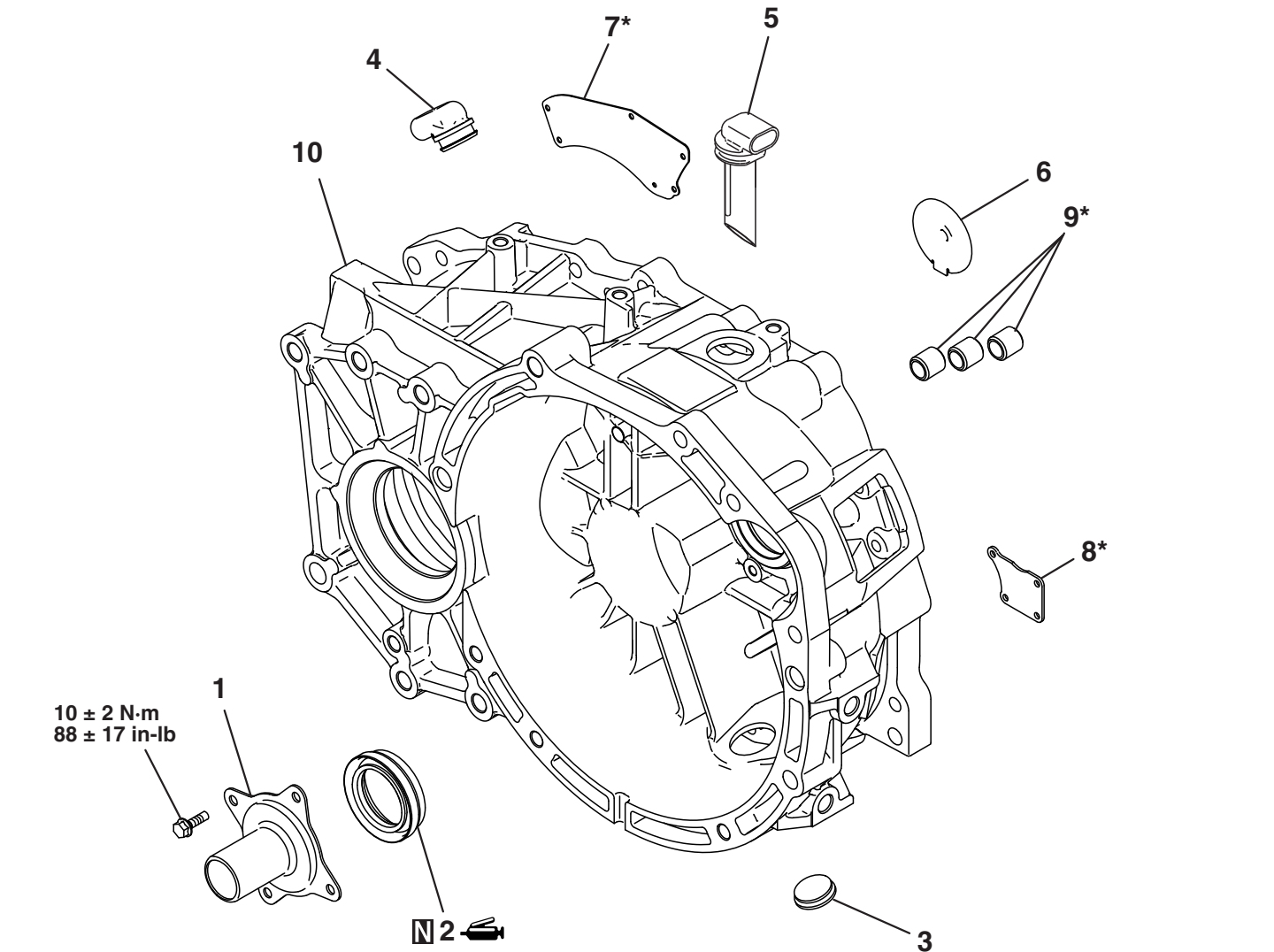

AK702515AC

Removal steps

- >>D<< 1. Clutch release bearing retainer
- >>D<< 2. Oil seal
- >>D<< 3. Maintenance hole cover
- >>D<< 4. Cover A
- >>D<< 5. Cover B
- <<A>> >>C<< 6. Output front oil guide
- >>B<< 7. Oil tank cover (CHG)*

Removal steps (Continued)

- >>B<< 8. Oil tank cover (REV)*
- >>A<< 9. Slide ball bearing (for shift rail)*
- >>A<< 10. Clutch housing

NOTE: *Refer to the assembly service points only when the clutch housing is replaced.

Required Special Tools:

- MB991946: Ply bar
- MB990883: Rear suspension bushing arbor
- MD999547: Oil seal installer
- MB992271: Oil seal installer
- MB992075: Handle

DISASSEMBLY SERVICE POINTS

<<A>> OUTPUT FRONT OIL GUIDE REMOVAL

Using special tool, MB991946, remove the output front oil guide.

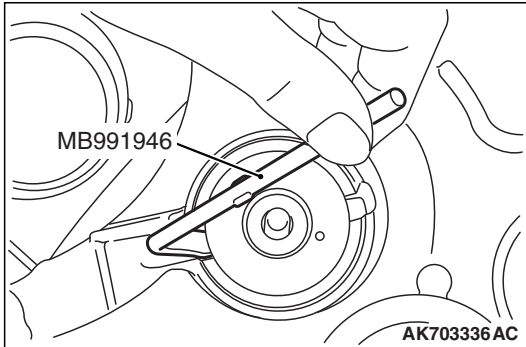

ASSEMBLY SERVICE POINTS

>>A<< SLIDE BALL BEARING (FOR SHIFT RAIL) INSTALLATION

⚠ CAUTION

- Normally, it is not necessary to disassemble the slide ball bearings. Install them only when the clutch housing is replaced with a new one.
- Install the bearing with the stamped mark facing upward.

Using special tool, MB990883, install the slide ball bearings on the new clutch housing.

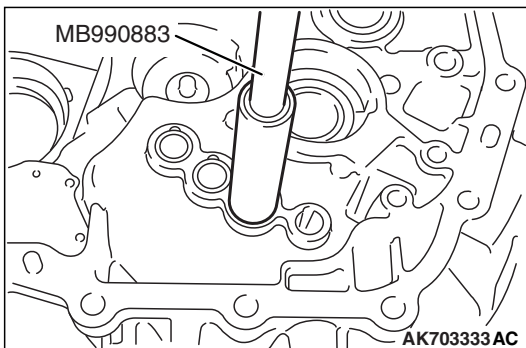

>>B<< OIL TANK COVER (REV) / OIL TANK COVER (CHG) INSTALLATION**⚠ CAUTION**

Normally, it is not necessary to disassemble the oil tank covers. Install them only when the clutch housing is replaced with a new one.

Install the oil tank covers to the new clutch housing. Stake the projections at the illustrated positions of the clutch housing to secure the covers in position.

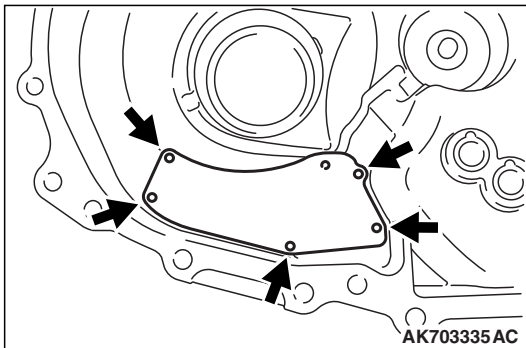
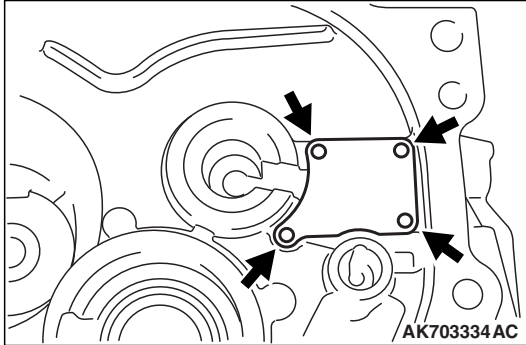
**>>C<< OUTPUT FRONT OIL GUIDE INSTALLATION****⚠ CAUTION**

Make sure that the output front oil guide is installed squarely.

Using special tool, MD999547, drive the oil guide all the way into place to the end face of the clutch housing.

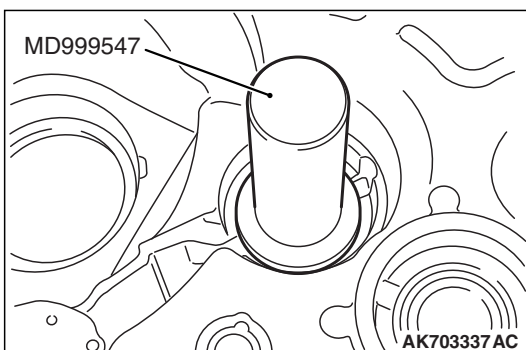

>>D<< OIL SEAL INSTALLATION

1. Using special tool, MB992271 and MB992075, drive the oil seal squarely into the clutch housing.

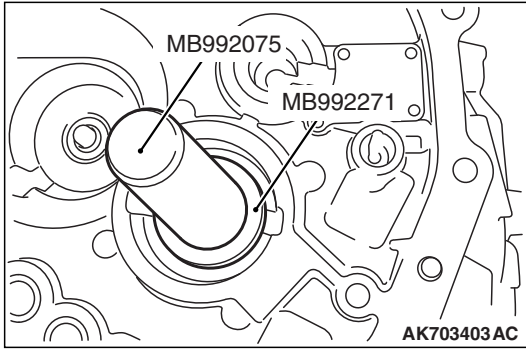

2. Apply specified grease to the oil seal lip area.
Specified grease: Retinax A

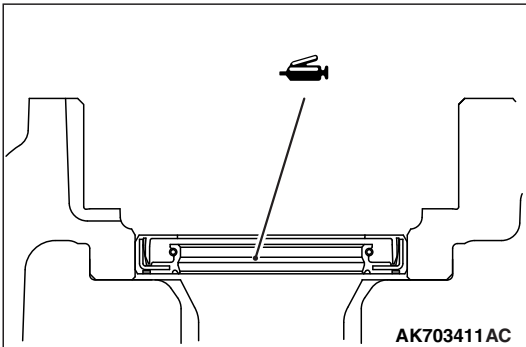

TRANSAXLE CASE

DISASSEMBLY AND ASSEMBLY

M1222016300060

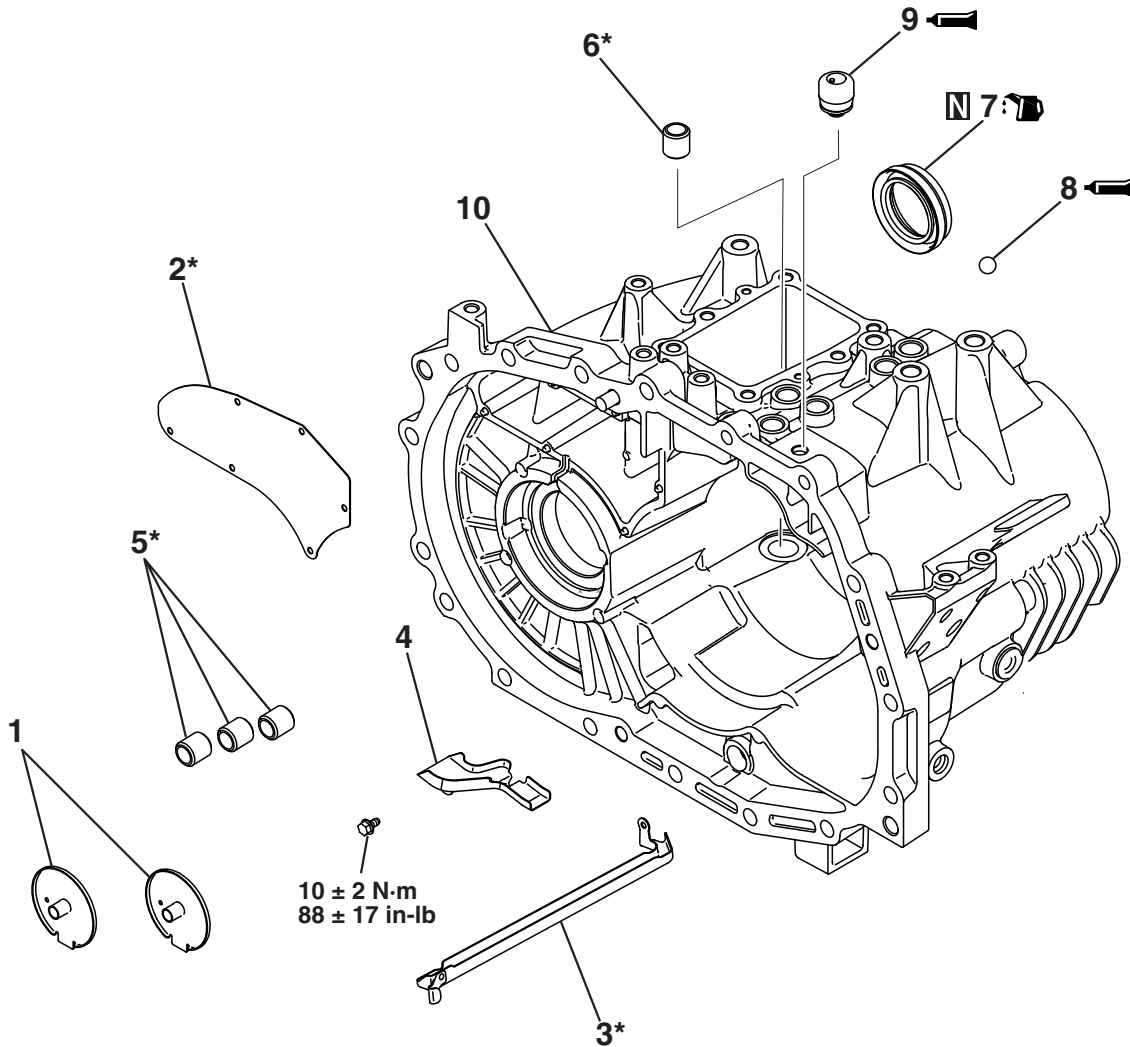

AK705042AC

- | | | |
|-------|-------|--|
| <<A>> | >>H<< | 1. Oil guide |
| | >>G<< | 2. Oil tank cover * |
| | >>F<< | 3. Oil guide A* |
| | >>E<< | 4. Oil guide B |
| | >>D<< | 5. Slide ball bearing (for shift rail)* |
| | >>C<< | 6. Slide ball bearing (for control shaft)* |
| | | 7. Oil seal |

- | | |
|-------|--------------------|
| >>B<< | 8. Steel ball |
| >>A<< | 9. Air breather |
| | 10. Transaxle case |

*NOTE: *: Refer to the assembly service points only when the transaxle case is replaced.*

Required Special Tools:

- MB991946: Ply bar
- MB990883: Rear suspension bushing arbor
- MB991115: Oil seal installer
- MB990938: Installer bar
- MD999547: Oil seal installer

DISASSEMBLY SERVICE POINTS

<<A>> OIL GUIDE REMOVAL

Using special tool, MB991946, remove the oil guides from the transaxle case.

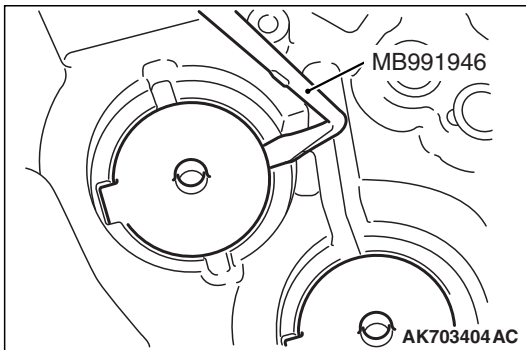

ASSEMBLY SERVICE POINTS

>>A<< AIR BREATHER INSTALLATION

1. Apply specified sealant to the periphery of the air breather insertion part.
Specified sealant: Three bond 1501 or equivalent
2. Install the air breather to the transaxle case in accordance with the illustrated identification mark.

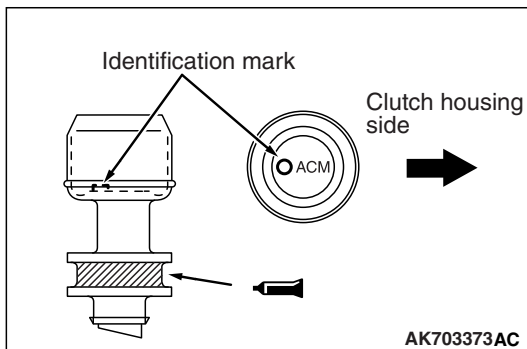

>>B<< STEEL BALL INSTALLATION

1. Apply specified sealant to the periphery of the transaxle case where the steel ball is installed, then install the steel ball onto the transaxle case.
Specified sealant: 3M™STUD Locking No.4710 or equivalent

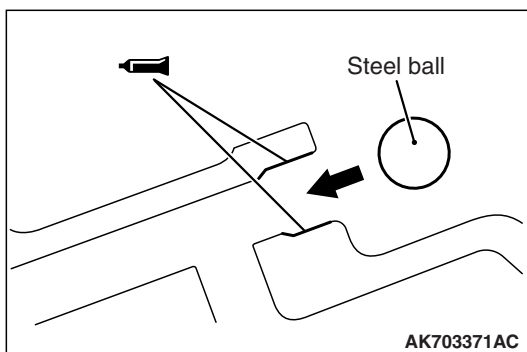

2. Using special tool, MB990883, install the steel ball.

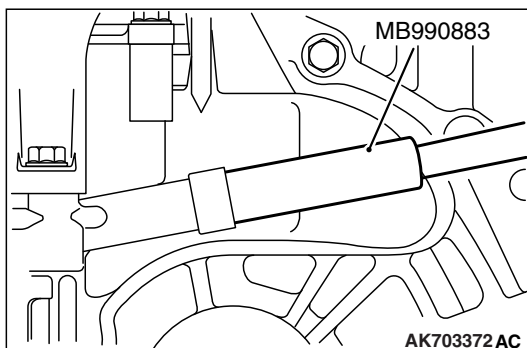

>>C<< OIL SEAL INSTALLATION

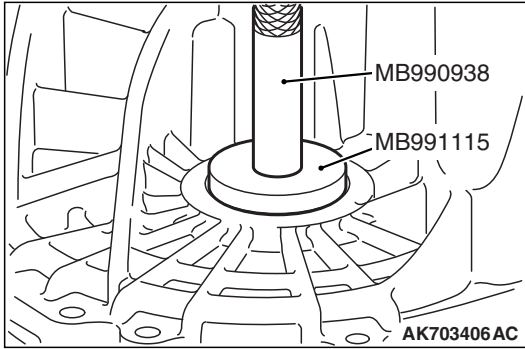

1. Using the special tools, MB991115 and MB990938, indicated below, install the oil seal to the transaxle case.

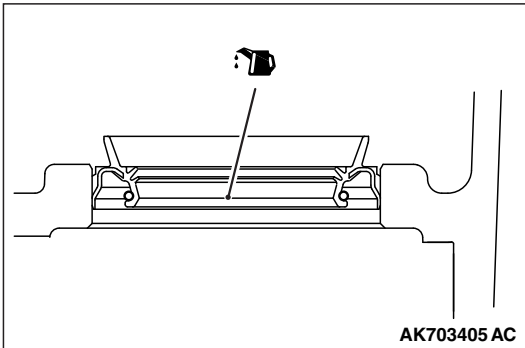

2. Apply specified transaxle oil to the oil seal lip area.

**Specified transaxle oil: Mitsubishi Genuine DiaQueen
New Multi Gear Oil SAE 75W-80 (GL-3)**

>>D<< SLIDE BALL BEARING (FOR CONTROL SHAFT) INSTALLATION

⚠ CAUTION

- Normally, it is not necessary to disassemble the slide ball bearing. Install it only when the transaxle case is replaced with a new one.
- Install the bearing with the stamped mark facing upward.

Using special tool, MB990883, install the slide ball bearing (for control shaft) to the new transaxle case.

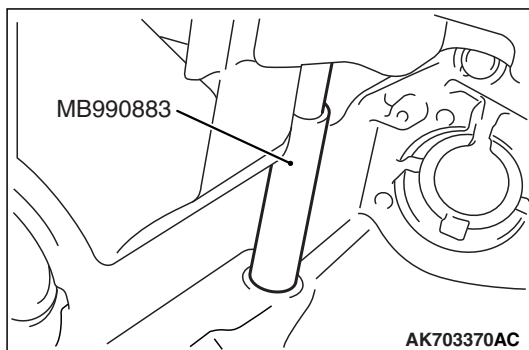

>>E<< SLIDE BALL BEARING (FOR SHIFT RAIL) INSTALLATION

⚠ CAUTION

- Normally, it is not necessary to disassemble the slide ball bearing. Install it only when the transaxle case is replaced with a new one.
- Install the bearing with the stamped mark facing upward.

Using special tool, MB990883, install the slide ball bearing (for shift rail) to the new transaxle case.

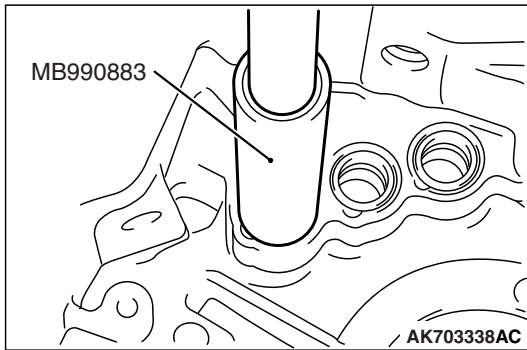

>>F<< OIL GUIDE A INSTALLATION

⚠ CAUTION

Normally, it is not necessary to disassemble the oil guide A. Install the oil guide only when the transaxle case is replaced with a new one.

Install the oil guide A to the new transaxle case. Stake at the illustrated point to secure the oil guide in position.

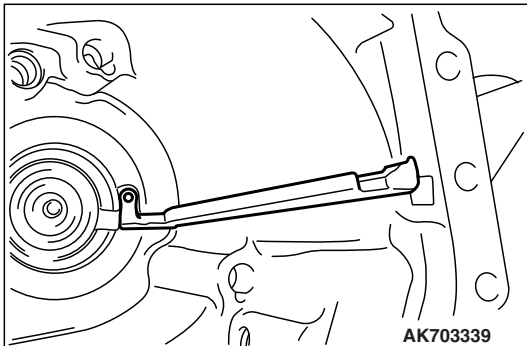

>>G<< OIL TANK COVER INSTALLATION

⚠ CAUTION

Normally, it is not necessary to disassemble the oil tank cover. Install the cover only when the transaxle case is replaced with a new one.

Install the oil tank cover onto the new transaxle case. Stake at the illustrated six points to secure the cover in position.

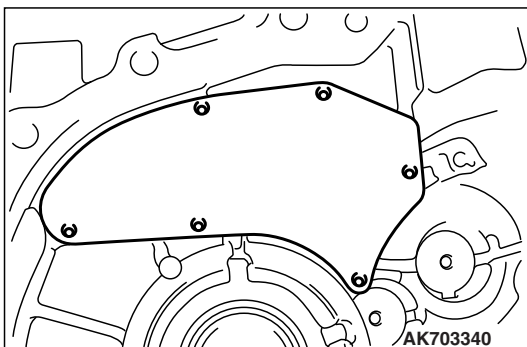

>>H<< OIL GUIDE INSTALLATION

CAUTION

Install the oil guide squarely.

Using special tool, MD999547, drive the oil guide all the way into place to the end face of the transaxle case.

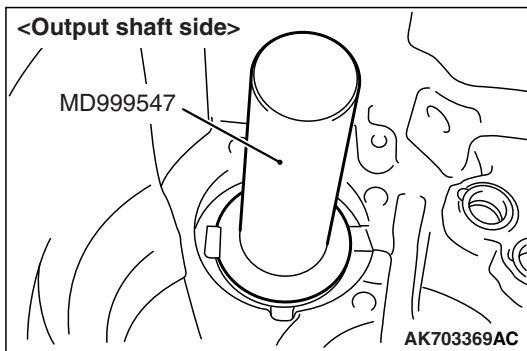
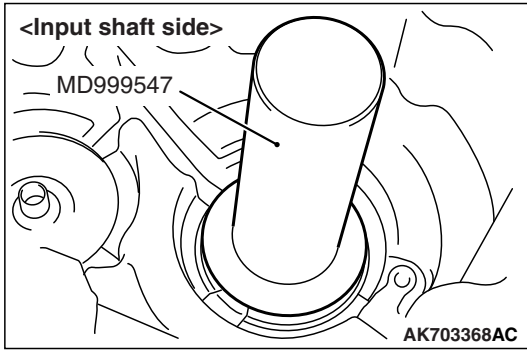

CENTER DIFFERENTIAL

DISASSEMBLY AND ASSEMBLY

M1222010600104

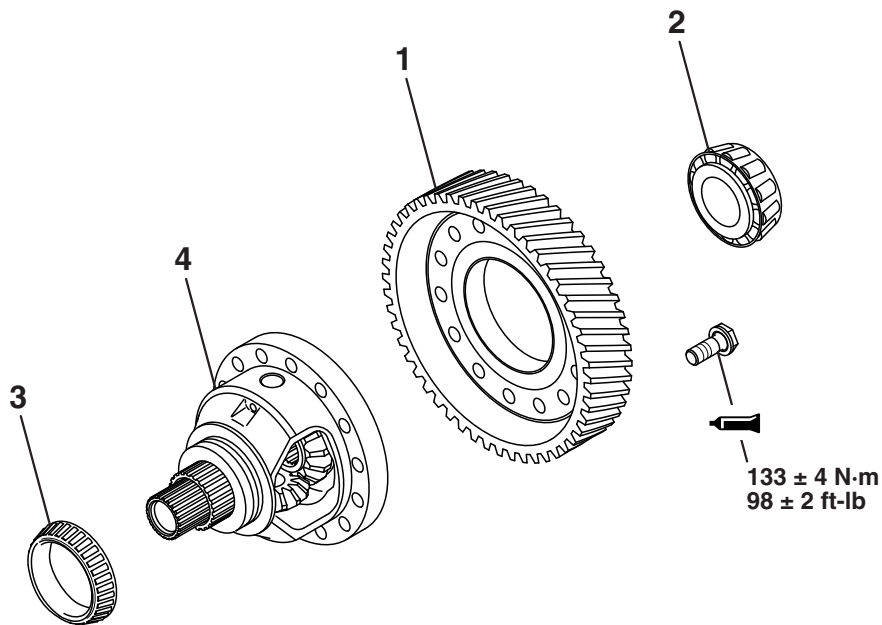

AK703150 AC

Removal steps

1. Center differential drive gear
2. Taper roller bearing

Removal steps (Continued)

3. Taper roller bearing
4. Center differential assembly

<<A>> >>C<<
>>B<<

<> >>A<<

Required Special Tools:

- MD998917: Bearing remover
- MD999547: Oil seal installer
- MD998812: Installer cap
- MD998813: Installer-100
- MD998830: Installer adapter (66)
- MD992272: Bearing installer
- MB990847: Rear suspension bushing remover and installer base

DISASSEMBLY SERVICE POINTS

<<A>> TAPER ROLLER BEARING REMOVAL

1. Using a chisel or the like, knock off the roller cage of the taper roller bearing.
2. Using the special tools, MD998917 and MD999547, indicated below, remove the taper roller bearing.

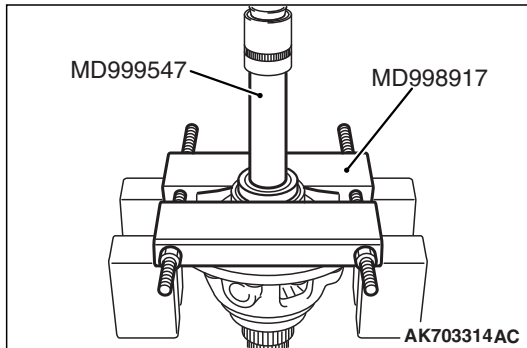

<> TAPER ROLLER BEARING REMOVAL

1. Using a chisel or the like, knock off the roller cage of the taper roller bearing.
2. Using the special tools, MD998917, MD998812, MD998813 and MD998830, indicated below, remove the taper roller bearing.

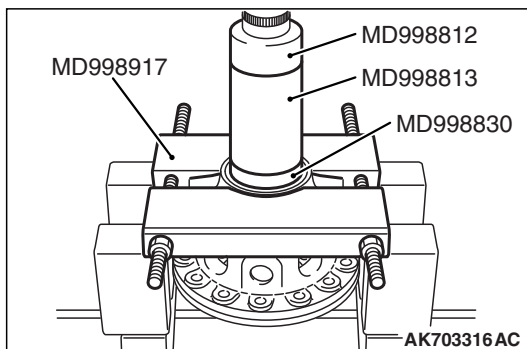

ASSEMBLY SERVICE POINTS

>>A<< TAPER ROLLER BEARING INSTALLATION

Using special tool, MB992272, install the taper roller bearing.

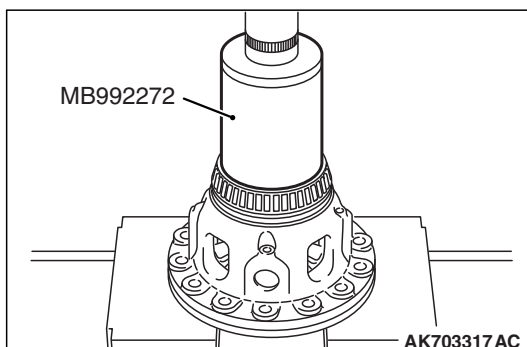

>>B<< TAPER ROLLER BEARING INSTALLATION

Using special tool, MB990847, install the taper roller bearing.

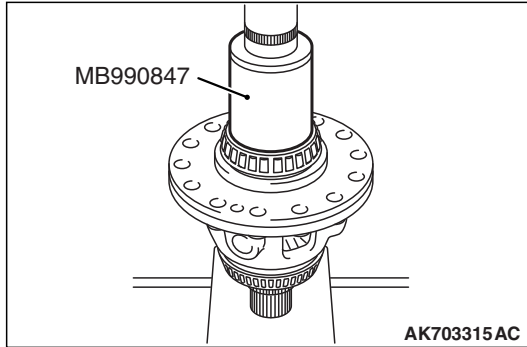

>>C<< CENTER DIFFERENTIAL DRIVE GEAR INSTALLATION

1. Apply specified sealant to the entire threaded portion of the bolt.

Specified sealant: 3M™STUD Locking No.4710 or equivalent

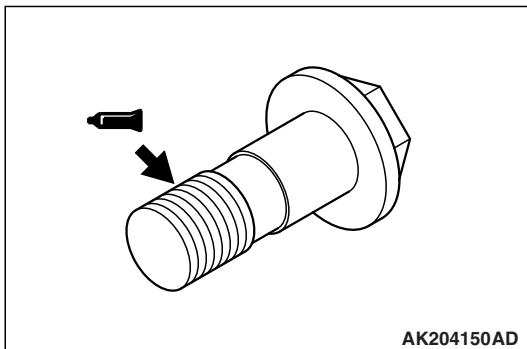

2. Tighten the bolts to the specified torque of 133 ± 4 N·m (98 ± 2 ft-lb) in the illustrated order.

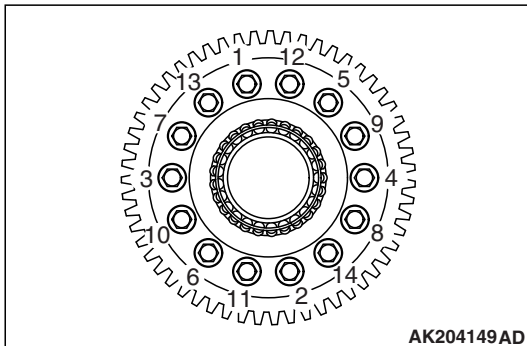

TRANSFER

DISASSEMBLY AND ASSEMBLY

M1222004000619

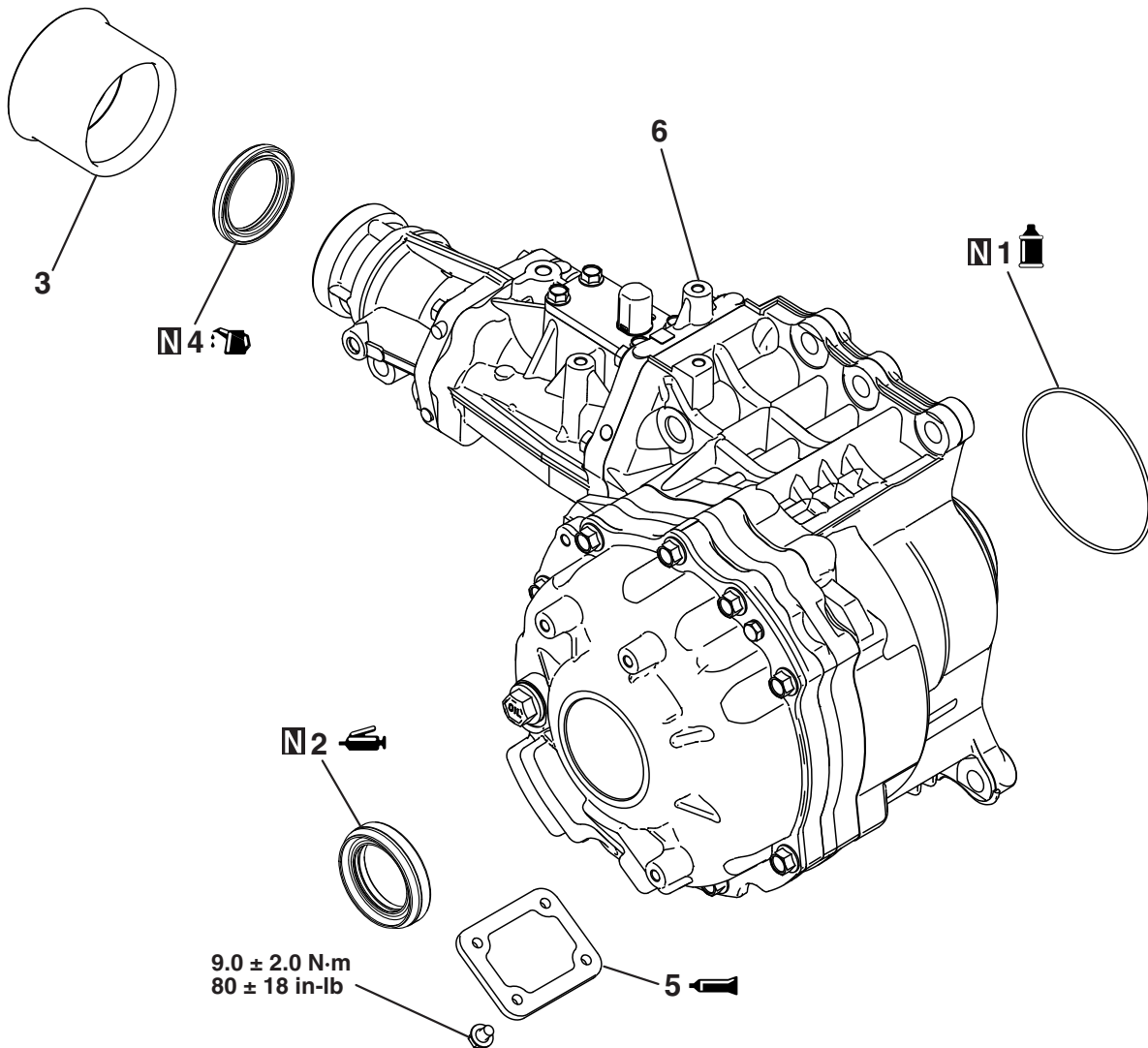

AK800089AF

- Removal steps**
- >>C<<
1. O-ring
 2. Oil seal
 3. Dust seal guard

- Removal steps (Continued)**
- >>B<<
>>A<<
4. Oil seal
 5. Cover
 6. Transfer

Required special tools:

- MD998382: Crankshaft front oil seal installer
- MD998550: Extension housing seal installer

ASSEMBLY SERVICE POINT

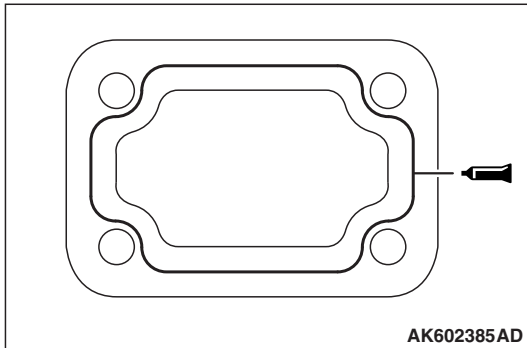

>>A<< COVER INSTALLATION

1. Completely degrease the FIPG-applied surface so that water and oil including the old sealant cannot adhere to the surface coated with the sealant.
Never touch the degreased surface by hand.
2. Apply a 1.5 mm (0.06 in) diameter bead of sealant as illustrated onto the cover.
Specified sealant: Mitsubishi Part No. MD997740 or equivalent
3. Attach the cover to the transfer and tighten it to the specified torque.

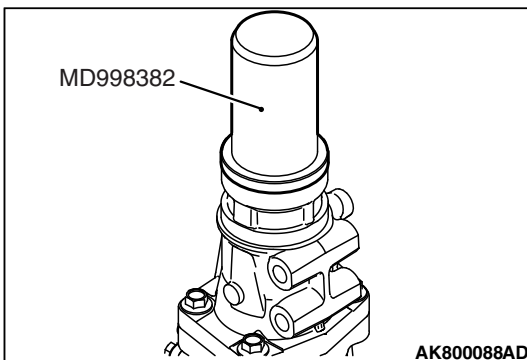

>>B<< OIL SEAL INSTALLATION

1. Using the special tool MD998382, to install the oil seal.
2. Apply transfer oil to the lip of oil seal.

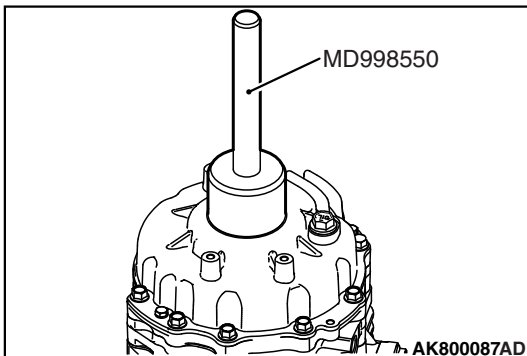

>>C<< OIL SEAL INSTALLATION

1. Using the special tool MD998550, to install the oil seal.
2. Apply specified grease to the oil seal lip area.
Specified grease: Retinax A